

Bovie®



IDS-210 Electrosurgical generator

Service Guide

Intro

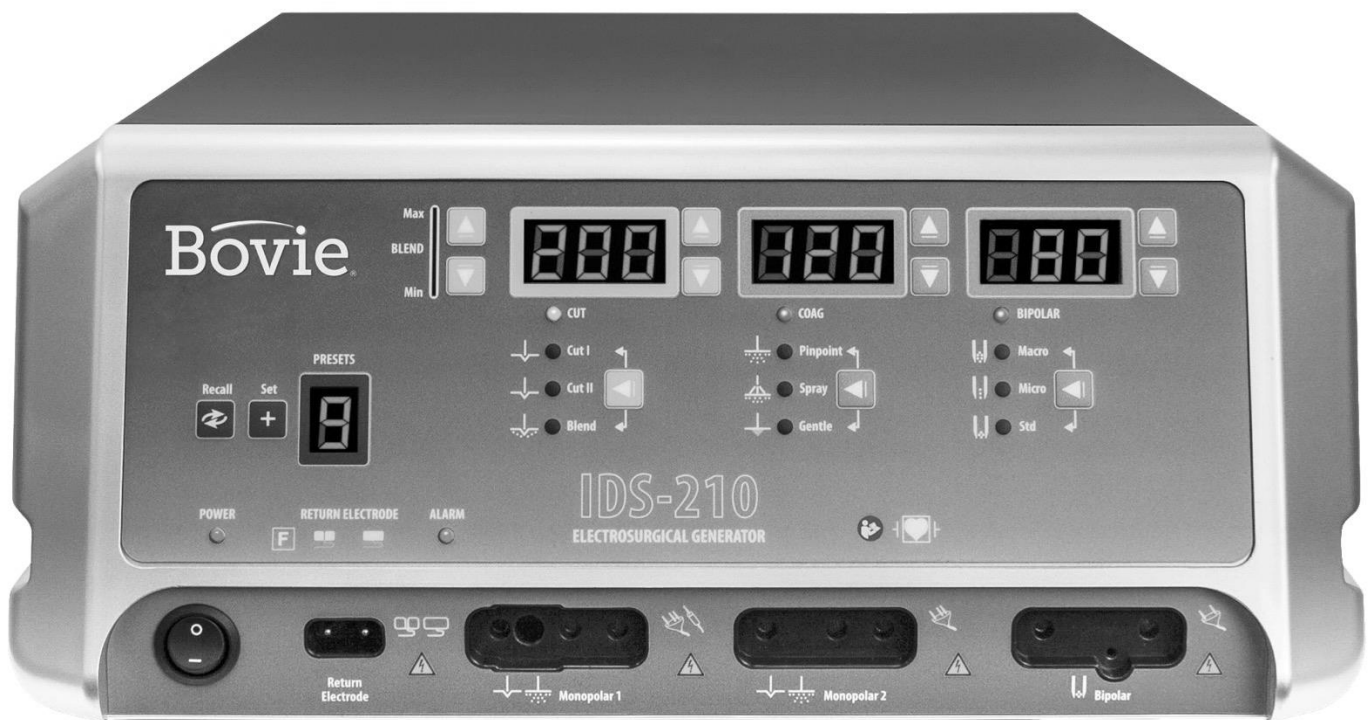

SERVICE GUIDE

This Service Guide and the equipment it describes are for qualified technicians who maintain and repair the Bovie® IDS-210 Electrosurgical Generator. Additional User information is available in the Bovie® IDS-210 User's Guide.

This document covers technical descriptions of the Bovie® IDS-210 including its physical appearance, all operator controls and indications, operational specifications, component functional descriptions (module level), diagrams of the electronic circuits used, and troubleshooting guidelines (with chart comparisons).

The Bovie® IDS-210 was constructed with the highest quality components. In the unlikely event that your generator fails within four years of purchase date, Aspen Surgical Products will warranty the product and effect factory repairs. Please refer to Appendix A, Warranty for what is covered, length of coverage, and "How to Receive a Return Authorization Number," in Section 8.

Equipment Covered in this Manual:

Bovie® IDS-210:

Reference No: IDS-210

For Information Contact



Aspen Surgical Products, Inc.

6945 Southbelt Dr. SE, Caledonia, MI 49316 USA

Phone: 616-698-7100 • Toll- Free: 888-364-7004

aspensurgical.com

Bovie Part Number - MC-55-231-002_5-EN

©2025 Aspen Surgical Products. All rights reserved. Contents of this publication may not be reproduced without the written permission of Aspen Surgical Products.

SAFETY PRECAUTIONS WHEN OPERATING THE GENERATOR

The safe and effective use of electrosurgery depends to a large degree on factors solely under the control of the operator. There is no substitute for a properly trained and vigilant medical staff. It is important that they read, understand, and follow the operating instructions supplied with this electrosurgical equipment.

To promote the safe use of the Bovie® IDS-210, please refer to the User's Guide for standard operating precautions.

APPLICABLE SAFETY STANDARDS

PART 1 ANSI/AAMI ES60601-1:2005 + C1:2009 + A2:2010 + A1:2012
CAN/CSA-C22.2 No. 60601-1:08 + C2:2011

PART 2 ANSI/AAMI 60601-2-2:2009 and CAN/CSA-C22.2 No. 60601-2-2:09

CONVENTIONS USED IN THIS GUIDE

WARNING:

Indicates a potentially hazardous situation which, if not avoided, could result in death or serious injury.

CAUTION:

Indicates a hazardous situation which, if not avoided, may result in minor or moderate injury.

NOTICE:

Indicates an operating tip, a maintenance suggestion, or a hazard that may result in product damage.

TABLE OF CONTENTS

SAFETY PRECAUTIONS WHEN OPERATING THE GENERATOR	iii
APPLICABLE SAFETY STANDARDS	iii
CONVENTIONS USED IN THIS GUIDE	iii
THE BOVIE® IDS-210	1
FUNCTIONAL DESCRIPTION	2
UNIT DESCRIPTION	4
SAFETY PRECAUTIONS WHEN REPAIRING THE GENERATOR	4
General Warnings, Cautions, and Notices	4
Active Accessories	5
Fire / Explosion Hazards	5
Generator Electric Shock Hazards	6
Servicing	6
Cleaning	6
CONTROLS, INDICATORS, AND RECEPTACLES	7
FRONT PANEL	8
Symbols on the Front Panel	8
Symbols on the Front Panel Continued	9
PRESET CONTROLS	10
MONOPOLAR POWER OUTPUT MODES	11
COAG CONTROLS	12
BIPOLAR POWER OUTPUT MODES	13
INDICATORS	14
POWER SWITCH AND RECEPTACLES	15
REAR PANEL	16
Symbols on the Rear Panel	16
TECHNICAL SPECIFICATIONS	18
PERFORMANCE CHARACTERISTICS	19
Input Power	19
Duty Cycle	19
Dimensions and Weight	19
Operating Parameters	19
Transport	19
Storage	19
Audio Volume	20
Return Electrode Sensing	20
High Frequency (RF) Leakage Current	21
STANDARDS AND IEC CLASSIFICATIONS	21
Class I Equipment (IEC 60601-1)	21

Type CF Equipment (IEC 60601-1) / Defibrillator Proof	21
Spill Resistance (IEC 60601-2-2)	21
Electromagnetic Interference	21
Electromagnetic Compatibility (IEC 60601-1-2 and IEC 60601-2-2)	21
Voltage Transients (Emergency Generator Mains Transfer)	21
OUTPUT CHARACTERISTICS	22
Maximum Output for Monopolar and Bipolar Modes	22
EMC COMPLIANCE	22
OUTPUT POWER CURVES	26
THEORY OF OPERATION	40
BLOCK DIAGRAM	41
FUNCTIONAL OVERVIEW OF KEY CIRCUITS	41
CONTROLS AND INDICATORS	41
FUNCTIONAL OVERVIEW OF MAIN BOARD	41
FUNCTIONAL OVERVIEW OF HIGH POWER CIRCUITS - MAIN BOARD	41
MAIN BOARD POWER FACTOR CORRECTOR	41
MAIN BOARD FULL BRIDGE SMPS	42
MAIN BOARD PUSH PULL POWER GENERATOR	42
HIGH VOLTAGE RELAYS AND MODE OUTPUT SELECT	42
LOW VOLTAGE FLYBACK SMPS AND VOLTAGE REGULATORS	42
SMPS DRIVER CIRCUIT	42
POWER GENERATOR DRIVER CIRCUIT	42
OPTOISOLATED RELAY CONTROL INTERFACE	42
AUDIO CONTROL CIRCUIT	42
AUXILIARY RELAY OUTPUT	43
HANDLE ACTIVATION AND FOOT-CONTROL RECOGNITION CIRCUITS	43
FOOTSWITCH ACTIVATION AND FOOT-SWITCH RECOGNITION CIRCUITS	43
NEM MONITORING CIRCUIT	43
TEMPERATURE SENSING CIRCUITS AND DC VOLTAGE MONITORING	43
FPGA CONTROL BLOCK	43
HIGH SPEED ANALOG-TO-DIGITAL CONVERTERS	43
1-WIRE INTERFACE BLOCK (OPTIONAL CIRCUIT)	43
MULTI-BUTTON HANDLE SUPPORT (OPTIONAL CIRCUIT)	44
VOLTAGE MAIN AND BACKUP SENSOR	44
CURRENT MAIN AND BACKUP SENSOR	44
CONTROLS AND INDICATORS	44
BOVIE® IDS-310 CONTROL SIGNAL INPUTS AND OUTPUTS	44
MAINTAINING THE BOVIE® IDS-210	54
CLEANING	55
PERIODIC INSPECTION	55
FUSE REPLACEMENT	55
FUSE REPLACEMENT ON THE MAIN PCB	56
Main PCB Fuse Information	56
OPERATING THE BOVIE® IDS-210	58
INSPECTING THE GENERATOR AND ACCESSORIES	59
SERVICE PERSONNEL SAFETY	59

INSTALLATION AND PLACEMENT.....	60
FUNCTIONAL (OPERATIONAL) CHECKS.....	60
Operating the Unit	60
Setting and Recalling Memory Presets.....	61
Activating the Unit	62
TROUBLESHOOTING.....	64
TECHNICAL VERIFICATION CHECKS.....	65
RECOMMENDED EQUIPMENT FOR TROUBLESHOOTING	66
TROUBLESHOOTING THE BOVIE® IDS-210.....	66
Inspecting the Generator	67
Inspecting the Receptacles.....	67
Inspecting Internal Components.....	68
SYSTEM FAULT CODE MESSAGES	69
SYSTEM FATAL ERROR MESSAGES.....	70
CORRECTING COMMON PROBLEMS	71
TEST POINTS.....	75
TEST POINTS – CONT.	76
TEST POINTS – CONT.	77
.....	78
REPAIR POLICY AND PROCEDURES.....	78
RESPONSIBILITY OF THE MANUFACTURER	79
RETURNING THE GENERATOR FOR SERVICE.....	79
Step 1 – Obtain a Returned Goods Authorization Number.....	79
Step 2 – Clean the Generator	79
Step 3 – Ship the Generator	79
WARRANTY	80
BOARD DRAWINGS, SCHEMATICS, & ASSEMBLIES.....	82
HOW TO ORDER PARTS FROM ASPEN SURGICAL PRODUCTS	83
BOVIE® IDS-210 DESIGN BREAKDOWN AND DRAWING REFERENCE	83
IDS-210 DRAWING AND SCHEMATIC PACKAGE.....	86
Schematic 1 Main Top	88
Schematic 2 Control.....	89
Schematic 3 Cyclone II FPGA Logic	90
Schematic 4 Logic PS Main	91
Schematic 5 Logic SMPS, AC/DC.....	92
Schematic 6 PFC Block	93
Schematic 7 Isolated Full Bridge SMPS.....	94
Schematic 8 Power Generator	95
Schematic 9 ETD49 Transformers.....	96

Schematic 10 Node Selection and Sensors.....	97
Schematic 11 Sensing A/D	98
Schematic 12 Output Relays.....	99
Schematic 13 Output Relays Decoder	100
Schematic 14 NEM Circuit	101
Schematic 15 Auto Bipolar Module.....	102
Schematic 16 Audio Control	103
Schematic 17 1-Wire Interface	104
Schematic 18 Test A/D.....	105
Schematic 19 Mounting Bosses and Holes.....	106
Schematic 20 Mono FSW & FOOTC Recognition	107
Schematic 21 Logic PS, Buck Regulator	108
Schematic 22 Relay Board Top	109
Schematic 23 Relay Board V-I-Sensors	110
Schematic 24 Display Board Page 1.....	111
Schematic 25 Display Board Page 2.....	112
Schematic 26 Connector Panel.....	113
Printed Circuit Board 1 Relay Board Top	114
Printed Circuit Board 2 Main Board.....	115
Printed Circuit Board 3 Display Board	116
Assembly Drawing 1 Back Plate Assembly.....	117
Assembly Drawing 2 Front Housing Assembly	118
Assembly Drawing 3 Final Assembly 1.....	119
Assembly Drawing 4 Final Assembly 2.....	120
Assembly Drawing 5 Final Assembly 3.....	121
Assembly Drawing 6 Final Assembly 4.....	122
Assembly Drawing 7 Final Assembly 5.....	123
Assembly Drawing 8 Final Assembly 6.....	124
Assembly Drawing 9 Final Assembly 7.....	125

LIST OF FIGURES

Figure 2 – 1 Layout of controls, indicators, and receptacles on the front panel.....	8
Figure 2 – 2 Layout of connectors and controls on the rear panel	16
Figure 3 – 1 Power setting versus maximum voltage (V _{peak}) CUT	26
Figure 3 – 2 Power setting versus maximum voltage (V _{peak}) COAG	26
Figure 3 – 3 Power setting versus maximum voltage (V _{peak}) BIPOLAR Macro, Micro and Standard	27
Figure 3 – 4 Output power all modes versus power setting at rated loads	27
Figure 3 – 5 Output power versus impedance for Cut I mode	28
Figure 3 – 6 Output power versus impedance for Cut II mode	28
Figure 3 – 7 Output power versus impedance for Blend (1, 2, 3, 4) mode	29
Figure 3 – 8 Output power vs impedance for Pinpoint mode	29
Figure 3– 9 Output power vs impedance for Spray mode	30
Figure 3 – 10 Output power vs impedance for Gentle Coagulation mode	30
Figure 3– 11 Output power vs impedance for Macro Bipolar mode.....	31
Figure 3– 12 Output power vs impedance for Micro Bipolar mode.....	31
Figure 3– 13 Output power vs impedance for Standard Bipolar mode	32
Figure 3– 14 Cut I Output Waveform (300 Ohm Load)	33
Figure 3– 15 Cut II Output Waveform (300 Ohm Load)	33
Figure 3– 16 Blend 1 Output Waveform (2000 Ohm Load).....	34
Figure 3– 17 Blend 2 Output Waveform (2000 Ohm Load).....	34
Figure 3– 18 Blend 3 Output Waveform (2000 Ohm Load).....	35
Figure 3– 19 Blend 4 Output Waveform (2000 Ohm Load).....	35
Figure 3– 20 Pinpoint Coagulation Output Waveform (2000 Ohm Load)	36
Figure 3– 21 Spray Coagulation Output Waveform (2000 Ohm Load).....	36
Figure 3– 22 Spray Coagulation Output Waveform (3000 Ohm Load).....	37
Figure 3– 23 Gentle Coagulation Output Waveform (100 Ohm Load	37
Figure 3– 24 Macro Bipolar Output Waveform (1000 Ohm Load)	38
Figure 3– 25 Micro Bipolar Output Waveform (800 Ohm Load)	38
Figure 3– 26 Standard Bipolar Output Waveform (200 Ohm Load)	39
Figure 4 – 1 Functional Block Diagram of the Bovie® IDS-210 system.	41
Figure 5 – 1 Fuse holder	55

THE BOVIE® IDS-210

This section includes the following information:

- Functional Description
- Unit Description
- Safety Precautions when Repairing the Generator

CAUTIONS:

Read all warnings, cautions, and instructions provided with this generator before using.

Read the instructions, warnings, and cautions provided with electro-surgical accessories before using. Specific instructions are not included in this manual.

Any serious incident that has occurred in relation to the device should be reported to Aspen Surgical Products, the governing body, and the Competent authority of the member state in which the incident occurred

FUNCTIONAL DESCRIPTION

The Bovie® IDS-210 Electrosurgical Generator is used to deliver RF energy via an assortment of surgical devices to cut and coagulate different kinds of tissue.

The Bovie® IDS-210 includes digital technology. This new technology is evident in the self-checking circuitry and error code readouts. The unit offers monopolar and bipolar electrosurgical operations.

The following are Bovie® IDS-210 key advantages and benefits:

- **Power capabilities**

- Up to 200 watts of pure cut in the Cut 1 mode @ 300 Ω
- Up to 200 watts of pure cut in the Cut II mode @ 300 Ω
- Up to 200 watts of Blend @ 300 Ω
- Up to 120 watts of Pinpoint/Spray Coagulation @ 500 Ω
- Up to 120 watts of Gentle Coagulation @ 125 Ω
- Up to 50-80 watts of Bipolar @ 50-100 Ω
- Up to 225 watts of Bovie® Bipolar @ 25 Ω

- **Two Cut Modes, Cut I & Cut II**

Two cut modes give the surgeon flexibility to cut all types of tissue without losing performance.

Cut I generates constant output power over a wide range of impedances. Refer to Appendix A, Technical Specifications section of this guide.

Cut II is a softer cut that generates constant output power with a lower voltage over a small range of impedances suggested for laparoscopic procedures. Refer to Appendix A, Technical Specifications section of this guide.

- **Four Levels of Blend**

The Blend mode is a combination of cutting and hemostasis. The Bovie® IDS-210 gives the surgeon freedom to adjust the desired level of hemostasis. A level setting of 1 is minimal blend with maximum cutting effect. A level setting of 4 is maximum hemostasis (blend) with minimal cutting effect. This adjustment is easily achieved by a incremental 4-level adjustment. Refer to Section 2, Controls, Indicators, and Receptacles, Cut and Blend Controls. The Blend mode improves the rate of targeted tissue desiccation without increasing the power delivered by the generator.

- **Three levels of coagulation: Pinpoint, Spray and Gentle Coagulation**

- Pinpoint provides precise control of bleeding in localized areas.
- Spray provides greater control of bleeding in highly vascular tissue over broad surface areas.
- The Gentle Coagulation Mode provides delicate coagulation.

- **Macro Bipolar Mode**

The Macro Bipolar Mode provides bipolar cutting or rapid coagulation. Power remains constant over a wide range of tissue types.

- **Micro Bipolar Mode**

The Micro Bipolar Mode provides precise Bipolar coagulation effects.

- **Standard Bipolar Mode**

The Standard Bipolar Mode provides power for conventional Bipolar output.

- **Presets**

The surgeon can store 10 user-defined RF presets and 6 interface Set-Up Preferences presets for easy recall of frequently used settings.

- **Return electrode sensing and contact quality monitoring**

The Bovie® IDS-210 incorporates a return electrode contact quality monitoring system (Bovie NEM™). This system detects the type of return electrode: solid or split. The system also continually monitors the contact quality between the patient and the split return electrode. This feature is designed to minimize patient burns at the return electrode site.

NOTICES:

The Bovie NEM™ system recommends that you use a split return electrode.

Before activation, pad placement and visual verification of the split return electrode (split pad) indicator on the front panel is recommended. After connecting the split pad to the generator and placing the split pad securely to the patient, give the unit 3 seconds to recognize the split pad. The split pad indicator will illuminate green. If the split pad and cord are attached to the generator without secure contact to the patient, the alarm indicator will illuminate red.

- **FDSTM (Fast Digital Feedback System)**

The FDSTM (Fast Digital Feedback System) measures voltage and current at 5,000 times a second and immediately adjusts the power to varying impedance during the electrosurgical procedure. The unit's digital technology senses and responds to changes in tissue density. Unlike analog, this feature reduces the need to adjust power settings manually with varying tissue impedance.

- **User-Friendly Design**

Digital interface with membrane switch feature selection.

- **Three Front Panel Accessory Connections and Two Rear Panel Footswitch Connections**

These connectors accept the latest monopolar and bipolar instruments. Refer to Section 2, Controls, Indicators, and Receptacles to learn more. Monopolar 1 connector accepts a standard 3-pin monopolar connector or adaptor (A1255A) for foot-controlled accessories. Monopolar 2 connector accepts a standard 3-pin monopolar connector for connecting standard monopolar accessories to the generator. The front panel also allows for a standard Bipolar accessory.

The rear panel monopolar footswitch connector accepts a Bovie® Monopolar Footswitch (BV-1253B). The rear panel bipolar footswitch connector accepts a Bovie® Bipolar Footswitch (BV-1254B).

- **Memory**

The unit automatically powers up to the last activated mode and power settings.

- **Isolated RF output**

This minimizes the potential of alternate site burns.

- **Self diagnostics**

These diagnostics continually monitor the unit to ensure proper performance.

UNIT DESCRIPTION

The Bovie® IDS-210 is a self-contained unit, consisting of the main enclosure and power cord. The main components incorporated in the generator include:

- Front Panel Components Power switch; membrane switches to control power output and mode selection; receptacles for connecting electrosurgical accessories; and indicators that show the current settings, patient return electrode status, and footswitch status.
- Rear Panel Components Volume control; bipolar and monopolar footswitch receptacles; power cable receptacle and fuse holder; equipotential grounding stud; and remote accessory receptacle.
- Internal Components Display board; main board; speaker board; relay board; power supply; and cables.

SAFETY PRECAUTIONS WHEN REPAIRING THE GENERATOR

Before servicing the Bovie® IDS-210, it is important that you read, understand, and follow the instructions supplied with the generator. Also, be familiar with any other equipment used to install, test, adjust, or repair the generator.

General Warnings, Cautions, and Notices

WARNINGS:

Use the generator only if the self-test has been completed as described. Otherwise, inaccurate power outputs may result.

CAUTIONS:

Do not stack equipment on top of the generator or place the generator on top of any electrical equipment. These configurations are unstable and/or do not allow adequate cooling.

Provide as much distance as possible between the electrosurgical generator and other electronic equipment (such as monitors). An activated electrosurgical generator may cause electrical interference with them.

Do not turn the activation tone down to an inaudible level. The activation tone alerts the surgical team when an accessory is active.

NOTICES:

If required by local codes, connect the generator to the hospital equalization (grounding) connector with an equipotential cable.

Connect the power cord to a wall receptacle having the correct voltage. Otherwise, product damage may result.

Electrosurgical equipment and accessories are intended to be used by health professional educated in their use.

Active Accessories

WARNINGS:

Shock Hazard - Do not connect wet accessories to the generator.

Shock Hazard - Ensure that all accessories and adapters are correctly connected and that no metal is exposed.

CAUTIONS:

Accessories must be connected to the proper receptacle type. In particular, bipolar accessories must be connected to the Bipolar Instrument receptacle only. Improper connection may result in inadvertent generator activation.

Set power levels to the lowest setting before testing an accessory.

Reusable devices are provided non-sterile and must be processed prior to use to include first use. Processing is defined on specific Instructions provided with each device.

Single Use Devices Only: Reusing or reprocessing single use devices may cause damage to the device which in turn may cause unnecessary harm to the user and/or patient. Reuse or reprocessing is not recommended.

After Use or upon determining product can no longer be used due to wear or damage, safely discard in accordance with established procedures for biohazardous waste.

Notice: For applicable IFU/additional information: Visit <https://www.aspensurgical.com/Resources/Documents/IFUs>

Please refer to the manufacturer of the generator for warnings, precautions, contra-indications, undesirable side-effect, measures to be taken, and limitations of use for the electrosurgical system and accessories.

NOTICE:

During bipolar electrosurgery, do not activate the generator until the forceps have made contact with the patient. Product damage may occur.

Fire / Explosion Hazards

WARNINGS:

Explosion Hazard – Do not install the generator in the presence of flammable anesthetics, gases, liquids, or objects.

Fire Hazard – Do not place active accessories near or in contact with flammable materials (such as gauze or surgical drapes). Electrosurgical accessories that are activated or hot from use can cause a fire. Use a holster to hold electrosurgical accessories safely away from personnel and flammable materials.

Fire Hazard – Do not use extension cords.

Fire Hazard – For continued protection against fire hazard, replace fuses only with fuses of the same type and rating as the original fuse.

Warning: Due to concerns about the carcinogenic and infectious potential of electrosurgical byproducts (such as tissue smoke plume and aerosols which may include toxic gasses and vapors, live and dead cellular material, and viruses), protective eyewear, filtration masks, and effective smoke evacuation equipment should be used in both open and laparoscopic procedures. Contact Aspen Surgical Products at customerservice@aspensurgical.com for additional information or to inquire about our smoke evacuation solutions.

Generator Electric Shock Hazards

WARNINGS:

Connect the generator power cord to a properly grounded receptacle. Do not use power plug adapters.

Do not connect a wet power cord to the generator or to the wall receptacle.

To allow stored energy to dissipate after power is disconnected (caps discharge), wait at least five minutes before replacing parts.

Always turn off and unplug the generator before cleaning.

Do not touch any exposed wiring or conductive surfaces while the generator is disassembled and energized. Never wear a grounding strap when working on an energized generator.

When taking troubleshooting measurements use appropriate precautions such as using isolated tools and equipment, using the "one hand rule," etc.

Potentially lethal AC and DC voltages are present in the AC line circuitry, high voltage DC circuitry, and associated mounting and heat sink hardware described in this manual. These potentials are not isolated from the AC line. Take appropriate precautions when testing and troubleshooting this area of the generator.

High frequency, high voltage signals that can cause severe burns are present in the RF output stage and in the associated mounting and heat sink hardware. Take appropriate precautions when testing and troubleshooting this area of the generator.

Residual Risks and Adverse Reactions/Adverse effects associated with the use of this device may include thermal damage, shock, or electrocution, burns, fire, biohazard (from smoke). Additionally, accessories include risks associated with patient contact including unintended cut, allergic reaction, and infection.

Servicing

CAUTIONS:

Read all warnings, cautions, and instructions provided with this generator before servicing.

The generator contains electrostatic-sensitive components. When repairing the generator, work at a static-control workstation. Wear a grounding strap when handling electrostatic-sensitive components, except when working on an energized generator. Handle circuit boards by their nonconductive edges. Use an anti-static container for transport of electrostatic-sensitive components and circuit boards.

Cleaning

NOTICE:

Do not clean the generator with abrasive cleaning or disinfectant compounds, solvents, or other materials that could scratch the panels or damage the generator.

CONTROLS, INDICATORS, AND RECEPTACLES

This section describes:

- The Front and Rear Panels
- Controls, Indicators, Receptacles, and Ports

FRONT PANEL

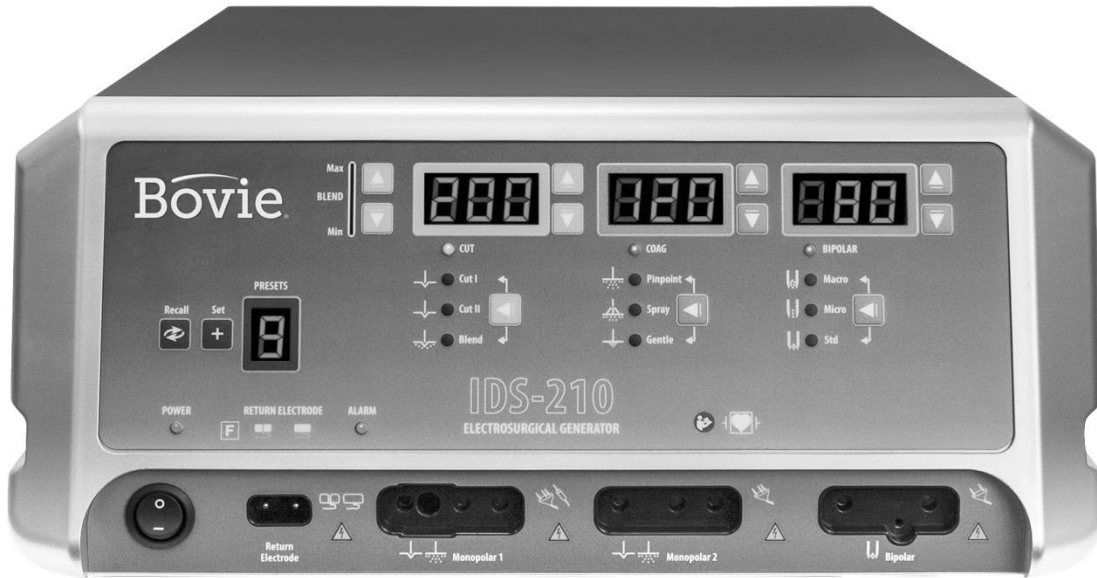









Figure 2 – 1 Layout of controls, indicators, and receptacles on the front panel

















Symbols on the Front Panel

Refer to the following table for descriptions of symbols found on the front panel of the Bovie® IDS-210.

SYMBOLS	DESCRIPTION
<p><i>Cut Controls</i></p>  <p>Cut mode (Cut I and Cut II)</p>  <p>Blend mode</p>	
<p><i>Coag Controls</i></p>  <p>Pinpoint Mode</p>  <p>Spray Mode</p>  <p>Gentle Mode</p>	
<p><i>Bipolar Controls</i></p>  <p>Macro Bipolar Mode</p>  <p>Micro Bipolar Mode</p>  <p>Standard Bipolar Mode</p>	

Symbols on the Front Panel Continued

Refer to the following table for descriptions of symbols found on the front panel of the Bovie® IDS-210.

SYMBOLS	DESCRIPTION
<i>Selection</i>	
	Select / Toggle / Adjust Settings
	Recall
	Set
<i>Indicators</i>	
	Split Return Electrode
	Solid Return Electrode
<i>Regulatory Symbolology</i>	
	Mandatory: Refer to instruction manual / guide
	Defibrillator Proof Type CF Equipment
	RF Isolated – patient connections are isolated from earth at high frequency.
	Warning: Dangerous voltage
<i>Power Switch and Receptacles</i>	
	Power OFF
	Power ON
	Return Electrode (Split)
	Return Electrode (Solid)
	Monopolar Handpiece 1 - (for 3-pin monopolar connection)
	Monopolar Handpiece 1 - (for single plug monopolar connection)
	Monopolar Handpiece 2
	Bipolar Handpiece

PRESET CONTROLS

Preset / SetUp Display

Preset indicates the current selection of one of the 10 RF presets (0-9). Also indicates a dash “-” when a Preset is not selected.

Recall Button

Toggles through the 10 RF presets.



Set Button

Sets the desired preset into one of the 10 user-defined presets. Press and hold the Set button for three seconds to save the settings.

Preset Indicator LED

Blinks in the lower right corner of the Preset display to indicate that the current setting is not one of the user-defined presets.

NOTICES:

The Bovie, IDS-210 incorporates 10 RF presets that are factory set to zero watts and can be programmed to your preferred settings.

Set and Recall are disabled while the unit is activated.

MONOPOLAR POWER OUTPUT MODES

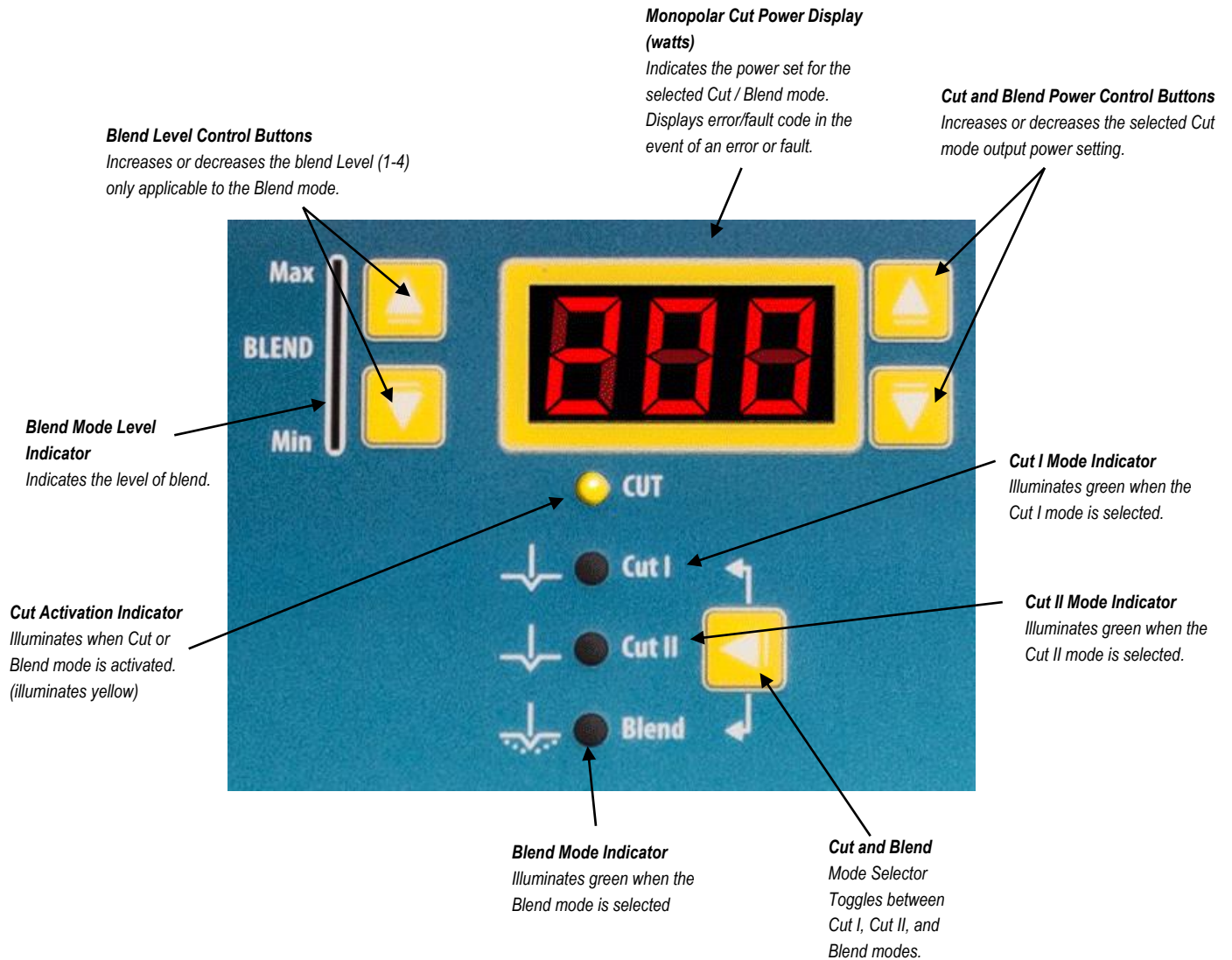

COAG CONTROLS

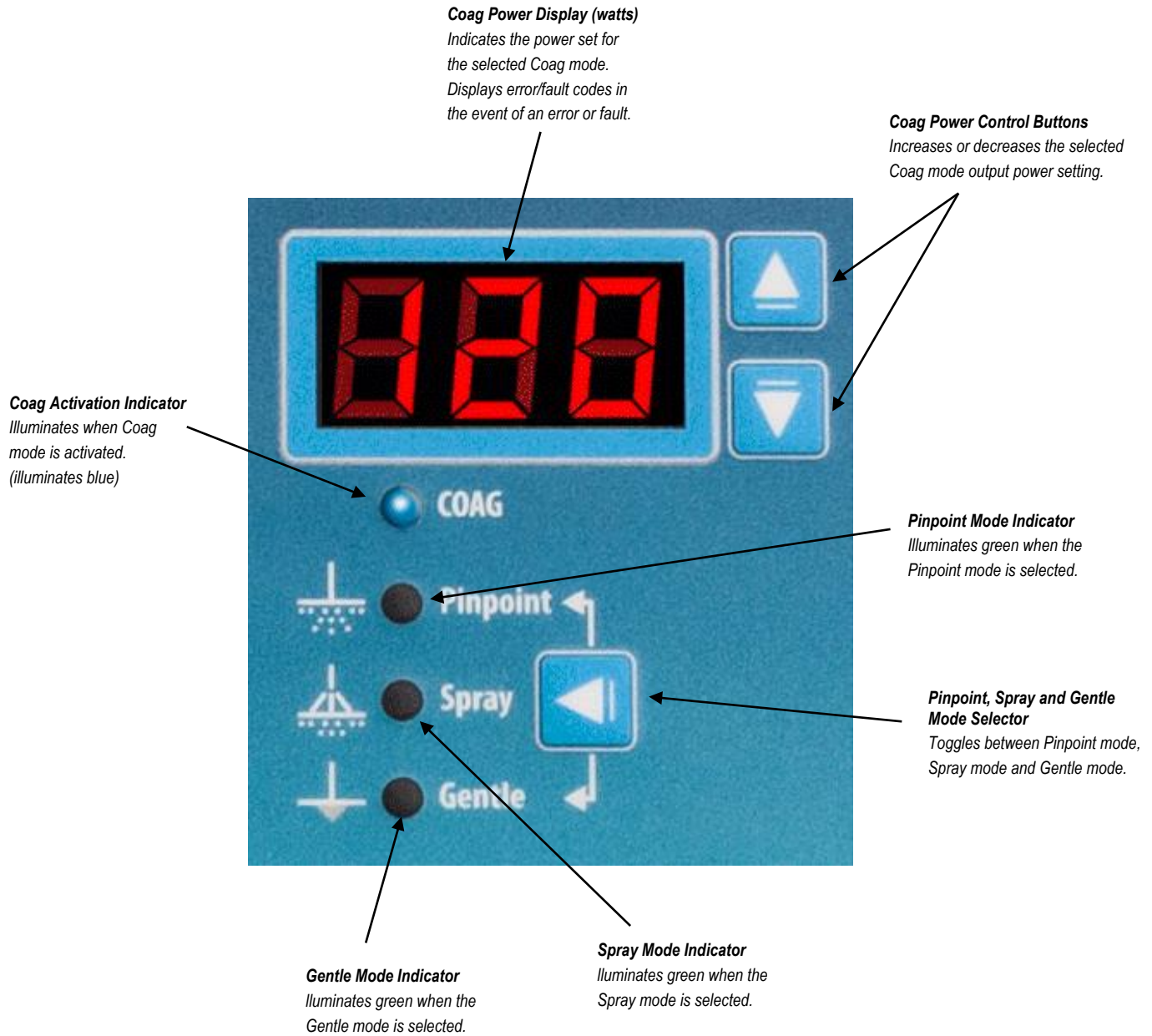

BIPOLAR POWER OUTPUT MODES

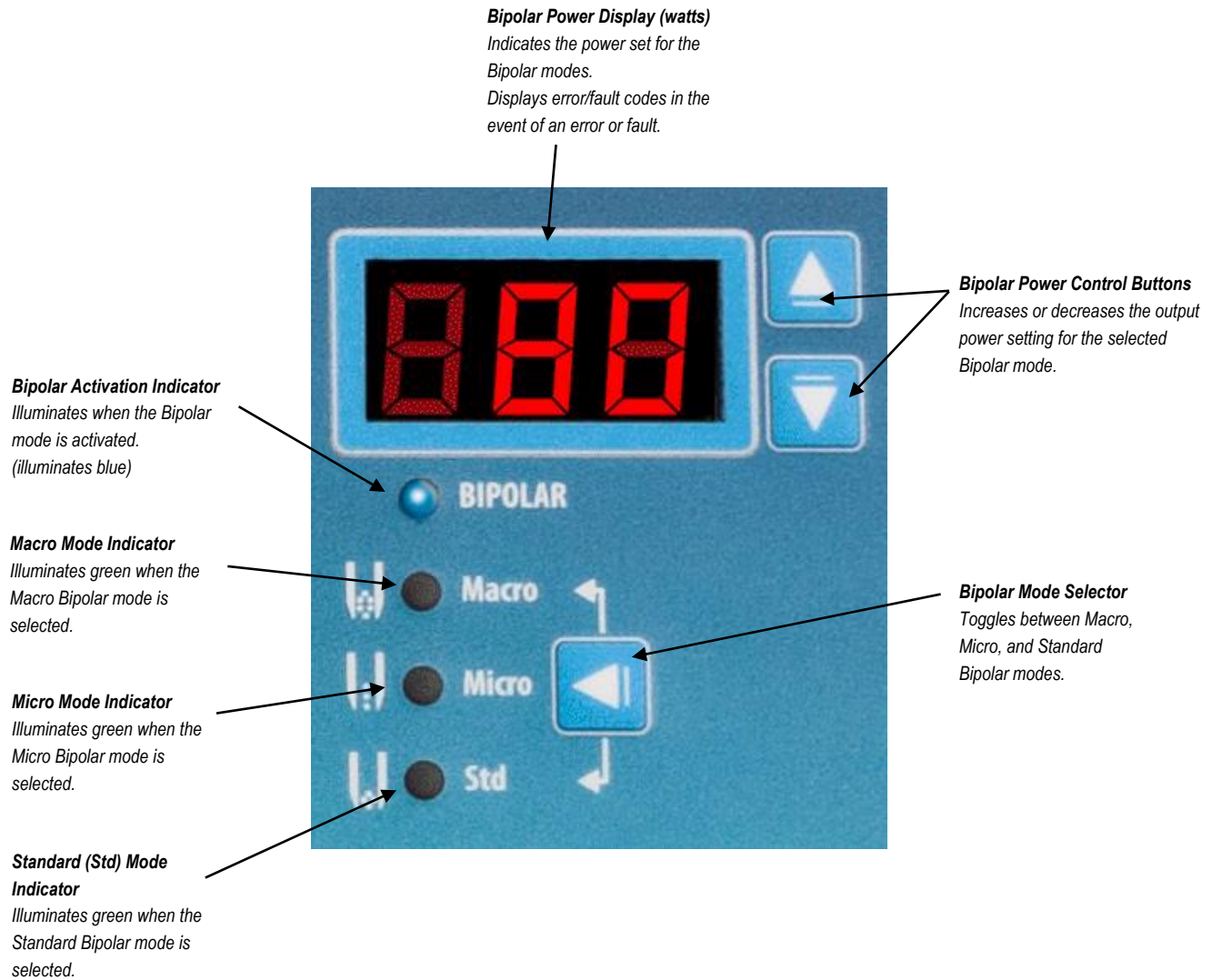

INDICATORS

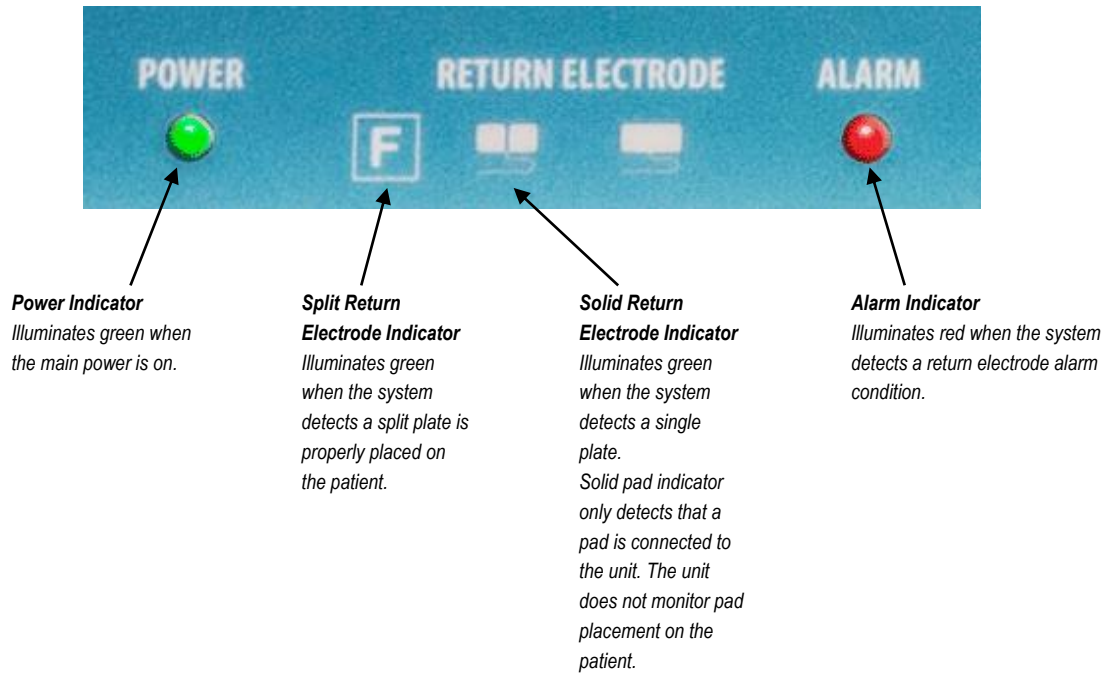

POWER SWITCH AND RECEPTACLES

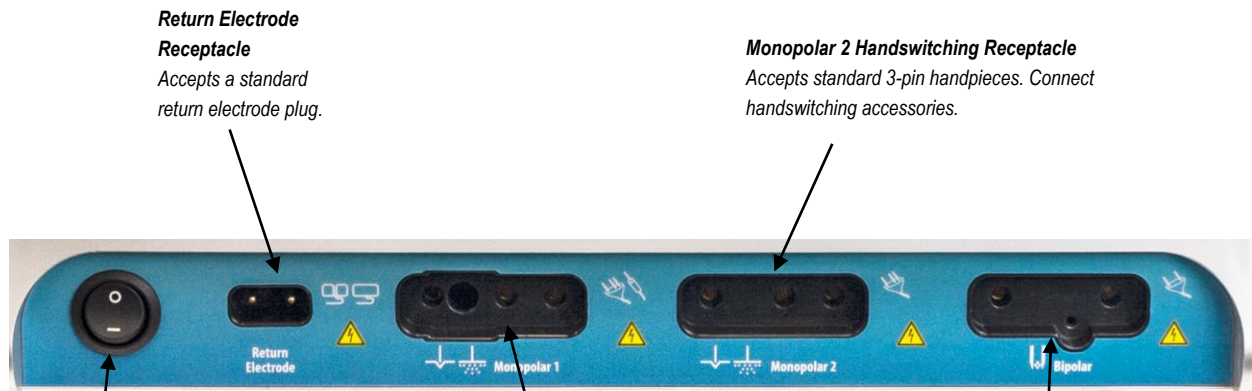

Return Electrode Receptacle
Accepts a standard return electrode plug.

Monopolar 2 Handswitching Receptacle
Accepts standard 3-pin handpieces. Connect handswitching accessories.

Power On/Off Switch
Turns the unit on or off.

Monopolar 1 Handswitching/ Footswitching Receptacle
Monopolar 1 connector accepts a standard 3-pin monopolar connector or adaptor (A1255A) for foot-controlled accessories.

Bipolar Receptacle
Accepts standard cables for bipolar handpieces. Connect bipolar accessories.

REAR PANEL

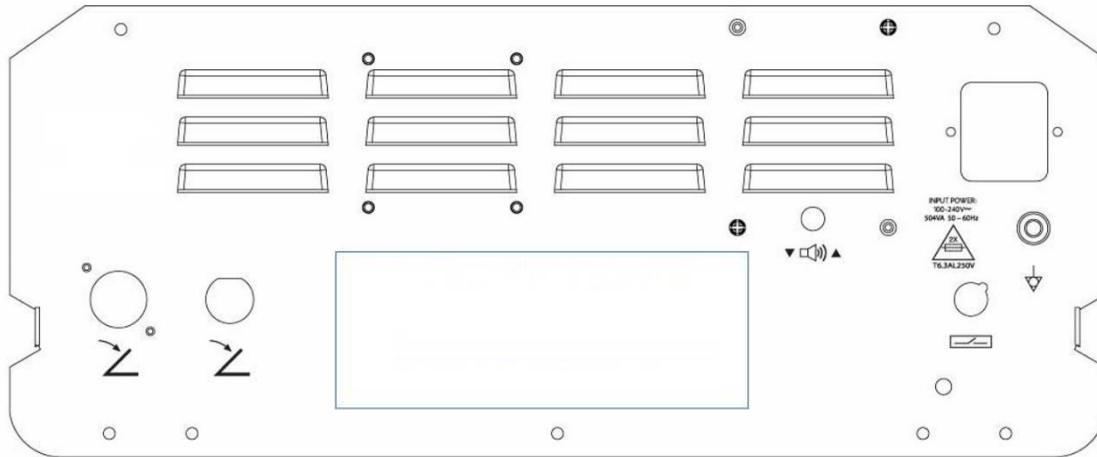

Figure 2 – 2 Layout of connectors and controls on the rear panel

Symbols on the Rear Panel

Refer to the following table for descriptions of symbols found on the rear panel of the Bovie® IDS-210.

SYMBOLS	DESCRIPTION
	Equipotential Ground Stud
	Medical Device
	Unique Device Identifier
	Reference Number
	Serial Number
	Caution
	Volume Control
	Fuse Enclosed
	Relay Connector
	Monopolar Footswitch Input Jack (Far left)
	Bipolar Footswitch Input Jack
	Manufacturer
	Caution, Consult Accompanying Documents
	Do Not Dispose of Unit in Municipal Waste Stream.

NOTICE:

Please note that infected medical devices must be disposed of as medical/biohazard waste and cannot be included in used electronic equipment disposal/recycling programs. In addition, certain electronic products must be returned directly to Aspen Surgical Products. Contact your Bovie® sales representative for return instructions.

TECHNICAL SPECIFICATIONS

All specifications are nominal and subject to change without notice. A specification referred to as “typical” is within $\pm 20\%$ of a stated value at room temperature (25° C / 77° F) and a nominal input power voltage.

PERFORMANCE CHARACTERISTICS

Input Power

Input Voltage	100-240V~ ± 10%
Mains line frequency range (nominal):	50 – 60 Hz
Power consumption:	504 VA
Fuses (two):	6.3 A (slow blow)

Duty Cycle

Under maximum power settings and rated load conditions (Cut I, 200 watt @ 300 ohm load), the generator is suitable for activation times of 10 seconds ON followed by 30 seconds OFF for 30 minutes.

The internal temperature of the unit is continuously monitored. If the temperature rises above 75° C, the alert will sound and output power will be deactivated.

Dimensions and Weight

Width	37.5 cm (14.75 in.)	Depth	46 cm (18.1 in.)
Height	16.5 cm (6.5 in.)	Weight	< 9.07 kg (< 20 lbs)

Operating Parameters

Ambient temperature range	10° to 40° C
Relative humidity	30% to 75%, non-condensing
Atmospheric pressure	70kPa to 106kPa
Warm-up time	If transported or stored at temperatures outside the operating temperature range, allow one hour for the generator to reach room temperature before use.

Transport

Ambient temperature range	-40° to +70° C
Relative humidity	10% to 100%, including condensation
Atmospheric pressure	50kPa to 106kPa

Storage.

Ambient temperature range	10° to 30° C
Relative humidity	10% to 75%, non-condensing
Atmospheric pressure	50kPa to 106kPa

The device should be stored and used in a room temperature of approximately 77° F/25° C

Audio Volume

The audio levels stated below are for activation tones (cut, coag, and bipolar) and alert tones (return electrode and system alerts) at a distance of one meter. Alert tones meet the requirements for IEC 60601-2-2.

Activation Tone

Volume (adjustable)	≥ 40 dBA
Frequency	All Cut Modes: 610 Hz ± 25 Hz All Coagulation Modes: 910 Hz ± 25 Hz Simultaneous Spray Mode: 1667 Hz ± 50 Hz All Bipolar Modes: 910 Hz ± 25 Hz
Duration	Continuous while the generator is activated

Alert Tone

Volume (not adjustable)	> 65 dBA
--------------------------------	----------

Fault Tone

Volume (not adjustable)	> 65 dBA
Audio Fault Tone	2.4 kHz 450 milliseconds / 1.2 kHz 450 milliseconds

Return Electrode Sensing

The system presents audible and visible alerts when it senses no return electrode.

Solid	Trip resistance: 0 Ω to 8 Ω ± 1 Ω Continuous measurement: Once the system establishes the solid return electrode resistance, an increase to 20 Ω - 25 Ω in resistance will cause an alert. When the alert condition exists, the system deactivates output power.
Split	Trip resistance: 10 Ω ± 5 Ω to 135 Ω ± 10 Ω Continuous measurement: Once the system establishes the split return electrode resistance, an increase of 40% in resistance will cause an alert. When the alert condition exists, the system deactivates output power.

High Frequency (RF) Leakage Current

Bipolar Micro, Macro leakage current	< 63 mA _{rms}
Bipolar Standard leakage current	< 50 mA _{rms}
Monopolar RF leakage current	< 150 mA _{rms}

Operating Conditions

RF energy is generated and passed through an interconnecting cable to an accessory where the energy is delivered to cut, coagulate and ablate tissue.

STANDARDS AND IEC CLASSIFICATIONS

Class I Equipment (IEC 60601-1)

Equipment protection against electric shock by (Earthed) additional protection to basic insulation through means of connecting exposed conductive parts to the protective Earth in the fixed wiring of the installation.

Type CF Equipment (IEC 60601-1) / Defibrillator Proof



The Bovie® IDS-210™ provides a high degree of protection against electric shock, particularly regarding allowable leakage currents. It is type CF equipment. Patient connections are isolated from earth and resist the effects of defibrillator discharge.

Spill Resistance (IEC 60601-2-2)

The generator enclosure is constructed so that liquid spillage in normal use does not wet electrical insulation or other components which, when wet, are likely to affect adversely the safety of the generator.

Electromagnetic Interference

When other equipment is placed on or beneath a Bovie® IDS-210, the unit can be activated without interference. The generator minimizes electromagnetic interference to video equipment used in the operating room.

Electromagnetic Compatibility (IEC 60601-1-2 and IEC 60601-2-2)

The Bovie® IDS-210 complies with the appropriate IEC 60601-1-2 and IEC 60601-2-2 specifications regarding electromagnetic compatibility.

Voltage Transients (Emergency Generator Mains Transfer)

The Bovie® IDS-210 operates in a safe manner when the transfer is made between line AC and an emergency generator voltage source.

OUTPUT CHARACTERISTICS

Maximum Output for Monopolar and Bipolar Modes

Power readouts agree with actual power into rated load to within 20% or 5 watts, whichever is greater.

Mode	Max Power	Rated Load	Output Frequency	Repetition Rate	Duty Cycle	Vpeak Max	Crest Factor* (Rated Load)
Cut I	200 W	300 Ω	490 kHz ± 4.9 kHz	N/A	N/A	1000V	1.7 ± 20%
Cut II	200 W	300 Ω	490 kHz ± 4.9 kHz	N/A	N/A	750V	1.7 ± 20%
Blend (1)	200 W	300 Ω	490 kHz ± 4.9 kHz	30 kHz ± 5 kHz	75% duty cycle	1320V	1.8 ± 20%
Blend (2)	200 W	300 Ω	490 kHz ± 4.9 kHz	30 kHz ± 5 kHz	62.5% duty cycle	1475V	2.0 ± 20%
Blend (3)	200 W	300 Ω	490 kHz ± 4.9 kHz	30 kHz ± 5 kHz	50% duty cycle	1650V	2.2 ± 20%
Blend (4)	200 W	300 Ω	490 kHz ± 4.9 kHz	30 kHz ± 5 kHz	37.5% duty cycle	1870V	2.4 ± 20%
Pinpoint Coag	120 W	500 Ω	490 kHz ± 4.9 kHz	30 kHz ± 5 kHz	25% duty cycle	1800V	3.1 ± 20%
Spray Coag	120 W	500 Ω	350 to 450 kHz	20 to 45 kHz	5.9 to 14.2% duty cycle	4000V	6.0 ± 20%
Gentle Coag	120 W	125 Ω	490 kHz ± 4.9 kHz	N/A	N/A	450V	1.6 ± 20%
Macro Bipolar	80 W	100 Ω	490 kHz ± 4.9 kHz	N/A	N/A	600V	1.5 ± 20%
Micro Bipolar	80 W	100 Ω	490 kHz ± 4.9 kHz	N/A	N/A	500V	1.5 ± 20%
Standard Bipolar	80 W	50 Ω	490 kHz ± 4.9 kHz	N/A	N/A	250V	1.5 ± 20%

- an indication of a waveform's ability to coagulate bleeders without a cutting effect.

EMC COMPLIANCE

Special precautions should be taken regarding the Bovie® IDS-210. Medical Electrical Equipment needs special precautions regarding EMC and needs to be installed and put into service according to the EMC information provided in this manual.

Understand that only the Accessories supplied with or ordered from Bovie® should be used with your device. The use of accessories, transducers, and cables other than those specified, may result in increased Emissions or decreased Immunity of the Bovie® IDS-210. The Bovie® IDS-210 and its accessories are not suitable for interconnection with other equipment.

Portable and mobile RF communications equipment can affect Medical Electrical Equipment. The Bovie® IDS-210 should not be used adjacent to or stacked with other equipment and that if adjacent or stacked use is necessary, the Bovie® IDS-210 should be observed to verify normal operation in the configuration in which it will be used.

Recommended separation distances between portable and mobile RF communications equipment and the Bovie® IDS-210			
The Bovie® IDS-210 is intended for use in an electromagnetic environment in which radiated RF disturbances are controlled. The customer or the user of the Bovie® IDS-210 can help prevent electromagnetic interference by maintaining a minimum distance between portable and mobile RF communications equipment (transmitters) and the Bovie® IDS-210 as recommended below, according to the maximum output power of the communications equipment.			
Rated maximum output power of transmitter W	separation distance according to frequency of transmitter		
	150 kHz to 80 MHz $d = \left[\frac{3.5}{V_1} \right] \sqrt{P}$	80 MHz to 800 MHz $d = \left[\frac{3.5}{E_1} \right] \sqrt{P}$	800 MHz to 2.5 GHz $d = \left[\frac{7}{E_1} \right] \sqrt{P}$
0.01	0.12	0.12	0.23
0.1	0.38	0.38	0.73
1	1.2	1.2	2.3
10	3.8	3.8	7.3
100	12	12	23
For transmitters rated at a maximum output power not listed above, the recommended separation distance d in metres (m) can be estimated using the equation applicable to the frequency of the transmitter, where P is the maximum output power rating of the transmitter in watts (W) according to the transmitter manufacturer. NOTE 1 At 80 MHz and 800 MHz, the separation distance for the higher frequency range applies. NOTE 2 These guidelines may not apply in all situations. Electromagnetic propagation is affected by absorption and reflection from structures, objects and people.			

Guidance and manufacturer's declaration – electromagnetic emissions		
The Bovie® IDS-210 is intended for use in the electromagnetic environment listed below. The customer or the user of the Bovie® IDS-210 should assure that is used in such an environment.		
Emissions test	Compliance	Electromagnetic environment – guidance
RF Emissions CISPR 11	Group 1	The Bovie® IDS-210 must emit electromagnetic energy in order to perform its intended function. Nearby electronic equipment may be affected.
RF Emissions CISPR 11	Class A	The Bovie® IDS-210 is suitable for use in all establishments other than domestic and those directly connected to the public low-voltage power supply network that supplies buildings used in domestic purposes.
Harmonic emissions IEC 61000-3-2	Class A	
Voltage fluctuations/flicker Emissions IEC 61000-3-3	Complies	

Guidance and manufacturer's declaration – electromagnetic immunity

The Bovie® IDS-210 is intended for use in the electromagnetic environment listed below.
The customer or the user of the Bovie® IDS-210 should assure that it is used in such an environment.

Immunity test	IEC 60601 test level	Compliance level	Electromagnetic environment – guidance
Electrostatic discharge (ESD) IEC 61000-4-2	±6 kV contact ±8 kV air	±6 kV contact ±8 kV air	Floors should be wood, concrete or ceramic tile. If floors are covered with synthetic material, the relative humidity should be at least 30%.
Electrical fast transient/burst IEC 61000-4-4	±2 kV for power supply lines ±1 kV for input/output lines	±2 kV for power supply lines ±1 kV for input/output lines	Mains power quality should be that of a typical commercial or hospital environment.
Surge IEC 61000-4-5	±1 kV differential mode ±2 kV common mode	±1 kV differential mode ±2 kV common	Mains power quality should be that of a typical commercial or hospital environment.
Voltage dips, short interruptions and voltage variations on power supply input lines IEC 61000-4-11	<5 % U_t (<95 % dip in U_t) for 0.5 cycle <40 % U_t (<60 % dip in U_t) for 5 cycles 70 % U_t (<30 % dip in U_t) for 25 cycles <5 % U_t (>95 % dip in U_t) for 5 sec	<5 % U_t (<95 % dip in U_t) for 0.5 cycle <40 % U_t (<60 % dip in U_t) for 5 cycles 70 % U_t (<30 % dip in U_t) for 25 cycles <5 % U_t (>95 % dip in U_t) for 5 sec	Mains power quality should be that of a typical commercial or hospital environment. If the user of the Bovie® IDS-210 requires continued operation during power mains interruptions, it is recommended that the Bovie® IDS-210 be powered from an uninterruptible power supply or a battery.
Power frequency (50/60 Hz) magnetic field IEC 61000-4-8	3 A/m	3 A/m	Power frequency magnetic fields should be at levels characteristic of a typical location in a typical commercial or hospital environment.

NOTE U_t is the a.c. mains voltage prior to application of the test level.

Guidance and manufacturer's declaration – electromagnetic immunity continued...

Immunity test	IEC 60601 test level	Compliance level	Electromagnetic environment – guidance
Conducted RF IEC 61000-4-6	3 Vrms 150 kHz to 80 MHz	3 Vrms	Portable and mobile RF communications equipment should be used no closer to any part of the Bovie® IDS-210, including cables, than the recommended separation distance calculated from the equation applicable to the frequency of the transmitter. Recommended separation distance $d = \left[\frac{3.5}{V_1} \right] \sqrt{P}$
Radiated RF IEC 61000-4-3	3 V/m 80 MHz to 2.5 GHz	3 V/m	$d = \left[\frac{3.5}{E_1} \right] \sqrt{P}$ 80 MHz to 800 MHz $d = \left[\frac{7}{E_1} \right] \sqrt{P}$ 800 MHz to 2.5 GHz where P is the maximum output power rating of the transmitter in watts (W) according to the transmitter manufacturer and d is the recommended separation distance in metres (m) Field strengths from fixed RF transmitters, as determined by an electromagnetic site survey, should be less than the compliance level in each frequency range. ^b Interference may occur in the vicinity of equipment marked with the following symbol. 
NOTE 1 At 80 MHz and 800 MHz, the separation distance for the higher frequency range applies. NOTE 2 These guidelines may not apply in all situations. Electromagnetic propagation is affected by absorption and reflection from structures, objects and people.			
^a Field strength from fixed transmitters, such as base stations for radio (cellular/cordless) telephones and land mobile radios, amateur radio, AM and FM radio broadcast and TV broadcast cannot be predicated theoretically with accuracy. To assess the electromagnetic environment due to fixed RF transmitters, an electromagnetic site survey should be considered. If the measured field strength in the location which the Bovie® IDS-210 is used exceeds the applicable RF compliance level above, the Bovie® IDS-210 should be observed to verify normal operation. If abnormal performance is observed, additional measures may be necessary, such as reorienting or relocating the Bovie® IDS-210. ^b Over the frequency range 150 kHz to 80 MHz, field strengths should be less than $[V_1]$ V/m.			

OUTPUT POWER CURVES

Figures 3–1 through 3–3 illustrate power setting versus maximum voltage (V_{peak}). Figure 3–4 illustrates output power versus power setting for all modes. Figures 3–5 through 3–13 illustrate specific output power delivered to a range of load resistances for each mode.

Figure 3–1 Power setting versus maximum voltage (V_{peak}) CUT

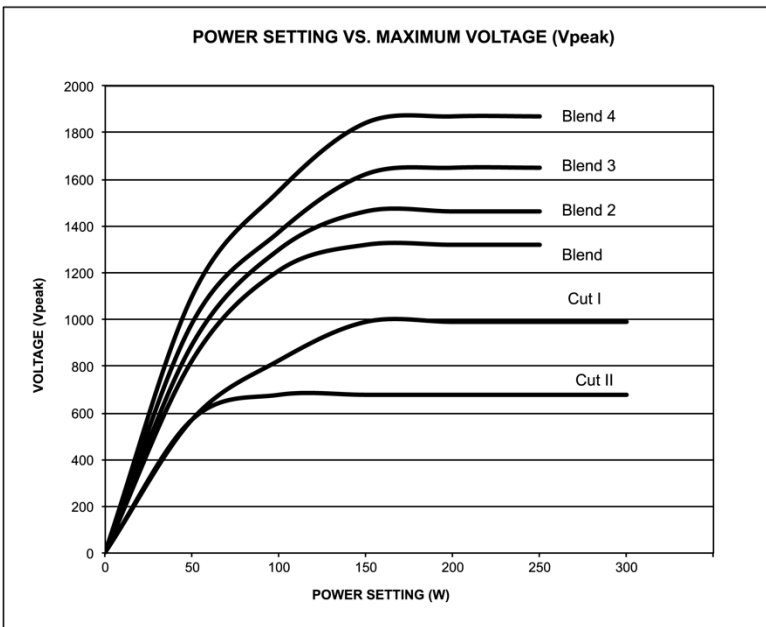

Figure 3–2 Power setting versus maximum voltage (V_{peak}) COAG

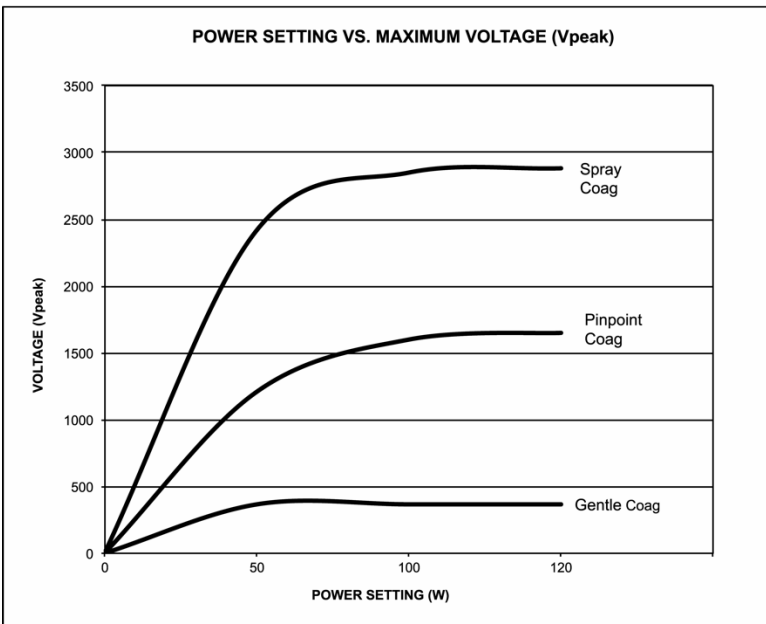

Figure 3 – 3 Power setting versus maximum voltage (Vpeak) BIPOLAR Macro, Micro and Standard

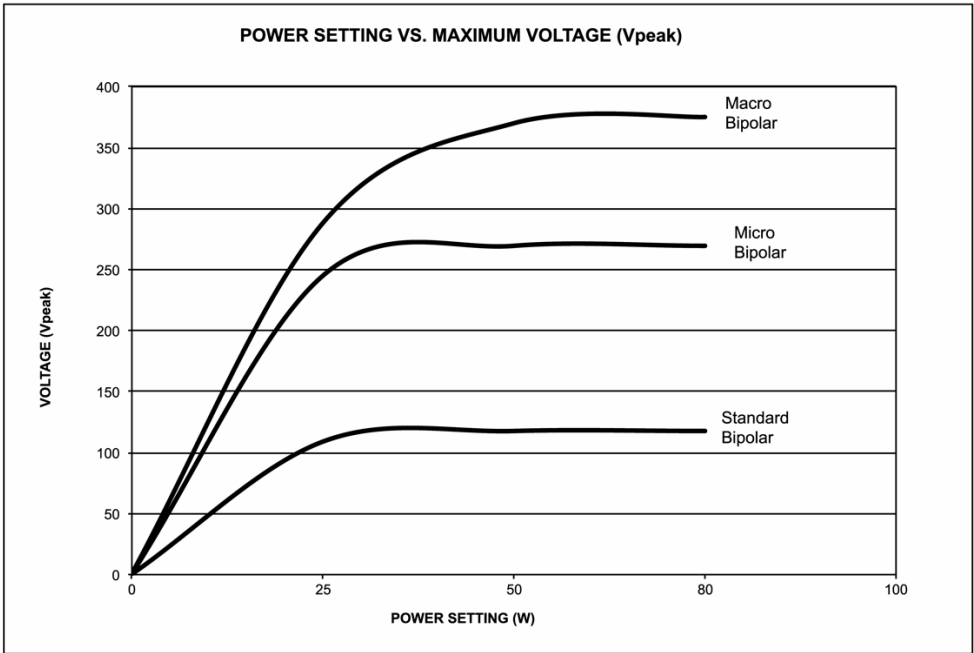

Figure 3 – 4 Output power all modes versus power setting at rated loads

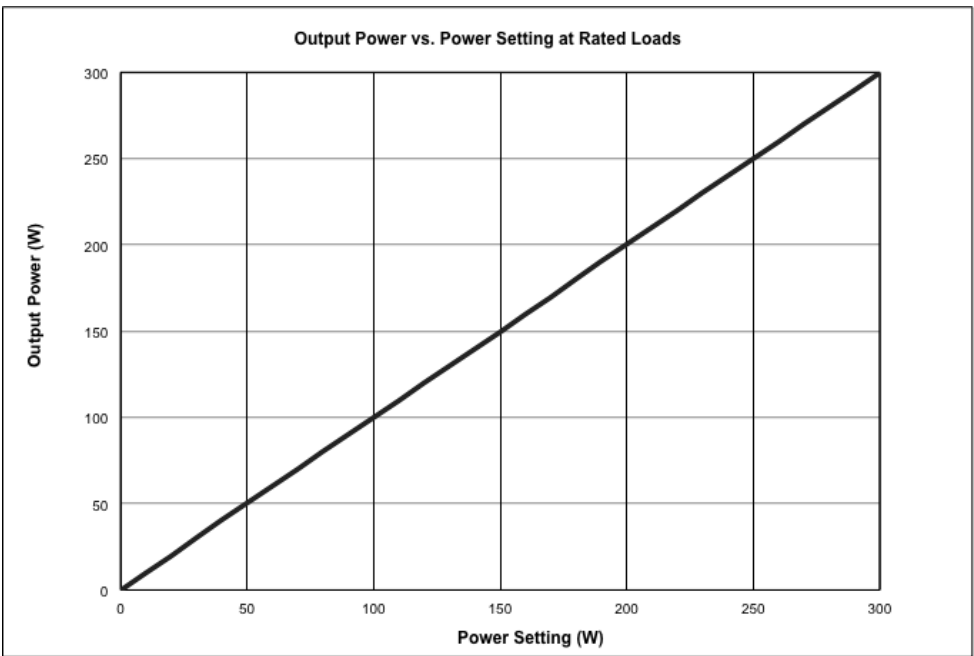

Figure 3 – 5 Output power versus impedance for Cut I mode

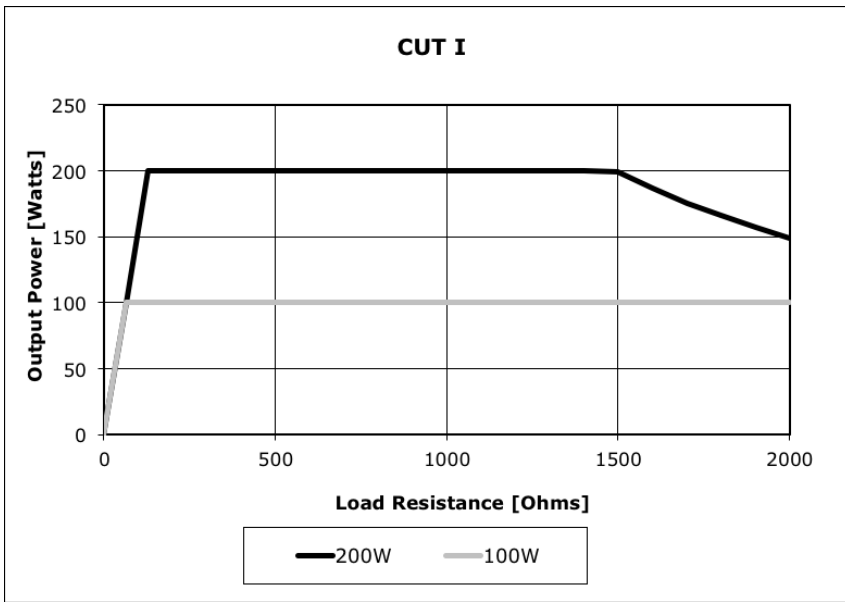

Figure 3 – 6 Output power versus impedance for Cut II mode

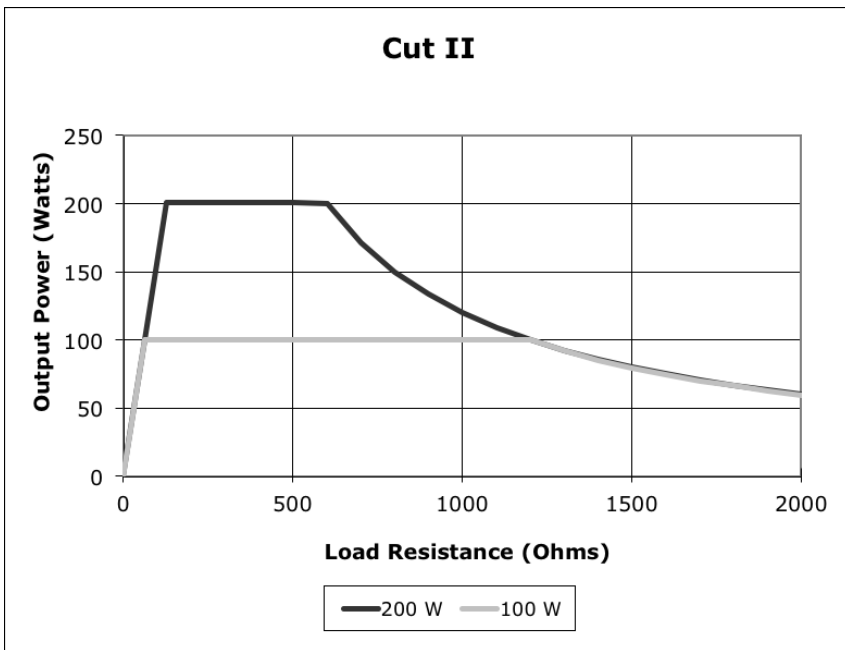

Figure 3 – 7 Output power versus impedance for Blend (1, 2, 3, 4) mode

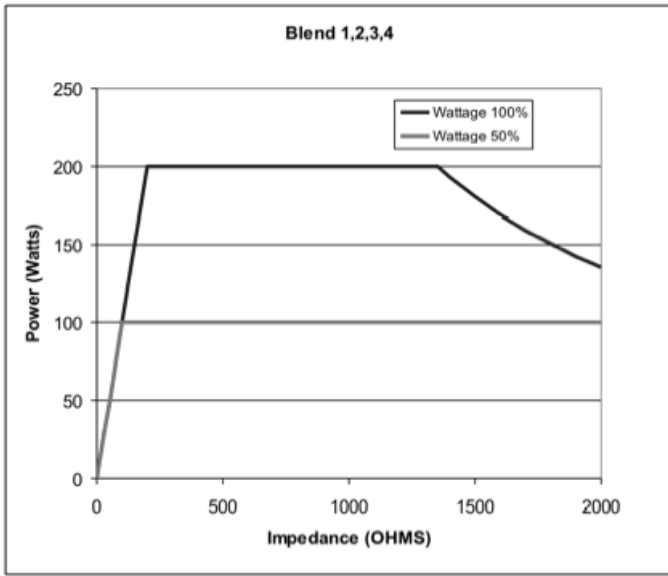

Figure 3 – 8 Output power vs impedance for Pinpoint mode

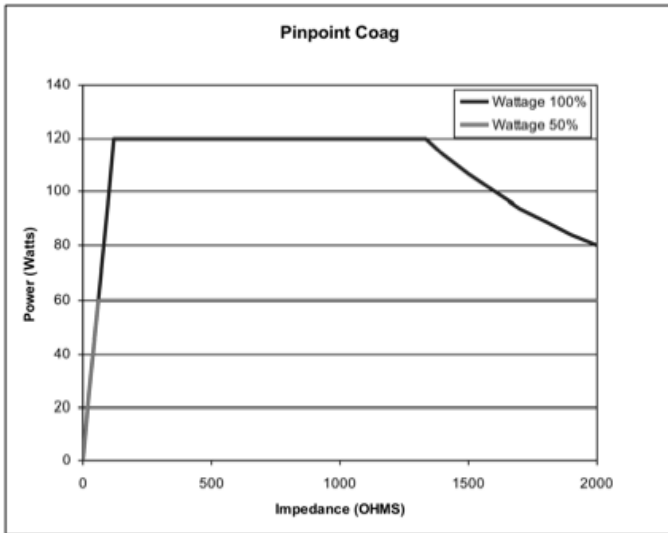

Figure 3- 9 Output power vs impedance for Spray mode

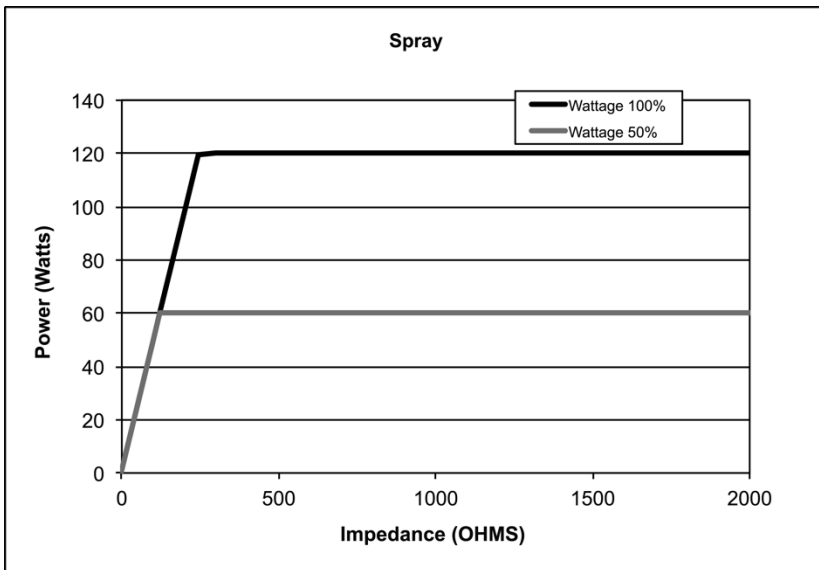

Figure 3 - 10 Output power vs impedance for Gentle Coagulation mode

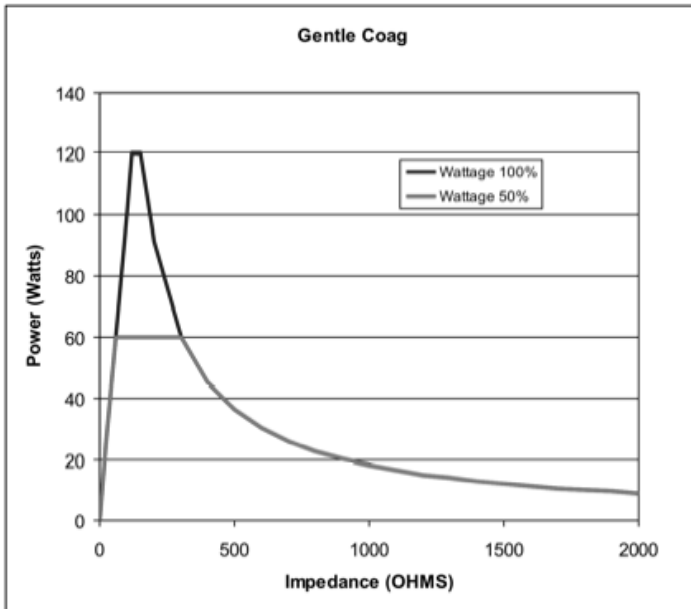

Figure 3- 11 Output power vs impedance for Macro Bipolar mode

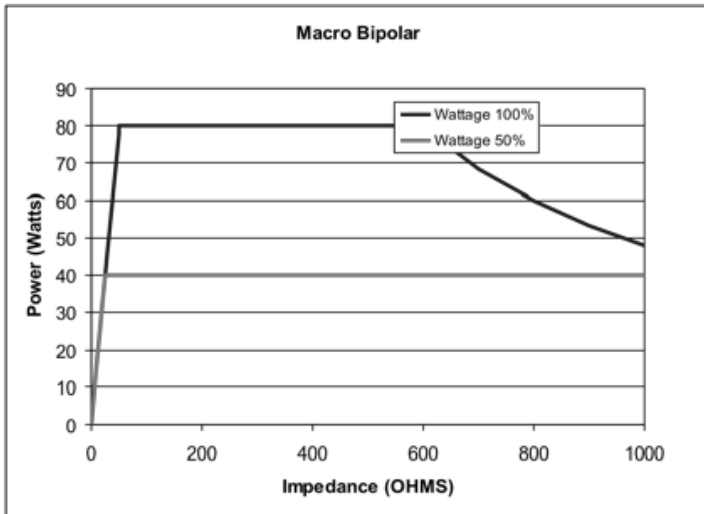

Figure 3- 12 Output power vs impedance for Micro Bipolar mode

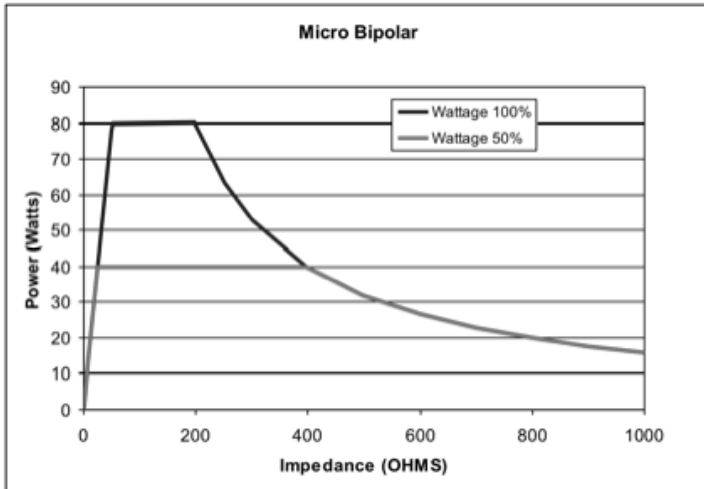

Figure 3- 13 Output power vs impedance for Standard Bipolar mode

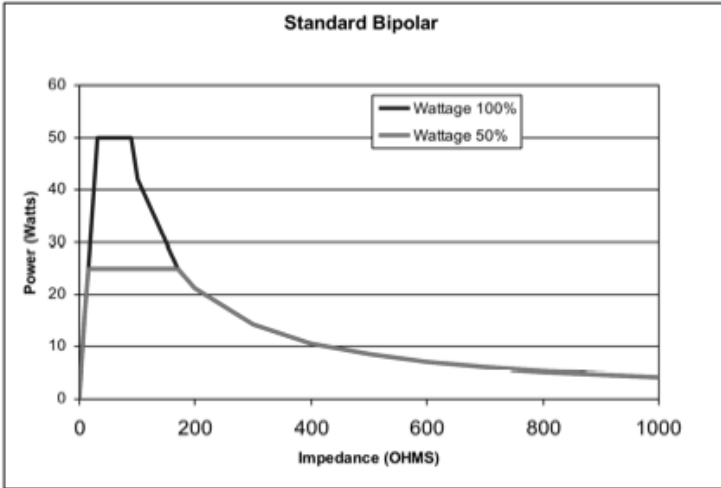

Figure 3- 14 Cut I Output Waveform (300 Ohm Load)

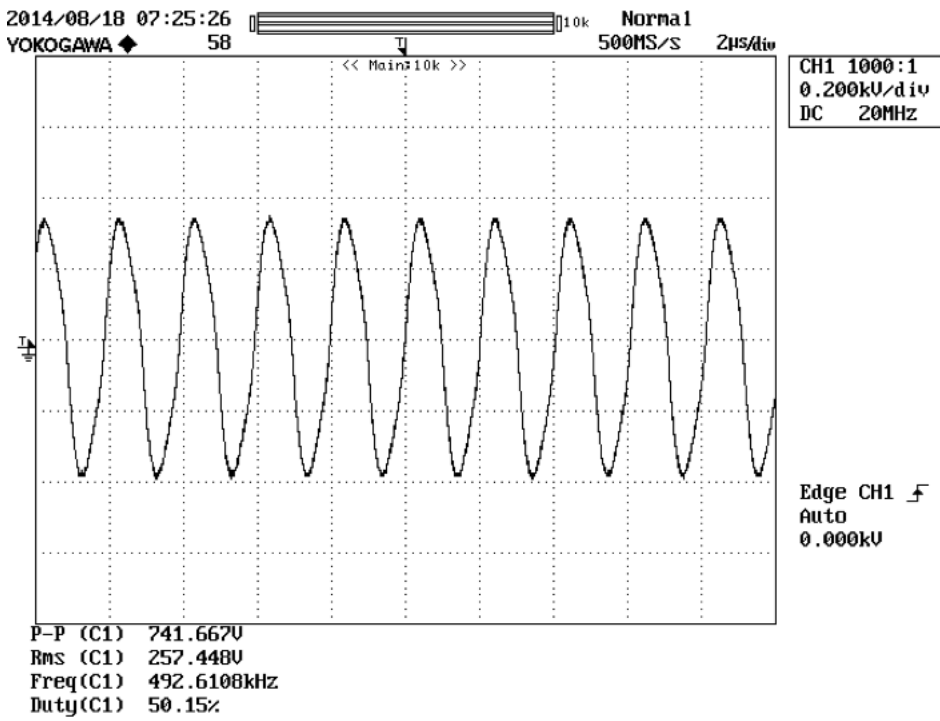

Figure 3- 15 Cut II Output Waveform (300 Ohm Load)

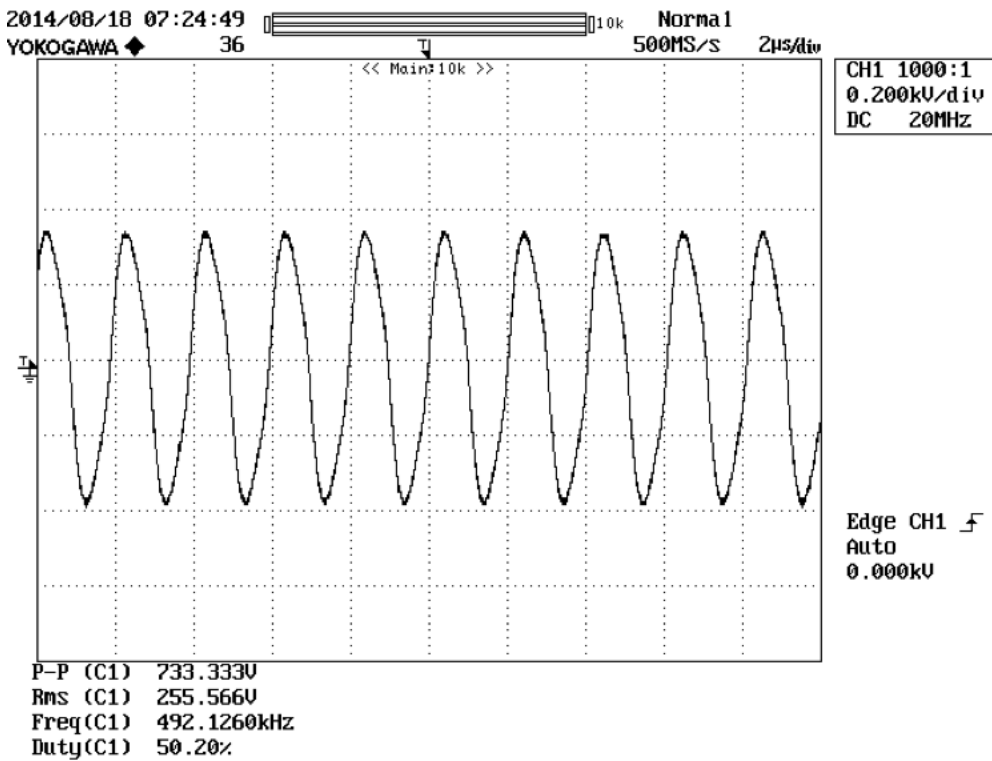

Figure 3-16 Blend 1 Output Waveform (2000 Ohm Load)

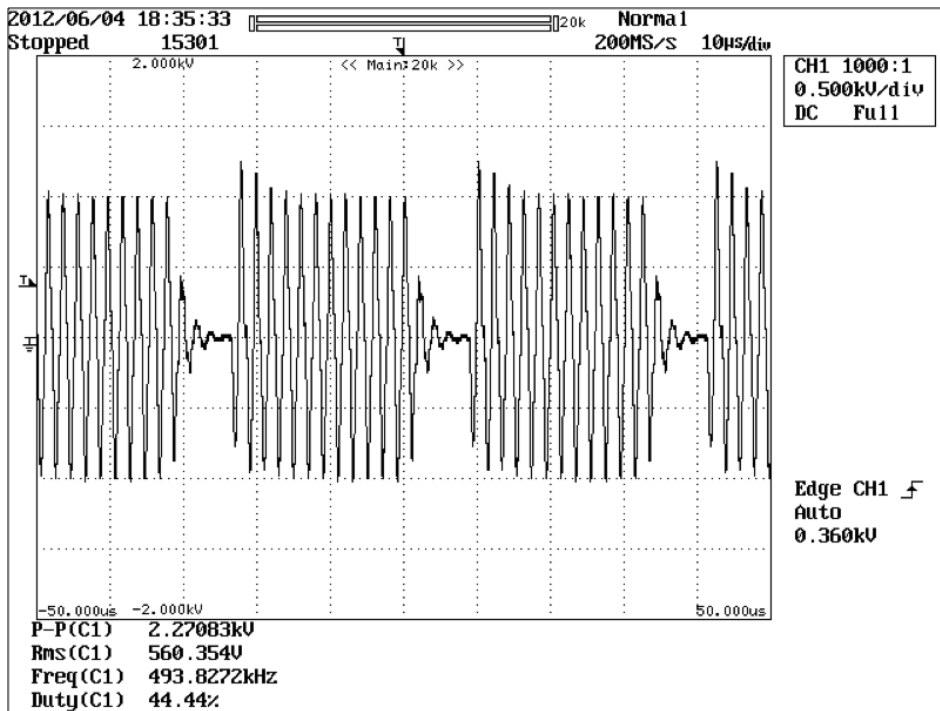

Figure 3-17 Blend 2 Output Waveform (2000 Ohm Load)

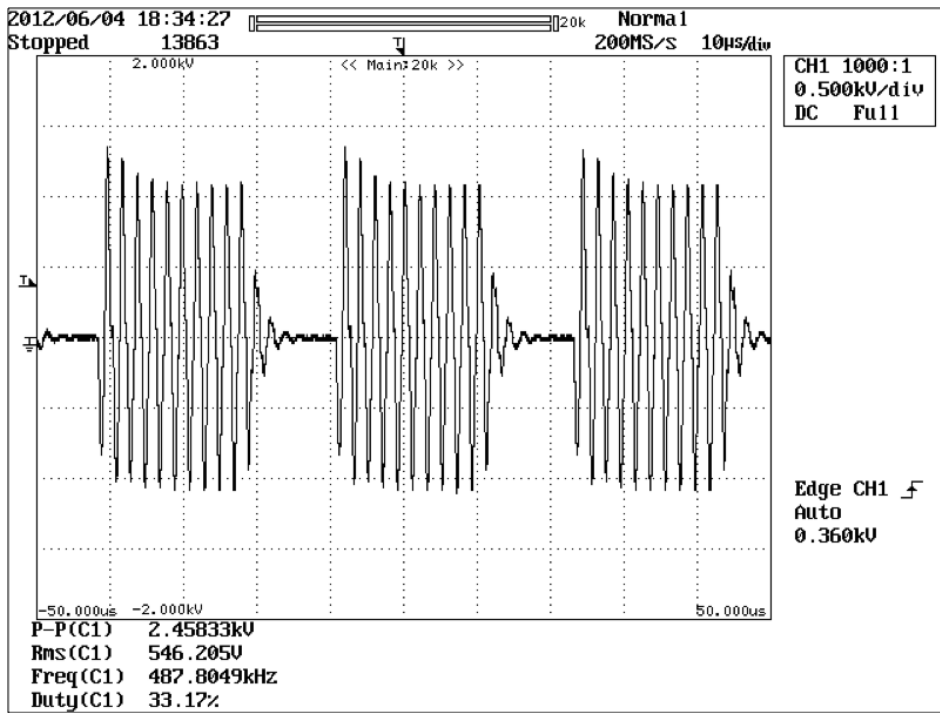

Figure 3- 18 Blend 3 Output Waveform (2000 Ohm Load)

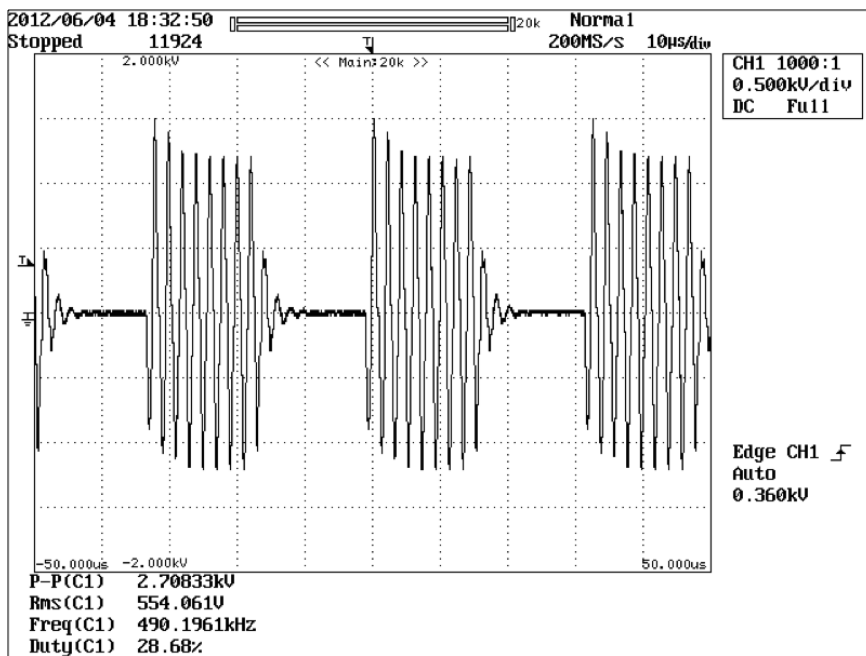

Figure 3- 19 Blend 4 Output Waveform (2000 Ohm Load)

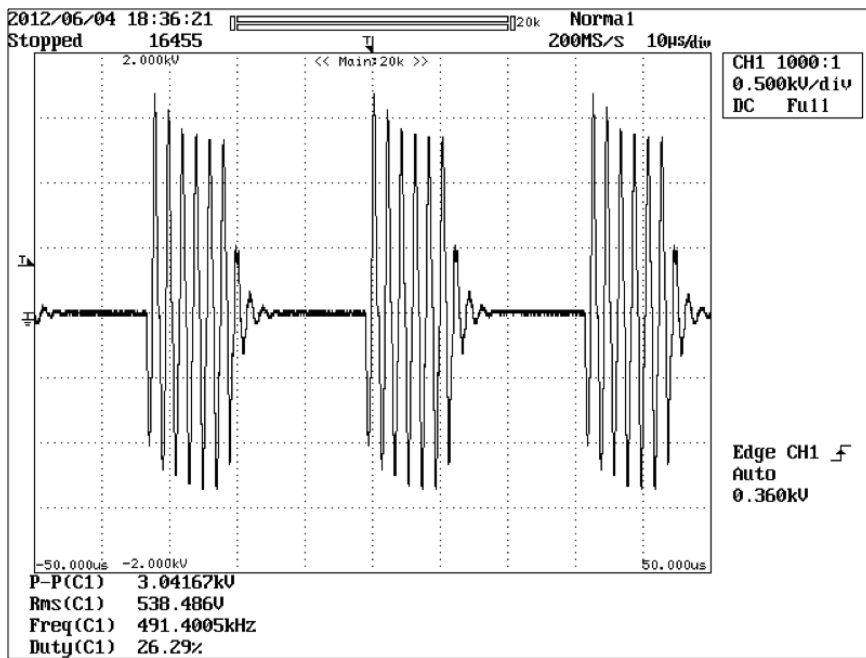

Figure 3– 20 Pinpoint Coagulation Output Waveform (2000 Ohm Load)

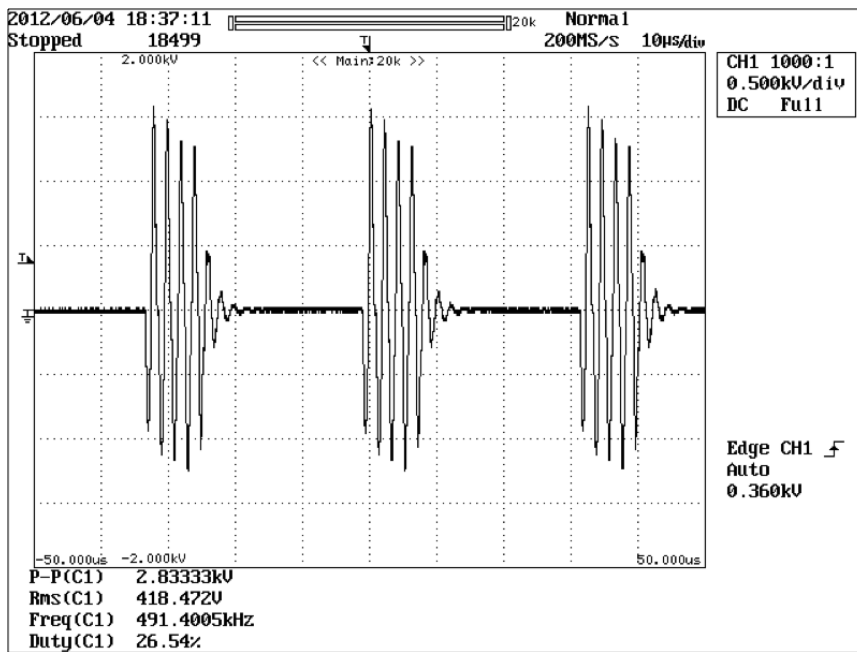

Figure 3– 21 Spray Coagulation Output Waveform (2000 Ohm Load)

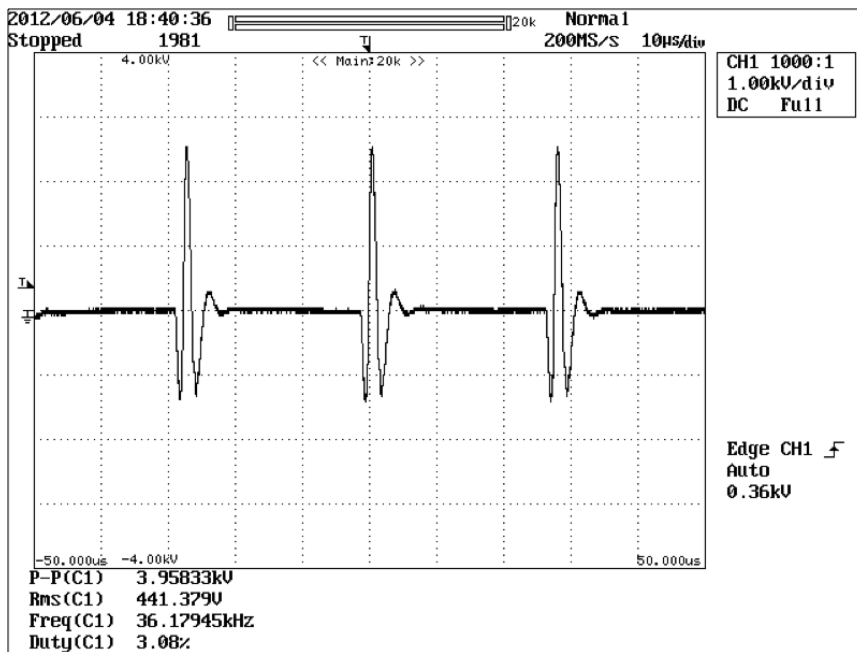

Figure 3- 22 Spray Coagulation Output Waveform (3000 Ohm Load)

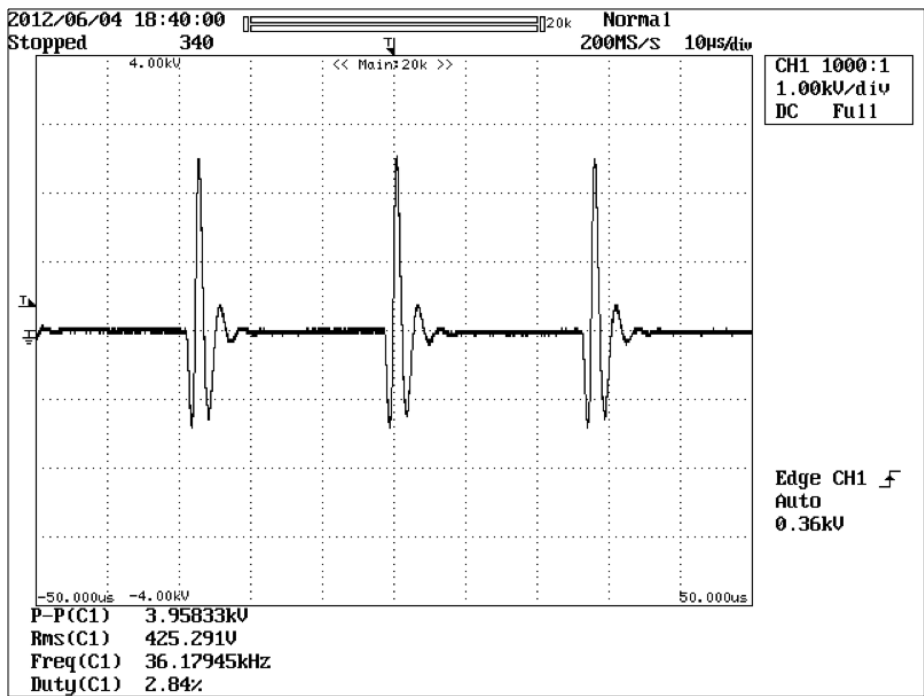

Figure 3- 23 Gentle Coagulation Output Waveform (100 Ohm Load)

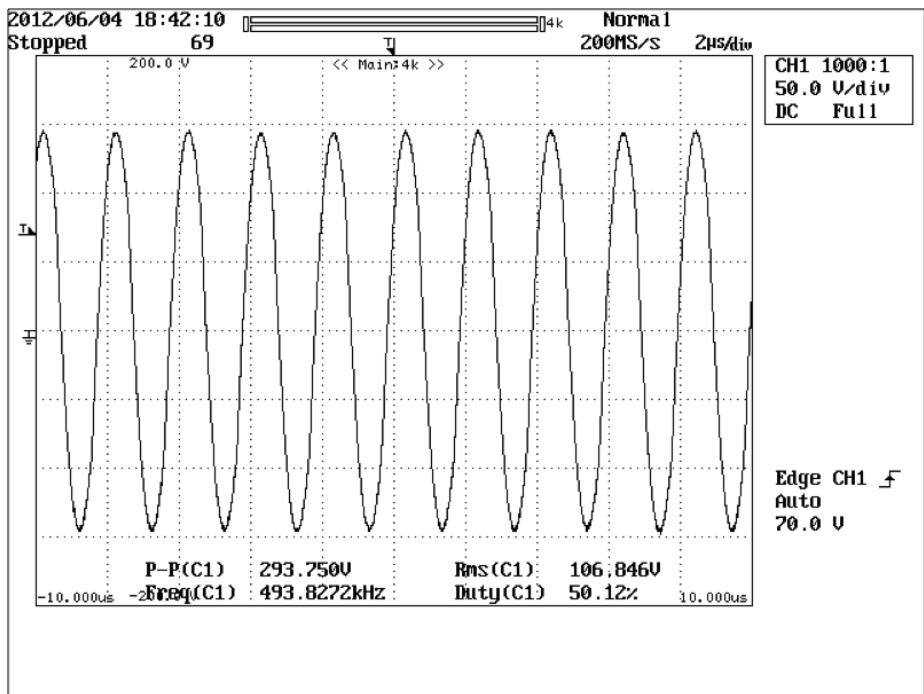

Figure 3- 24 Macro Bipolar Output Waveform (1000 Ohm Load)

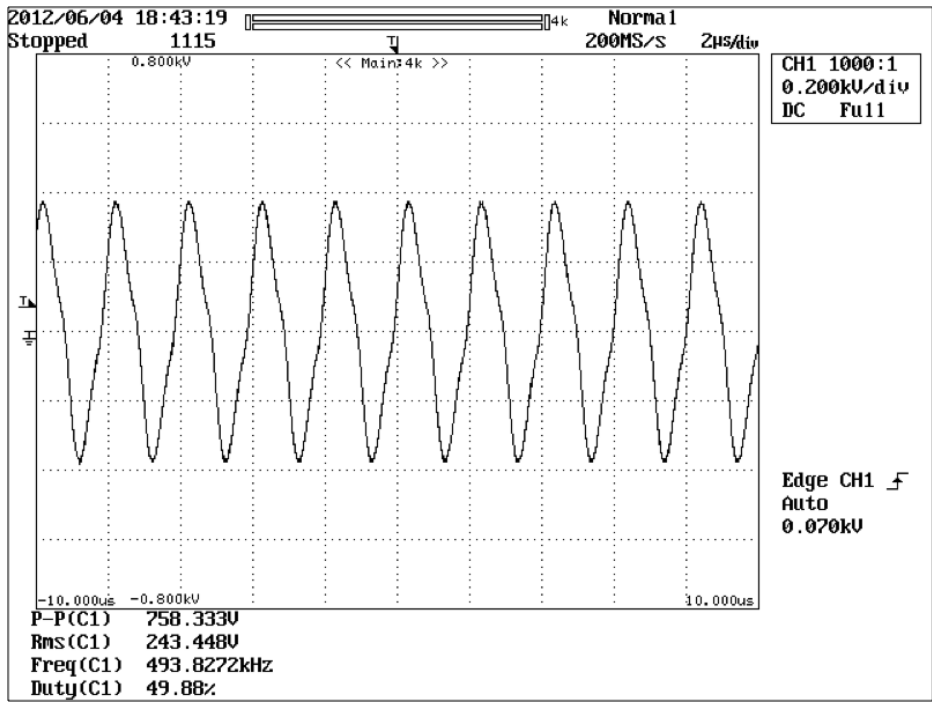

Figure 3- 25 Micro Bipolar Output Waveform (800 Ohm Load)

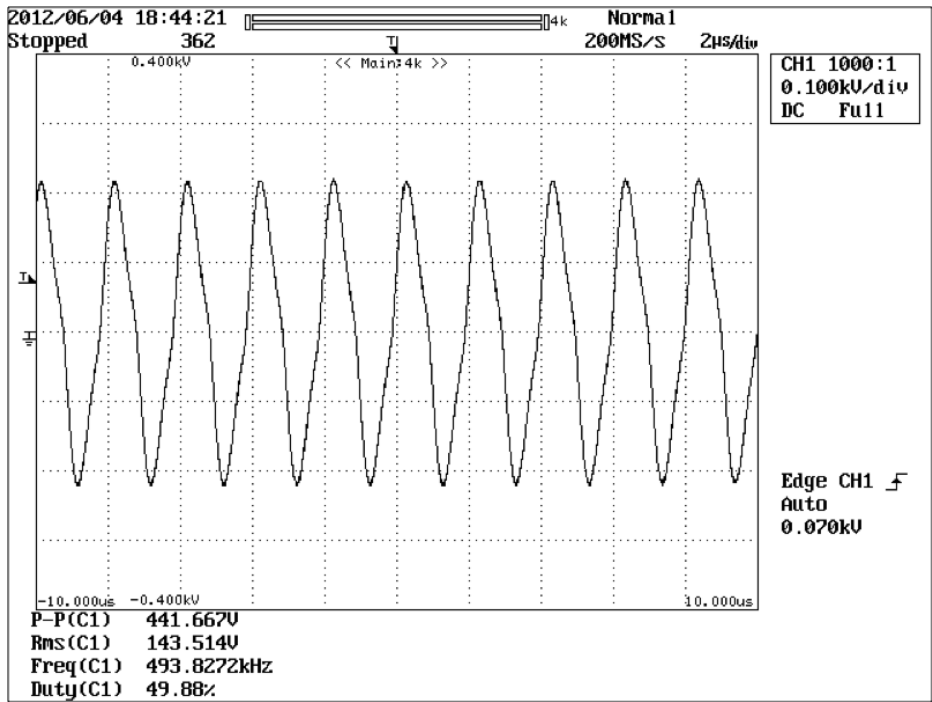
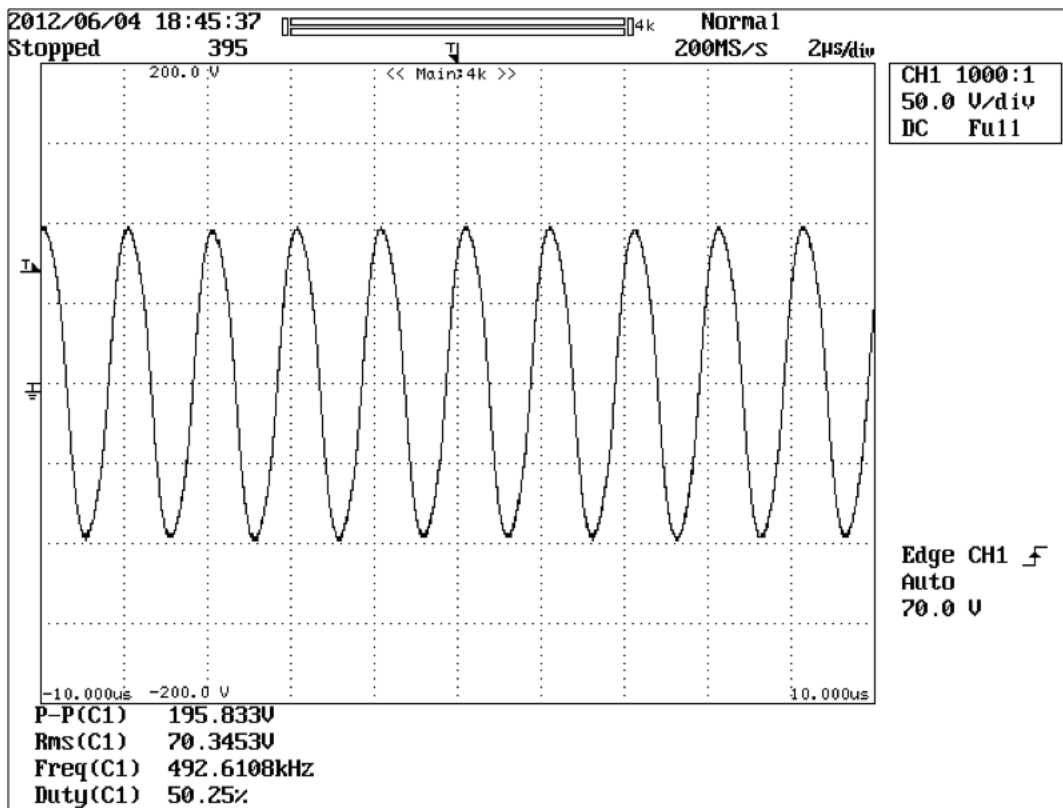

Figure 3-26 Standard Bipolar Output Waveform (200 Ohm Load)



THEORY OF OPERATION

This section contains the following information

- Block Diagram
- Functional Overview of Key Circuits
- Controls and Indicators
- Bovie® IDS-210 Control Signal Inputs and Outputs

BLOCK DIAGRAM

Figure 4 – 1 Functional Block Diagram of the Bovie® IDS-210 system.

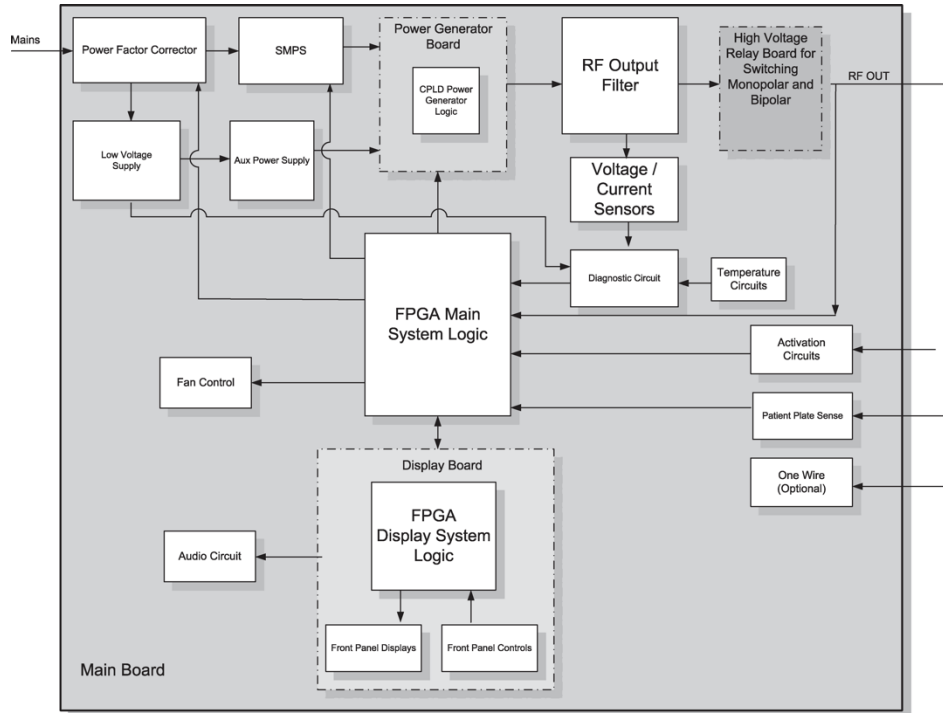

FUNCTIONAL OVERVIEW OF KEY CIRCUITS

The following descriptions highlight the main circuits in the Bovie® IDS-210.

CONTROLS AND INDICATORS

The front panel overlay contains 13 membrane function switches. Each membrane switch is used to toggle between modes, presets, and power settings. The overlay interfaces with the display PCB to control user requests.

FUNCTIONAL OVERVIEW OF MAIN BOARD

The Bovie® IDS-210 ESU has several circuits that can be grouped by its contribution to the power generation. These are High Power Circuits, Low Power Supply Circuits, Digital Control Circuits and Measurement & Monitoring Circuits.

FUNCTIONAL OVERVIEW OF HIGH POWER CIRCUITS - MAIN BOARD

The High Power Circuits are responsible for the generation of power, applied to the patient. The maximum power is 300W in CUT mode. The maximum peak voltage is achieved in Fulguration – 3200V, the maximum current is in Bovie® Bipolar Mode – 3A.

MAIN BOARD POWER FACTOR CORRECTOR

The PFC is built overactive, boost topology, and is using an IGBT as an active element. The PFC is working with universal input mains voltage 100V-240V and is producing an output $V=380V$. During stand-by mode, the PFC is disabled, in order to minimize the EMI. The working Power Factor is between 0.95-0.99. The circuit has an overvoltage protection varistor, common-mode filter for noise reduction and fuse.

MAIN BOARD FULL BRIDGE SMPS

The SMPS, which is fed by the PFC, is built over the full-bridge topology and is digitally controlled by pulse width Modulation (PWM) to provide variable power supply for the Bovie® IDS-210 Power Generator. The value of the output voltage is directly connected with the current value of the patient's tissue impedance, due to the closedloop system. The SMPS operates at 100 kHz and the output voltage varies between 16V -232V.

MAIN BOARD PUSH PULL POWER GENERATOR

The Power Generator is built as a push-pull MOSFET amplifier, The generator is using a combination of transformers, which effectively is increasing the leakage inductance, which forms filter and impedance matching circuit with the output winding capacitance. This substantially increases the ability of the generator to work with high currents and output high voltages. The generator has short-circuit protection, implemented by cycle-by-cycle current limiting circuit. The generator is having a damping circuit which is working for all modulated modes – BLEND, PINPOINT, and FULGURATION. This circuit effectively suppresses the ringing in the pauses of the modulation circuit by dissipating energy a resistor. The ringing is due to energy stored (and not exhausted) in the resonant tank, formed by the transformer primary inductance and the push-pull transistors output capacitance.

The power generator has relays – they are switching the number of the primary turns in FULGURATION mode, thus increasing the transformer ratio to get higher peak voltage in the output. The power Generator is working at 492 kHz, and the damping circuit- at 1MHz.

HIGH VOLTAGE RELAYS AND MODE OUTPUT SELECT

The Power Generator output is fed to the relay board, where the mode selection HV relays are and the VI sensors (voltage and current sensors). Then the output is directed to the HV relays on the main Board, where the power is directed to the desired accessory output – Monopolar 1, Monopolar 2 or Bipolar.

LOW VOLTAGE FLYBACK SMPS AND VOLTAGE REGULATORS

The low voltage power supply is a flyback, universal mains input SMPS, with maximum power output of 30W. Together with the linear voltage regulators, the flyback LVSMPS provides several DC voltages - 16V, 12V, -12V, 5V, 3.3V and 1.2V. These voltages are used to provide power supply to the analogue and digital circuit on the main board.

SMPS DRIVER CIRCUIT

The SMPS driver circuit is used to provide the proper timing and proper PWM for the High Power SMPS. The driver generates 2 signals – SMPS_DRV1 and SMPS_DRV2 at 100 kHz.

POWER GENERATOR DRIVER CIRCUIT

The PG driver circuit is used to provide the proper timing and proper PWM for the Power Generator. The driver generates 2 signals – RF_DRV1 and RF_DRV2 at 492 kHz. The damping driver works at 1MHz (4 consecutive pulses).

OPTOISOLATED RELAY CONTROL INTERFACE

The signals that control the HV voltage relays are optoisolated for better noise immunity. The block is using a relay decoder circuit to generate all relay control codes for different modes of operation and different output accessory. Each combination is unique and is used to redirect the power to the proper output, with respect to the current activation request.

AUDIO CONTROL CIRCUIT

The circuit controls the speaker of the Bovie® IDS-210 with different activation tones and alarm tones. The control signals are generated from the display board. The volume for the activation tones maybe adjusted from the rear of the Bovie® IDS-210.

NOTICE:

Alarm volume cannot be adjusted up or down.

AUXILIARY RELAY OUTPUT

The Auxiliary Relay output is implemented with the relay K1, which is closing its contacts for every power activation and 3 seconds after the activation is terminated. The connector is connected to the rear of the Bovie® IDS-210.

HANDLE ACTIVATION AND FOOT-CONTROL RECOGNITION CIRCUITS

They provide the user with handle power activation capabilities. The handle activation circuits are implemented with Activation Module. It has 4 separate activation circuits – 2 for Monopolar 1 accessory, and 2 for Monopolar 2 accessory.

The recognition circuit is used to detect whether there is a foot-control accessory, plugged in the Monopolar 1 connector.

FOOTSWITCH ACTIVATION AND FOOT-SWITCH RECOGNITION CIRCUITS

They provide the user with footswitch power activation capabilities. The footswitch activation circuits are implemented with Activation Module. It has 4 separate activation circuits which include 2 for Monopolar Footswitch, and 2 for Bipolar accessory – Activation and recognition.

The recognition circuit for Monopolar Footswitch is implemented with a Colpitz Oscillator circuit.

NEM MONITORING CIRCUIT

The circuit is continually monitoring the quality of the contact between the patient and the split return electrode. This helps to eliminate patient burns at the return electrode side. The circuit also detects whether split or non-split electrode is attached to the system. The NEM circuit is working with dedicated voltage regulators 8.5V and -8.5V.

TEMPERATURE SENSING CIRCUITS AND DC VOLTAGE MONITORING

The diagnostic circuit in Bovie® IDS-210 is implemented with an 8 channel ADC. If the temperature exceeds some critical temperature, then an alarm triggers and the power activation is stopped. The diagnostic circuit monitors also the critical DC voltages: 3.3V, 5V, 8.5V, -8.5V.

FPGA CONTROL BLOCK

The block is using Field programmable Gate Array Logic. It performs all control and monitoring operations in the Bovie® IDS-210. A system Clock Circuit provides the basic clock frequency of 20MHz. The clock frequencies for the SMPS control are derived from the in-chip PLL (phased-locked loop) of 160MHz. The FPGA calculates in real-time the RMS values of the load current and voltage and controls the SMPS PWM in order to keep the predefined mode power curves (see below) and current power settings.

HIGH SPEED ANALOG-TO-DIGITAL CONVERTERS

The block is used to perform analog to digital conversion of the analog signals that are coming from voltage and current sensors. There are 2 identical measurement circuits (main and backup) which are essential for the safety of the closed-loop control system. The ADCs are working at 5MHz clock frequency. The main ADC has a 10 bit resolution, and the backup ADC -8 bit. Both ADCs are working with differential, symmetrical input for better noise immunity.

1-WIRE INTERFACE BLOCK (OPTIONAL CIRCUIT)

The block is optional for Bovie® IDS-210 and is designated to control a future smart Bipolar Accessory. The 1-wire signal that goes to the Bipolar accessory is isolated from the FPGA with a 1-wire module. The module provides also auxiliary 5V power supply.

MULTI-BUTTON HANDLE SUPPORT (OPTIONAL CIRCUIT)

The block is optional for Bovie® IDS-210 and is designated to control a future smart Monopolar Accessory, that has more than 2 buttons (for example Power Up and Power Down buttons) The most important is that this type of control is not increasing the number of the control wires in the Monopolar Accessory- they remain three.

VOLTAGE MAIN AND BACKUP SENSOR

The block is used measure the output voltage. The signal VS_Scale is used to scale the voltage sensor output by a factor of 2, thus optimizing the dynamic response and resolution. The scaling is working only for the main sensor and not for the backup sensor.

CURRENT MAIN AND BACKUP SENSOR

The block is used measure the output current. The signal CS_Scale is used to scale the current sensor output by a factor of 2, thus optimizing the dynamic response and resolution. The scaling is working only for the main sensor and not for the backup one.

CONTROLS AND INDICATORS

The Bovie® IDS-210 controls and indicators are listed below:

- MEMBRANE SWITCHES Toggle between modes, settings and selections.
- DISPLAYS Three separate displays (Cut, Coag, & Bipolar) indicate the power in watts.
- PRESETS Recall (select), set, and view physician selected power settings saved in the 10-memory mode and power set feature.
- MODE INDICATORS (see table below).
- POWER CONTROL SWITCHES These membrane switches adjust the output power for each mode.
- POWER SWITCH A double pole single throw switch that snaps into the front bezel. This switch supplies the AC mains current to the generator.

BOVIE® IDS-310 CONTROL SIGNAL INPUTS AND OUTPUTS

The following table lists the important input and output signals. From a troubleshooting standpoint, the absence (and presence) of these signals will assist in isolating problems.

Continued on following pages.

PFC_ON	This is an output signal from the system logic to the Power Factor Corrector Circuit. Used to toggle the PFC circuit on and off.
SMPS_RANGE	This is an output signal from the system logic to the SMPS to control the output voltage range.
SMPS_DRV	This is an output signal from the system logic that generates the drive signals for the SMPS.
SMPS_DRV1	This is an output signal from the system logic that generates the drive signals for the SMPS.

DISP_RST	This is a communication signal from the system logic to the display system logic.
DISP_INT	This is a communication signal from the system logic to the display system logic.
DISP_CLK	This is a communication signal from the system logic to the display system logic.
DISP_DIN	This is a communication signal from the system logic to the display system logic.
DISP_DOUT	This is a communication signal from the system logic to the display system logic.
DISP_SELECT	This is a communication signal from the system logic to the display system logic.
DISP_INT_CLR	This is a communication signal from the system logic to the display system logic.
TEMP_1	This is an input signal from temperature sensor 1 to the system logic. Used to monitor the internal temperature of the unit.
TEMP_2	This is an input signal from temperature sensor 2 to the system logic. Used to monitor the internal temperature of the unit.
I_TRANS_1	This is an input signal from the current sensor to the system logic. Used to monitor the output current of the unit.
I_TRANS_2	This is an input signal from the current sensor to the system logic. Used to monitor the output current of the unit.
I_TRANS_3	This is an input signal from the current sensor to the system logic. Used to monitor the output current of the unit.
IB_TRANS_1	This is an input signal from the backup current sensor to the system logic. Used to monitor the output current of the unit.
IB_TRANS_2	This is an input signal from the backup current sensor to the system logic. Used to monitor the output current of the unit.
IB_TRANS_3	This is an input signal from the backup current sensor to the system logic. Used to monitor the output current of the unit.
V_TRANS_1	This is an input signal from the voltage sensor to the system logic. Used to monitor the output voltage of the unit.
V_TRANS_2	This is an input signal from the voltage sensor to the system logic. Used to monitor the output voltage of the unit.
V_TRANS_3	This is an input signal from the voltage sensor to the system logic. Used to monitor the output voltage of the unit.
VB_TRANS_1	This is an input signal from the backup voltage sensor to the system logic. Used to monitor the output voltage of the unit.
VB_TRANS_2	This is an input signal from the backup voltage sensor to the system logic. Used to monitor the output voltage of the unit.
VB_TRANS_3	This is an input signal from the backup voltage sensor to the system logic. Used to monitor the output voltage of the unit.

VS_SCALE	This is an output signal from the system logic for scaling the voltage sensors.
CS_SCALE	This is an output signal from the system logic for scaling the current sensors
PUMP_DIN	Reserved.
PUMP_SCLK	Reserved.
PUMP_CS	Reserved.
AUX_SWITCH	These are output signals from the system logic to control the bipolar display.
FAN_CTRL	This is an output signal from the system logic to the fan circuit. Used to toggle the fan on and off.
RF_DRV1	This is an output signal from the system logic that generates the driving signal for the output stage.
RF_DRV2	This is an output signal from the system logic that generates the driving signal for the output stage.
RF_DAMP	This is an output signal from the system logic to control the damping of the output.
CUT/COAG	This is an output signal that defines the modulation signal to the output stage.
RELAY_CABLE_CHECK	This is an input signal that monitors the presence of the Relay Cable.
NEM_T1	This is a input signal from the NEM circuit to the system logic for monitoring the NEM status.
NEM_T2	This is a input signal from the NEM circuit to the system logic for monitoring the NEM status.
OUT_RLY_LO_FPGA	This is an output signal from the system logic to configure the output relays.
MONOBIPOLAR_MODE_FPGA	This is an output signal from the system logic to configure the output relays.
HANDLE_OUT_RLY_FPGA	This is an output signal from the system logic to configure the output relays.
FOOTC_OUT_RLY_FPGA	This is an output signal from the system logic to configure the output relays.

HNDL1_COAG	This is an input signal from the activation module for sensing activation requests from handle 1 coagulation.
HNDL1_CUT	This is an input signal from the activation module for sensing activation requests from handle 1 cut.
HNDL1_UPDN	Reserved
HNDL2_COAG	This is an input signal from the activation module for sensing activation requests from handle 2 coagulation.
HNDL2_UPDN	Reserved
HNDL2_CUT	This is an input signal from the activation module for sensing activation requests from handle 2 cut.
FSW_BI_RECG	This is an input signal from the activation module for sensing the presence of a connected bipolar footswitch.
FSW_BIPOLAR_ACT	This is an input signal from the activation module for sensing activation requests from the bipolar footswitch.
FOOTC_RECG	This is an input signal from the activation module for sensing the presence of a connected footcontrolled monopolar accessory.
FOOT_COAG	This is an input signal from the activation module for sensing activation requests from the monopolar footswitch coag.
FSW_MONO_RECG	This is an input signal from the activation module for sensing the presence of a connected monopolar footswitch.
FOOT_CUT	This is an input signal from the activation module for sensing activation requests from the monopolar footswitch cut.
SS_EXT_IN	Reserved Communication Signal
SCLK_EXT_OUT	Reserved Communication Signal
TXRX_ENA	Reserved Communication Signal
DIN_SPI_GC	Reserved Communication Signal
DOUT_SPI_GC	Reserved Communication Signal
SCLK_SPI_GC	Reserved Communication Signal
SS_SPI_GC	Reserved Communication Signal

DISABLE_1W	This is an output signal from the system logic to toggle the 1-wire module on and off.
1_WIRE_TX	This is an output signal from the system logic to transmit data to the 1-wire module.
1_WIRE_RX	This is an input signal from the 1-wire module to the system logic to receive data.
CS_SCALE	This is an output signal from the system logic for scaling the voltage sensors.
VS_SCALE	This is an output signal from the system logic for scaling the current sensors.
IB_TRANS_1	This is an output signal from the backup current sensor to the system logic. Used to monitor the output current of the unit.
IB_TRANS_2	This is an output signal from the backup current sensor to the system logic. Used to monitor the output current of the unit.
IB_TRANS_3	This is an output signal from the backup current sensor to the system logic. Used to monitor the output current of the unit.
VB_TRANS_1	This is an output signal from the backup voltage sensor to the system logic. Used to monitor the output voltage of the unit.
VB_TRANS_2	This is an output signal from the backup voltage sensor to the system logic. Used to monitor the output voltage of the unit.
VB_TRANS_3	This is an output signal from the backup voltage sensor to the system logic. Used to monitor the output voltage of the unit.
I_TRANS_3	This is an output signal from the current sensor to the system logic. Used to monitor the output current of the unit.
I_TRANS_2	This is an output signal from the current sensor to the system logic. Used to monitor the output current of the unit.
I_TRANS_1	This is an output signal from the current sensor to the system logic. Used to monitor the output current of the unit.
V_TRANS_1	This is an output signal from the current sensor to the system logic. Used to monitor the output current of the unit.
V_TRANS_2	This is an output signal from the current sensor to the system logic. Used to monitor the output current of the unit.
V_TRANS_3	This is an output signal from the current sensor to the system logic. Used to monitor the output current of the unit.
DISP_B1_DP	This is an output signal from the system logic to control the Bipolar Display.
DISP_B1_G	This is an output signal from the system logic to control the Bipolar Display.
DISP_B1_F	This is an output signal from the system logic to control the Bipolar Display.

DISP_B1_E	This is an output signal from the system logic to control the Bipolar Display.
DISP_B1_D	This is an output signal from the system logic to control the Bipolar Display.
DISP_B1_C	This is an output signal from the system logic to control the Bipolar Display.
DISP_B1_B	This is an output signal from the system logic to control the Bipolar Display.
DISP_B1_A	This is an output signal from the system logic to control the Bipolar Display.
DISP_B2_DP	This is an output signal from the system logic to control the Bipolar Display.
DISP_B2_G	This is an output signal from the system logic to control the Bipolar Display.
DISP_B2_F	This is an output signal from the system logic to control the Bipolar Display.
DISP_B2_E	This is an output signal from the system logic to control the Bipolar Display.
DISP_B2_D	This is an output signal from the system logic to control the Bipolar Display.
IDISP_B2_C	This is an output signal from the system logic to control the Bipolar Display.
DISP_B2_B	This is an output signal from the system logic to control the Bipolar Display.
DISP_B2_A	This is an output signal from the system logic to control the Bipolar Display.
DISP_B3_DP	This is an output signal from the system logic to control the Bipolar Display.
DISP_B3_G	This is an output signal from the system logic to control the Bipolar Display.
DISP_B3_F	This is an output signal from the system logic to control the Bipolar Display.
DISP_B3_E	This is an output signal from the system logic to control the Bipolar Display.
DISP_B3_D	This is an output signal from the system logic to control the Bipolar Display.
DISP_B3_C	This is an output signal from the system logic to control the Bipolar Display.
DISP_B3_B	This is an output signal from the system logic to control the Bipolar Display.
DISP_B3_A	This is an output signal from the system logic to control the Bipolar Display.
DISP_A1_A	This is an output signal from the system logic to control the Cut Display.
DISP_A1_B	This is an output signal from the system logic to control the Cut Display.
DISP_A1_C	This is an output signal from the system logic to control the Cut Display.
DISP_A1_D	This is an output signal from the system logic to control the Cut Display.
DISP_A1_E	This is an output signal from the system logic to control the Cut Display.
DISP_A1_F	This is an output signal from the system logic to control the Cut Display.
DISP_A1_G	This is an output signal from the system logic to control the Cut Display.
DISP_A1_DP	This is an output signal from the system logic to control the Cut Display.
DISP_A2_A	This is an output signal from the system logic to control the Cut Display.
DISP_A2_B	This is an output signal from the system logic to control the Cut Display.
DISP_A2_C	This is an output signal from the system logic to control the Cut Display.
DISP_A2_D	This is an output signal from the system logic to control the Cut Display.
DISP_A2_E	This is an output signal from the system logic to control the Cut Display.
DISP_A2_F	This is an output signal from the system logic to control the Cut Display.

DISP_A1_G	This is an output signal from the system logic to control the Cut Display.
DISP_A1_DP	This is an output signal from the system logic to control the Cut Display.
DISP_A2_A	This is an output signal from the system logic to control the Cut Display.
DISP_A2_B	This is an output signal from the system logic to control the Cut Display.
DISP_A2_C	This is an output signal from the system logic to control the Cut Display.
DISP_A2_D	This is an output signal from the system logic to control the Cut Display.
DISP_A2_E	This is an output signal from the system logic to control the Cut Display.
DISP_A2_F	This is an output signal from the system logic to control the Cut Display.
DISP_A2_G	This is an output signal from the system logic to control the Cut Display.
DISP_A2_DP	This is an output signal from the system logic to control the Cut Display.
DISP_A3_A	This is an output signal from the system logic to control the Cut Display.
DISP_A3_B	This is an output signal from the system logic to control the Cut Display.
DISP_A3_C	This is an output signal from the system logic to control the Cut Display.
DISP_A3_D	This is an output signal from the system logic to control the Cut Display.
DISP_A3_E	This is an output signal from the system logic to control the Cut Display.
DISP_A3_F	This is an output signal from the system logic to control the Cut Display.
DISP_A3_G	This is an output signal from the system logic to control the Cut Display.
DISP_A3_DP	This is an output signal from the system logic to control the Cut Display.
DISP_C1_A	This is an output signal from the system logic to control the Coag Display.
DISP_C1_B	This is an output signal from the system logic to control the Coag Display.
DISP_C1_C	This is an output signal from the system logic to control the Coag Display.
DISP_C1_D	This is an output signal from the system logic to control the Coag Display.
DISP_C1_E	This is an output signal from the system logic to control the Coag Display.
DISP_C1_F	This is an output signal from the system logic to control the Coag Display.
DISP_C1_G	This is an output signal from the system logic to control the Coag Display.
DISP_C1_DP	This is an output signal from the system logic to control the Coag Display.
DISP_C2_A	This is an output signal from the system logic to control the Coag Display.
DISP_C2_B	This is an output signal from the system logic to control the Coag Display.
DISP_C2_C	This is an output signal from the system logic to control the Coag Display.
DISP_C2_D	This is an output signal from the system logic to control the Coag Display.
DISP_C2_E	This is an output signal from the system logic to control the Coag Display.
DISP_C2_F	This is an output signal from the system logic to control the Coag Display.
DISP_C2_G	This is an output signal from the system logic to control the Coag Display.

DISP_C2_DP	This is an output signal from the system logic to control the Coag Display.
DISP_C3_A	This is an output signal from the system logic to control the Coag Display.
DISP_C3_B	This is an output signal from the system logic to control the Coag Display.
DISP_C3_C	This is an output signal from the system logic to control the Coag Display.
DISP_C3_D	This is an output signal from the system logic to control the Coag Display.
DISP_C3_E	This is an output signal from the system logic to control the Coag Display.
DISP_C3_A F	This is an output signal from the system logic to control the Coag Display.
DISP_C3_G	This is an output signal from the system logic to control the Coag Display.
DISP_C3_DP	This is an output signal from the system logic to control the Coag Display.
DISP_D_A	This is an output signal from the system logic to control the Memory Display.
DISP_D_B	This is an output signal from the system logic to control the Memory Display.
DISP_D_C	This is an output signal from the system logic to control the Memory Display.
DISP_D_D	This is an output signal from the system logic to control the Memory Display.
DISP_D_E	This is an output signal from the system logic to control the Memory Display.
DISP_D_F	This is an output signal from the system logic to control the Memory Display.
DISP_D_G	This is an output signal from the system logic to control the Memory Display.
DISP_D_DP	This is an output signal from the system logic to control the Memory Display.
ALARM_IND	This is an output signal from the system logic to control the Alarm indicator.
SPLIT_IND	This is an output signal from the system logic to control the Split Pad indicator
NON_SPLIT_IND	This is an output signal from the system logic to control the Solid Pad indicator.
BI_MICRO_IND	This is an output signal from the system logic to control the Micro Bipolar indicator.
BI_MACRO_IND	This is an output signal from the system logic to control the Macro Bipolar indicator.
BI_STANDARD_IND	This is an output signal from the system logic to control the Standard Bipolar indicator.
CUT_II_IND	This is an output signal from the system logic to control the Cut II indicator.
CUT_I_IND	This is an output signal from the system logic to control the Cut I indicator.
CUT_BLEND_IND	This is an output signal from the system logic to control the Blend indicator.

CUT_ACT_IND	This is an output signal from the system logic to control the Cut Activation indicator.
COAG_ACT_IND	This is an output signal from the system logic to control the Coag Activation indicator.
COAG_ACT_IND	This is an input signal from the backup voltage sensor to the control logic. Used to monitor the output voltage of the unit.
BIP_ACT_IND	This is an output signal from the system logic to control the Bipolar Activation indicator.
FULG_IND	This is an output signal from the system logic to control the Spray indicator.
COAG_IND	This is an output signal from the system logic to control the Pinpoint indicator.
SOFT_IND	This is an output signal from the system logic to control the Monopolar Footswitch indicator.
MONO_FOOT_IND	This is an output signal from the system logic to control the Gentle indicator.
BIP_FOOT_IND	This is an output signal from the system logic to control the Blend Bar indicator.
BLEND_10	Reserved
BLEND_9	Reserved
BLEND_8	Reserved
BLEND_7	Reserved
BLEND_6	Reserved
BLEND_5	Reserved
BLEND_4	This is an output signal from the system logic to control the Bipolar Footswitch indicator.
BLEND_3	This is an output signal from the system logic to control the Bipolar Footswitch indicator.
BLEND_2	This is an output signal from the system logic to control the Bipolar Footswitch indicator.
BLEND_1	This is an output signal from the system logic to control the Bipolar Footswitch indicator.

AUD_DRV	This is an output signal from the system logic to the audio circuit for controlling the alarm tone.
ALM_DRV	This is an output signal from the system logic to the audio circuit for controlling the activation tone.
COMM_RST	This is a communication signal from the system logic to the display system logic.
COMM_INT	This is a communication signal from the system logic to the display system logic.
SPI_COMM_CLK	This is a communication signal from the system logic to the display system logic.
SPI_COMM_DOUT	This is a communication signal from the system logic to the display system logic.
SPI_COMM_DIN	This is a communication signal from the system logic to the display system logic.
SPI_COMM_SEL	This is a communication signal from the system logic to the display system logic.
COMM_INT_CLR	This is a communication signal from the system logic to the display system logic.
RESERVE_SEL	Reserved
BI_MODE_SEL	This is an input signal to the system logic from the front panel overlay to toggle between Bipolar modes.
BLEND_UP_SEL	This is an input signal to the system logic from the blend up switch from the front panel overlay.
BLEND_DOWN_SEL	This is an input signal to the system logic from the blend down switch from the front panel overlay.
CUT_DOWN_SEL	This is an input signal to the system logic from the cut down switch from the front panel overlay.
CUT_UP_SEL	This is an input signal to the system logic from the cut up switch from the front panel overlay.
COAG_MODE_SEL	This is an input signal to the system logic from the front panel overlay to toggle between Coag modes.
CUT_MODE_SEL	This is an input signal to the system logic from the front panel overlay to toggle between Cut modes.
SET_SEL	This is an input signal to the system logic from the set switch front panel overlay.
RECALL_SEL	This is an input signal to the system logic from the reset switch front panel overlay.
COAG_UP_SEL	This is an input signal to the system logic from the coag up switch from the front panel overlay.
COAG_DN_SEL	This is an input signal to the system logic from the coag down switch from the front panel overlay.
BIP_DOWN_SEL	This is an input signal to the system logic from the bipolar down switch from the front panel overlay.
BIP_U_SEL	This is an input signal to the system logic from the bipolar up switch from the front panel overlay.

MAINTAINING THE BOVIE® IDS-210

This section covers the following topics:

- Cleaning
- Periodic Inspection
- Fuse Replacement

Aspen Surgical Products recommends that you complete periodic inspection and performance testing. Perform inspections and performance testing every six months. A qualified biomedical technician should conduct this testing to ensure that the unit is operating effectively and safely.

CLEANING

After each use, clean the unit.

WARNING:

Electric Shock Hazard - Always turn off and unplug the generator before cleaning.

NOTICE:

Do not clean the generator with abrasive cleaning or disinfectant compounds, solvents, or other materials that could scratch the panels or damage the generator.

1. Turn off the generator and unplug the power cord from the wall outlet.
2. Thoroughly wipe all surfaces of the generator and power cord with a mild cleaning solution or disinfectant and a damp cloth. Follow the procedures approved by your institution or use a validated infection control procedure. Do not allow fluids to enter the chassis. Do not sterilize the generator.

PERIODIC INSPECTION

Every six months, visually inspect the generator for signs of wear or damage. In particular, look for any of the following problems:

- Damage to the power cord
- Damage to the power cable receptacle
- Obvious damage to the unit
- Damage to any receptacle
- Accumulation of lint or debris in or around the unit

FUSE REPLACEMENT

Fuses for the unit reside directly below the Power Cable Receptacle on the rear of the unit.

To replace the fuses, follow this procedure:

1. Unplug the power cord from the wall outlet.
2. Remove the power cord from the Power Cable Receptacle on the rear panel.
3. To release the fuse drawer, insert a small flathead screwdriver into the slot on the drawer below the power cord receptacle. Then, slide the drawer out.
4. Remove the two fuses (T6.3AL250V) and replace them with new fuses with the same values.
5. Insert the fuse holder into the Power Cable Receptacle.

NOTICE:

If the unit does not display an error and does not power on, check fuses.

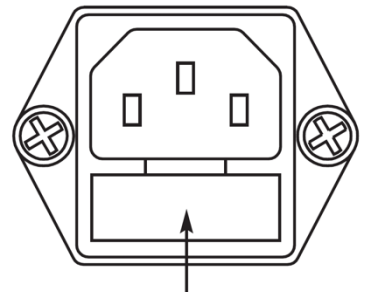

Figure 5 – 1 Fuse holder

FUSE REPLACEMENT ON THE MAIN PCB

Additional fuses for the unit reside on the Main PCB. Fuse values are indicated in the table below. To replace the fuses, follow this procedure:

1. Unplug the power cord from the wall outlet.
2. Remove the power cord from the Power Cable Receptacle on the rear panel.
3. Remove the six screws that secure the cover panel to the unit.
4. Lift off the top cover panel.
5. Disconnect ground cable from the top cover.
6. Remove the two fuses using a fuse pulling tool.
7. Replace the fuses with the same values as listed below.
8. Reinstall the cover by connecting the ground cable to the cover, positioning the cover over the chassis, and securing the six screws.

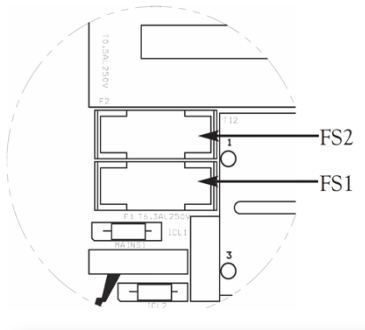

Figure 5 – 2 Fuse location

Main PCB Fuse Information

	FS1	FS2
VAC	250 VAC	250 VAC
AMPS	6.3 A	0.5 A
Slize	5 x 20 mm	5 x 20 mm
Type	Slow Blow	Slow Blow

OPERATING THE BOVIE® IDS-210

This section covers the following topics:

- Inspecting the Generator and Accessories
- Service Personnel Safety
- Installation and Placement
- Functional (operational) Checks

INSPECTING THE GENERATOR AND ACCESSORIES

Before each use of the Bovie® IDS-210, inspect the unit and all accessories to verify good working order:

- Inspect for physical damage to the generator and its connections.
- Verify that the appropriate accessories and adapters are present.
- Inspect all cords and connectors for signs of wear, damage, and abrasion.
- Verify that no error messages are displayed when the unit is turned on.

SERVICE PERSONNEL SAFETY

WARNINGS:

Hazardous Electrical Output This equipment is for operational use only by a trained, licensed, physician. Bio-Med Technicians must also exercise caution when testing or repairing a unit.

Electric Shock Hazard Connect the generator power cord to a properly grounded receptacle. Do not use power plug adapters.

Connect the power cord to a properly polarized and grounded power source with the frequency and voltage characteristics that match those listed on the back of the unit.

Fire Hazard Do not use extension cords.

CAUTIONS:

Do not stack equipment on top of the generator or place the generator on top of electrical equipment. These configurations are unstable and / or do not allow for adequate cooling.

Provide as much distance as possible between the electrosurgical generator and other electronic equipment (such as monitors). An activated electrosurgical generator may cause interference with them.

Do not turn the activation tone down to an inaudible level. This activation tone alerts the surgical team when an accessory (and the generator) is active.

When using a smoke evacuator in conjunction with the electrosurgical generator, place the smoke evacuator a distance away from the generator. Set the generator's volume control (on the rear panel) at a level that ensures all activation tones may be heard.

NOTICES:

If required by local codes, connect the generator to the hospital equalization connector with an equipotential cable. There is a equipotential connector on the rear of the unit.

Connect the power cord to a wall outlet having an acceptable voltage range. Otherwise product damage may result.

INSTALLATION AND PLACEMENT

Place the Bovie® IDS-210 on any flat surface with a tilt angle of not more than 10 degrees. The unit relies on natural convection cooling. Do not block the rear vents.

Ensure that air flows freely on all sides of the unit.

WARNING:

Connect the power cord to a properly polarized and grounded power source with the frequency and voltage characteristics that match those listed on the back of the unit.

FUNCTIONAL (OPERATIONAL) CHECKS

Refer to the figures in Controls, Indicators, and Receptacles for the location of connectors and generator controls. Use the following steps to check the general operational functions of the unit. Refer to the Troubleshooting section for technical verification checks of the unit's general operational functions.

Upon initial installation of the unit, perform the following checks:

WARNING:

At no time should you touch the active electrode or bipolar forceps.

Operating the Unit

1. Verify that the generator is Off by pressing the power switch Off (O).
2. Place the generator on a stable flat surface, such as a table, platform, or medical cart. Carts with conductive wheels are recommended. For details, refer to the procedures for your institution or to local codes. Provide at least 10 to 15 cm (4 to 6 in.) of space from the sides and top of the generator for cooling. Normally, the top, sides, and rear panel are warm when you use the generator continuously for extended periods of time.
3. Plug the generator power cord into the AC Power Cable Receptacle on the rear panel.
4. Plug the generator power cord into a grounded receptacle.
5. Turn on the generator by pressing the power switch On (—). Verify the following:
 - All visual indicators and displays on the front panel illuminate.
 - Activation tones sound to verify that the speaker is working properly.
6. If the self-test is successful, a tone sounds. Verify the following:
 - A Cut mode is selected; a Coag mode is selected.
 - Each display shows a power setting. The unit powers up to the last selected preset power setting.
 - The Patient Return Electrode Alarm Indicator illuminates red.

If the self-test is not successful, an alarm tone sounds. An error code may appear in the Cut display and/or the Coag display, in most cases, the generator is disabled. Note the error code and refer to Section 7, Troubleshooting.

Once the self-test is successful, connect the accessories and set the generator controls. Refer to Preparing for Monopolar Surgery or Preparing for Bipolar Surgery later in this section.

Preparing for Monopolar Surgery

Monopolar surgery requires a return electrode.

Applying the Return Electrode

To maximize safety, Aspen Surgical Products recommends using a split return electrode and an Bovie generator with a contact quality monitoring system (Bovie NEM™).

1. Connect the cable to the Return Electrode receptacle on the front of the unit.
The unit will automatically sense the presence of a split or solid return electrode and, if a split return electrode is used, will constantly monitor the resistance at the contact between the electrode and the patient.
2. Adjust the Blend setting to the desired amount of hemostasis (Level 1 - 10). Adjustment is performed by pressing the up or down buttons next to the Blend setting indicator.
3. Select the desired power settings for Cutting. Adjustment is performed by pressing the up or down buttons next to the Cut display. The light above the selected cut power setting illuminates.
4. Select the mode of operation for Coagulation, either Coag or Fulguration.
5. Select the desired power setting for Coagulation. Adjustment is performed by pressing the up or down buttons next to the Coag display.

Connecting Accessories

1. Connect a monopolar handpiece with electrode to the appropriate monopolar handpiece receptacle on the front of the unit.
2. If using a footswitch activated device, connect an appropriate Bovie footswitch to the monopolar footswitch connecting socket on the rear of the unit.
3. To activate the Monopolar mode, depress the cut or coag button on the monopolar handpiece or the cut or coag pedal on the monopolar footswitch.

Preparing for Bipolar Surgery

1. Connect a bipolar cable to the bipolar receptacle on the front of the unit.
2. Connect a forceps instrument to the bipolar cable.
3. Connect the bipolar footswitch to the bipolar footswitch connecting socket located on the rear of the unit.

To activate the Bipolar mode, depress the pedal on the bipolar footswitch.

Setting and Recalling Memory Presets

The Bovie® IDS-210 incorporates 10 user-defined memory preset settings for easy recall of frequently used settings in all three modes.

Memory

The Memory feature allows the Bovie® IDS-210 (unit) to display the last selected Preset when the generator is turned on. When activated by the handpiece or footswitch, the unit will operate in that particular mode and power setting.

The small red blinking dot in the lower right hand corner of the Presets display lets the user know that the Preset values have been adjusted.

All new settings must be saved as a Preset to be available at startup or as a Preset selection (0 through 9) when using the unit.

Memory Function Overview

- The unit powers up with the last selected preset (0-9).
- Mode (Cut and Coag) membrane switches are disabled during activation.
- Blend amount control buttons are disabled during activation.
- Recall and Set membrane switches are disabled during activation.
- While operating the unit outside of a user-defined preset (small red dot will be blinking in lower right corner of the Preset display as an indicator), the unit temporarily store the power setting for the activated mode (Cut, Coag, or Bipolar). This temporary power setting is available until either the unit is reset, a preset is selected, or the power setting for the mode in use is adjusted and the unit is again activated.
- Presets only store one Cut mode (Cut I or Cut II, or Blend) and power setting, one Blend level (if applicable), one Coag mode (Coag or Fulguration) and powersetting, and Bipolar power setting. When storing, only the information displayed in the display windows will be saved to the unit's memory.

Setting and Recalling Presets

1. Select the desired preset (0-9) by pressing the Recall button.
2. Select the desired mode to be stored by pressing one of the mode membrane switches (Cut or Coag).
3. Select the desired power to be stored by using the power output up and down membrane switches.
4. Once all of the settings are selected, depress and hold the Presets Set button for 3 seconds. To indicate the settings have been stored, the Presets Memory Number (0-9) will blink.
5. To recall a Preset, simply press the Recall button to toggle through all of the presets.

NOTICE:

A small red dot blinking in the lower left corner of the Presets indicator display indicates that the unit is not presently set to a user-defined preset.

Activating the Unit

When you turn on your unit remember the following features:

The Bovie® IDS-210 will power up to the last selected preset.

To have a setting selection available at startup or to be one of the 10 user-defined presets, the adjustment to the mode and/or power settings must be saved by pressing the Set button on the Presets display panel.

1. Monopolar Cut - select the mode of operation for Cut: Cut I or Cut II, then select the desired Cut power settings by pressing the up and down buttons next to the Cut power output display.
2. Monopolar Blend - select the Blend mode of operation, then select the desired Blend power settings by pressing the up and down buttons next to the Cut power output display. Next, vary the blend setting by pressing the up and down buttons next to the blend amount indicator graph.
3. Monopolar Coag - select the mode of operation for coagulation: Pinpoint Coag or Fulguration, then select the coagulation power settings by pressing the up and down buttons next to the Coag power output display.
4. Bipolar - adjust the Bipolar power settings by pressing the up and down buttons next to the Bipolar power output display.

5. Activate the generator by pressing the appropriate button on the handpiece or pedal on the footswitch.
6. During activation, the activated mode can be adjusted up and or down a maximum of four steps. Refer to Section 7 for power increments.

NOTICE:

Monopolar and bipolar footswitching operations are controlled by independent foot controls.

TROUBLESHOOTING

This section includes unit verification checks and error code descriptions including actions to take to resolve them.

TECHNICAL VERIFICATION CHECKS

Follow these steps to check the functionality of the Bovie® IDS-210.

Start-up Verification

Upon start-up, the Bovie® IDS-210 should display the following:

All LEDs and seven-segment displays will illuminate “8’s” for approximately 1 to 2 seconds. The display will indicate the last preset setting, and its relevant mode and power level settings.

If the display does not illuminate or indicate the proper information, verify that the power cord is properly attached to the power receptacle.

If the display responds positively, proceed to footswitch verification.

Monopolar and Bipolar Footswitch Verification

The monopolar and bipolar footswitch indicators should light only when the proper footswitch is connected to the rear of the unit.

If the display does not illuminate or indicate the proper information, verify that the power cord is properly attached to the power receptacle.

Mode Selection and Indicators

Each power setting from zero to the maximum for that mode must be present and adjust up or down without any missed numbers. Verify by adjusting each mode to an increased power. Refer to the list below for power increments:

Monopolar Cut/Coag. Increments:

- 1 Watt Increments from 0 – 49 Watts
- 2 Watt Increments from 50 - 100 Watts
- 5 Watt Increments from 105 – 200 Watts

Bipolar Increments:

- 1 Watt Increments from 0 – 50 Watts
- 2 Watt Increments from 52 – 80 Watts

Each segment on the Blend bar must illuminate and move up or down without any missed segments. Verify by pressing the Blend amount control button on the front of the unit.

Indicators

Refer to the table on the next page that specifies each mode and its corresponding LED color.

The amber Cut LED illuminates when either the Cut I, Cut II, and Blend modes are activated, a blue Coag LED illuminates when either the Pinpoint Coag or Fulguration Coag modes are activated and a blue Bipolar LED illuminates when the Bipolar mode is activated.

1. Verify that when the unit is turned on that all the LEDs illuminate and are the correct color.
2. Verify that all the segments on the blend display can be turned on and off using the arrow keys.
3. Verify that all the output modes can be selected and that the appropriate LEDs illuminate.
4. Verify that the monopolar footswitch LED illuminates when a monopolar footswitch is connected to the monopolar footswitch receptacles on the back of the unit.
5. Verify that the bipolar footswitch LED illuminates when a bipolar footswitch is connected to the bipolar footswitch jack on the back of the unit.

The following table specifies each mode and its corresponding LED color.

Mode	LED Color
Cut I	Green
Cut II	Green
Blend Modes	Green
Pinpoint Coagulation	Green
Spray Coagulation	Green
Gentle Coagulation	Green
Bipolar Modes (Macro, Micro, Standard)	Green
Cut Activation	Yellow
Coag. Activation	Blue
Bipolar Activation	Blue
Blend Bar	Green Segments (10)
Power	Green
Auto Bipolar	Green
Presets	Green
Single Pad	Green
Split Pad	Green
Alarm	Red

RECOMMENDED EQUIPMENT FOR TROUBLESHOOTING

The following equipment enables you to troubleshoot and inspect the Bovie® IDS-210.

- Digital multimeter with leads
- Electrosurgical analyzer or a true RMS voltmeter such as a Fluke 8920A
- Wideband current transformer such as a Pearson 4100
- Non-inductive RF load resistors 200 ohms, 500 ohms, 800 ohms, 1000 ohms (minimum 150 watts)
- Oscilloscope (dual channel) at 100 MHz
- Oscilloscope probes, (2) 10X and 1000X
- Bovie footswitches (monopolar, bipolar)
- Monopolar instruments (handswitch and footswitch)
- Bovie cable
- Standard technician's tool kit
- Return electrode cable
- Miscellaneous test leads and cables

TROUBLESHOOTING THE BOVIE® IDS-210

If the generator is not functioning properly, use the information in this section to perform the following activities:

- Identify and correct the malfunction.
- If an error code was displayed, take the appropriate action(s) to correct the error condition.

Inspecting the Generator

If the Bovie® IDS-210 malfunctions, check for obvious conditions that may have caused the problem.

1. Check the generator for visible signs of physical damage.
2. Verify that all accessory cords are properly connected.
3. Check the power cord. Replace the power cord if you find exposed wires, cracks, frayed insulation, or a damaged connector.
4. Check fuses. Refer to Section 5.
5. Replace fuses if necessary. Refer to Fuse Replacement in Section 5.

Inspecting the Receptacles

Equipment required:

- Bovie footswitches (monopolar, bipolar)
- Bipolar cable
- Monopolar instruments (handswitch and footswitch)
- Return electrode cable

Bipolar procedure:

1. Turn off the generator.
2. Disconnect the power cord.
3. Check the footswitch receptacles on the rear of the unit for obvious signs of obstruction and damage.
4. Check for a secure fit by inserting the footswitch connectors into footswitch receptacles.
If the footswitch receptacles are damaged, replace the footswitch connector assembly.
5. Check the bipolar receptacle on the front of the unit for obstruction or damage.
6. Insert a bipolar cable into the bipolar receptacle on the front of the unit. Verify a secure fit.
If the bipolar receptacle is damaged, replace the bipolar connector assembly.

Monopolar procedure:

1. Turn off the generator.
2. Disconnect the power cord.
3. Check the monopolar handpiece receptacle on the front of the unit for obstruction or damage.
4. Insert a handswitching pencil into the monopolar handpiece receptacle on the front of the unit. Verify a secure fit.
If the monopolar handpiece receptacle is damaged, replace the monopolar handpiece assembly.
5. Check the monopolar foot controlled receptacle on the front of the unit for obstruction or damage.

6. Insert a monopolar foot controlled handpiece into the monopolar foot control receptacle on the front of the unit. Verify a secure fit. If the monopolar foot controlled receptacle is damaged, replace the connector assembly.
7. Check the Return Electrode receptacle on the front of the unit for a broken pin or an obstruction.
8. Insert a return electrode cable into the return electrode receptacle. Verify a secure fit. If the return electrode receptacle on the front of the unit is damaged, replace the return electrode receptacle assembly.

Refer to your User's Guide, Section 3, Confirming Modes, to verify the receptacles and the accessories connected to them are functioning properly.

Inspecting Internal Components

CAUTIONS:

The generator contains electrostatic-sensitive (ESS) components. When repairing the generator, work at a static-control workstation.

Wear a grounding strap when handling electrostatic-sensitive components.

Handle circuit boards by their nonconductive edges.

Use an anti-static container for transport of electrostatic-sensitive components and circuit boards.

To inspect the internal components, follow this procedure:

1. Remove the six screws that secure the cover to the chassis.
2. Lift the cover off the chassis. Save the cover and screws for later reinstallation.
3. Disconnect ground cable from the top cover.
4. Visually inspect and verify that all connectors are firmly seated and locked into the connectors.
5. Inspect each board for damaged components, wires, cracks and corrosion.
6. Reinstall the cover by connecting the ground cable to the cover, positioning the cover over the chassis, and securing

The Bovie® IDS-210 includes automatic self-diagnostics. If the diagnostics detect an error or fault, the system displays an appropriate code, sounds an audible tone, and deactivates the unit output power.

The following tables list the codes, describes the errors or faults, and recommends actions from what is listed below to take to resolve the error or fault.

All error codes are displayed in the Bipolar display. If the unit displays any other error code, it requires service. Power off unit and call 888-364-7004.

NOTICE:
If the unit does not power on and nothing is displayed in the Bipolar display, check fuses as described in Section 5 of this guide.

SYSTEM FAULT CODE MESSAGES

Fault messages (F) indicate improper unit setup or faulty accessories.

Fault Code	Description	Recommended Action
F1	Cut button on handpiece 1 is depressed during power up.	<p>1. If the fault code appears, disconnect all accessories. Turn off, then turn on the generator again.</p> <p>2. If the problem persists, replace the handpiece or footswitch and repeat the restart.</p> <p>3. If the fault code reappears, record the number and contact Bovie® customer service at 888-364-7004.</p>
F2	Coag button on handpiece 1 is depressed during power up.	
F3	Cut button on handpiece 2 is depressed during power up.	
F4	Coag button on handpiece 2 is depressed during power up.	
F5	Cut pedal on monopolar footswitch is depressed during power up.	
F6	Coag pedal on monopolar footswitch is depressed during power up.	
F7	Bipolar pedal on bipolar footswitch is depressed during power up.	
F8	Bipolar activation button is depressed during power up.	
F9	Simultaneous activation from a footswitch or handpiece or any combination. <i>This does not apply to activation of the spray mode.</i>	
F10	Activation request of a monopolar or bipolar footswitch when no footswitch connection or Bovie® approved footswitch is detected.	
F11	Activation request of a monopolar handpiece 1 when no monopolar footcontrolled handpiece connected to the monopolar handpiece connector 1.	

SYSTEM FATAL ERROR MESSAGES

Error messages (E) indicate internal problems with the unit.

Error Code	Description	Recommended Action
E1	Output Current out of Specification, Digital Check	<ol style="list-style-type: none">1. Turn the unit off (for Temperature Errors, let unit cool for 20 minutes).2. Turn the unit on.3. If the error code reappears, record the number and contact Bovie® customer service at 888-364-7004.
E4	DC Voltage Error	
E5	Temperature Sense Error 1	
E6	Temperature Sense Error 2	
E7	NEM / Autobipolar Error	
E8	NEM Calibration Error	
E9	A/D Error	
E10	Watch Dog Error	
E11	Relay Board Cable Sense Error	
E12	Dosage Error	

CORRECTING COMMON PROBLEMS

If a solution is not readily apparent, use the table below to help identify and correct specific malfunctions. After you correct the malfunction, verify that the generator successfully completes the self-test.

Situation	Possible Cause	Recommended Action
Generator is on and the accessory is activated, but the generator does not deliver output power.	<p>An error condition exists</p> <p>Main board malfunction</p>	<p>1. Check the bipolar displays for an error code number. 2. Note the number and refer to the error codes descriptions in this section.</p> <p>1. Check and connect all connections from main board to display board. 2. Replace main board.</p>
Footswitch will not activate output.	<p>Malfunctioning or damaged footswitch receptacle</p> <p>Footswitch activation signal lost on main board.</p> <p>Sensing circuit malfunction</p>	<p>Replace the Footswitch connector assembly.</p> <p>1. Check/connect loose cable. 2. Replace the main board.</p> <p>Replace the display board.</p>
Continuous monitor Interference	<p>Faulty chassis-to-ground connections</p> <p>Electrical equipment is grounded to different objects rather than a common ground.</p> <p>The generator may respond to the resulting voltage differences between grounded objects.</p> <p>Malfunctioning monitor</p>	<p>1. Check and correct the chassis ground connections for the monitor and, if applicable, for the generator. 2. Check other electrical equipment in the room for defective grounds.</p> <p>Plug all electrical equipment into line power at the same location.</p> <p>Replace the monitor.</p>
Interference with other devices only when generator is active	<p>Metal-to-metal sparking</p> <p>High settings used for fulguration</p>	<p>Check all connections to the generator, patient return electrode, and accessories.</p> <p>Use lower power settings for fulguration or select the Coagulation mode.</p>

Situation	Possible Cause	Recommended Action
Generator does not respond when turned on.	<p>Disconnected power cord, faulty wall receptacle, or faulty power cord.</p> <p>Fuses blown</p> <p>Loose or disconnected internal cables</p> <p>Faulty power switch</p> <p>Faulty power supply</p>	<p>1. Check power cord connections (generator and wall receptacle).</p> <p>2. Connect the power cord to a functional wall receptacle. If necessary, replace the cord.</p> <p>1. Check fuses. If necessary, replace fuse(s).</p> <p>2. If a problem persists, use a backup generator.</p> <p>Check all internal connections.</p> <p>Replace the power switch.</p> <p>Replace power supply.</p>
Generator is on, but will not activate.	<p>An alarm condition exists.</p> <p>Loose or disconnected internal cables</p> <p>Main board malfunction</p> <p>Display board malfunction</p> <p>Relay board malfunction</p> <p>Disconnected or faulty handpiece</p> <p>Disconnected or faulty footswitch(s)</p>	<p>Check the display for an error code. Note the number and refer to the Error Code list.</p> <p>Check and connect all internal cables.</p> <p>1. Check and connect all connections from main board to display board.</p> <p>2. Replace main board.</p> <p>Replace the display board.</p> <p>Replace the relay board.</p> <p>Check or replace handpiece.</p> <p>Check or connect faulty footswitch.</p>
Activation and/or alarm tones do not sound; speaker is malfunctioning.	<p>Loose or disconnected cable between main board and speaker board</p> <p>Main board malfunction</p> <p>Display board malfunction</p> <p>Speaker board malfunction</p>	<p>Check/connect all connections from the speaker board to the main board.</p> <p>1. Check/connect all connections from the main board to the display board.</p> <p>2. Replace the main board.</p> <p>Replace the display board.</p> <p>Replace the speaker board.</p>

Situation	Possible Cause	Recommended Action
Interference with other devices only when generator is activated	<p>Electrically inconsistent ground wires in the operating room</p> <p>If interference continues when the generator is activated, the monitor is responding to radiated frequencies.</p>	<p>Verify that all ground wires are as short as possible and go to the same grounded metal.</p> <p>Check with the manufacturer of the monitor.</p> <p>Some manufacturers offer choke filters for use in monitor leads.</p> <p>The filters reduce interference when the generator is activated and minimize the potential for an electrosurgical burn at the site of the monitor electrode.</p>
Pacemaker interference	<p>Intermittent connections or metal-to-metal sparking</p> <p>Current traveling from active to return electrode during monopolar electrosurgery is passing too close to pacemaker.</p>	<ol style="list-style-type: none"> 1. Check all connections to the generator. It may be necessary to re-program the pacemaker. 1. Use bipolar instruments, if possible. If you must use a monopolar instrument, place the return electrode as close as possible to the surgical site. 2. Make sure the current path from the surgical site to the return electrode does not pass through the vicinity of the heart or the site where the pacemaker is implanted. 3. Always monitor patients with pacemakers during surgery and keep a defibrillator available. 4. Consult the pacemaker manufacturer or hospital. 5. 5. Contact the Cardiology Department for further information when use of electrosurgical appliances is planned
Abnormal neuromuscular stimulation - <i>stop surgery immediately.</i>	<p>Metal-to-metal sparking</p> <p>Can occur during coagulation</p> <p>Abnormal 50 Hz - 60 Hz leakage currents</p>	<p>Check all connections to the generator, patient plate, and active electrodes. Use a lower setting for the Fulguration mode or select the Coagulation mode.</p> <p>Inside the generator, carefully inspect for damage that may cause shorting between the AC line voltage and connected patient components.</p>
<p>Blank or confusing LED display</p> <p>Mode buttons do not operate properly when pressed.</p>	<p>Display board malfunction</p> <p>Damaged front panel overlay</p> <p>Loose or disconnected internal cable</p> <p>Power supply malfunction</p> <p>Main board malfunction</p>	<p>Replace the display board.</p> <p>Replace front panel overlay.</p> <p>Check/connect overlay cable to display board.</p> <p>Replace the power supply.</p> <p>Replace the main board.</p>

Situation	Possible Cause	Recommended Action
<p>Generator is on and the accessory is activated, but the generator does not deliver output.</p>	<p>Malfunctioning footswitch or handswitching instrument</p> <p>Power set too low</p> <p>Display board malfunction</p> <p>Main board malfunction</p> <p>Relay board malfunction</p> <p>NEM alarm</p>	<ol style="list-style-type: none"> 1. Turn off the generator. Check and correct all accessory connections. 2. Turn on the generator 3. Replace the accessory if it continues to malfunction. <p>Increase the power setting.</p> <p>Replace the display board.</p> <p>Replace the main board.</p> <p>Replace the relay board.</p> <ol style="list-style-type: none"> 1. Check/connect the Return Electrode connection to the patient and connection to the generator. 2. Replace Return Electrode

TEST POINTS

Test Point	Description	Location On PCA
TP1	+3.3V DC power supply	TOP/BOTTOM SIDE
TP2	+5V DC POWER SUPPLY	TOP/BOTTOM SIDE
TP3	+12V DC POWER SUPPLY	TOP/BOTTOM SIDE
TP4	-12V DC POWER SUPPLY	TOP/BOTTOM SIDE
TP5	DIGITAL GROUND	TOP/BOTTOM SIDE
TP6	NOT USED	N/A
TP7	NOT USED	N/A
TP8	+16V DC POWER SUPPLY	TOP/BOTTOM SIDE
TP9	GROUND FOR +16V DC	TOP/BOTTOM SIDE
TP10	COOLING FAN OUTPUT (OPTIONAL)	TOP/BOTTOM SIDE
TP11	+12VR DC POWER SUPPLY (POWER FOR THE RELAY BOARD)	TOP/BOTTOM SIDE
TP12	NOT USED	N/A
TP13	NOT USED	N/A
TP14	ACTIVATION REQUEST FOOTSWITCH-COAG	TOP/BOTTOM SIDE
TP15	ACTIVATION REQUEST FOOTSWITCH-CUT	TOP/BOTTOM SIDE
TP16	ACTIVATION REQUEST MONOPOLAR 1-CUT	TOP/BOTTOM SIDE
TP17	ACTIVATION REQUEST FOOTSWITCH-COAG	TOP/BOTTOM SIDE
TP18	BACKUP CURRENT SENSING SIGNAL 3	TOP/BOTTOM SIDE
TP19	BACKUP CURRENT SENSING SIGNAL 2 (REFERENCE)	TOP/BOTTOM SIDE
TP20	BACKUP CURRENT SENSING SIGNAL 1	TOP/BOTTOM SIDE
TP21	BACKUP VOLTAGE SENSING SIGNAL 1	TOP/BOTTOM SIDE
TP22	BACKUP VOLTAGE SENSING SIGNAL 2 (REFERENCE)	TOP/BOTTOM SIDE
TP23	BACKUP VOLTAGE SENSING SIGNAL 3	TOP/BOTTOM SIDE
TP24	MAIN VOLTAGE SENSING SIGNAL 1	TOP/BOTTOM SIDE
TP25	MAIN VOLTAGE SENSING SIGNAL 2 (REFERENCE)	TOP/BOTTOM SIDE
TP26	MAIN VOLTAGE SENSING SIGNAL 3	TOP/BOTTOM SIDE
TP27	MAIN CURRENT SENSING SIGNAL 1	TOP/BOTTOM SIDE
TP28	MAIN CURRENT SENSING SIGNAL 2 (REFERENCE)	TOP/BOTTOM SIDE
TP29	MAIN CURRENT SENSING SIGNAL 3	TOP/BOTTOM SIDE
TP30	SPI CLOCK AUTOBIPOLAR CIRCUIT	TOP/BOTTOM SIDE
TP31	SPI DATA OUT AUTOBIPOLAR CIRCUIT	TOP/BOTTOM SIDE
TP32	SPI SELECT AUTOBIPOLAR CIRCUIT	TOP/BOTTOM SIDE
TP33	AUTOBIPOLAR CLOCK GENERATOR	TOP/BOTTOM SIDE
TP34	AUTOBIPOLAR MODE SELECT	TOP/BOTTOM SIDE
TP35	AUXILIARY RELAY SWITCH	TOP/BOTTOM SIDE
TP36	VOLTAGE SENSOR SCALE	TOP/BOTTOM SIDE
TP37	CURRENT SENSOR SCALE	TOP/BOTTOM SIDE
TP38	NEUTRAL ELECTRODE MONITORING (NEM) CIRCUIT (TERMINAL 1)	TOP/BOTTOM SIDE

TEST POINTS – CONT.

Test Point	Description	Location On PCA
TP39	NEUTRAL ELECTRODE MONITORING (NEM) CIRCUIT (TERMINAL 2)	TOP/BOTTOM SIDE
TP40	1-WIRE RECEIVE (RX)	TOP/BOTTOM SIDE
TP41	1-WIRE TRANSMIT (TX)	TOP/BOTTOM SIDE
TP42	DISPLAY CONTROL - SPI DATA IN	TOP/BOTTOM SIDE
TP43	DISPLAY CONTROL -SPI DATA OUT	TOP/BOTTOM SIDE
TP44	DISPLAY CONTROL -SPI CLOCK	TOP/BOTTOM SIDE
TP45	DISPLAY CONTROL - SPI SELECT	TOP/BOTTOM SIDE
TP46	DISPLAY CONTROL - CLEAR INTERRUPT	TOP/BOTTOM SIDE
TP47	DISPLAY CONTROL- INTERRUPT	TOP/BOTTOM SIDE
TP48	DISPLAY CONTROL RESET	TOP/BOTTOM SIDE
TP49	TEMP SENSOR 2	TOP/BOTTOM SIDE
TP50	TEMP SENSOR 1	TOP/BOTTOM SIDE
TP51	POWER FACTOR CONTROL ENABLE/DISABLE	TOP/BOTTOM SIDE
TP52	1.2V DC POWER SUPPLY (FPGA CORE VOLTAGE)	TOP/BOTTOM SIDE
TP53	1-WIRE DISABLE	TOP/BOTTOM SIDE
TP54	RF DRIVER SIGNAL 1 (FPGA)	TOP/BOTTOM SIDE
TP55	RF DRIVER SIGNAL 2 (FPGA)	TOP/BOTTOM SIDE
TP56	RELAY BOARD CABLE CHECK	TOP/BOTTOM SIDE
TP57	OUTPUT STAGE PRIMARY RELAY CONTROL-CUT/COAG	TOP/BOTTOM SIDE
TP58	SMPS RANGE CONTROL	TOP/BOTTOM SIDE
TP59	OUTPUT RELAY LOWER TRAF0 WINDING CONTROL (FPGA)	TOP/BOTTOM SIDE
TP60	OUTPUT RELAY MONOPOLAR/BIPOLAR CONTROL (FPGA)	TOP/BOTTOM SIDE
TP61	OUTPUT RELAY HANDLE CONTROL (FPGA)	TOP/BOTTOM SIDE
TP62	OUTPUT RELAY FOOT CONTROL (FPGA)	TOP/BOTTOM SIDE
TP63	ENABLE/DISABLE SERIAL COMMUNICATION (OPTIONAL)	TOP/BOTTOM SIDE
TP64	SPI CLOCK CONTROL-MASTER (OPTIONAL)	TOP/BOTTOM SIDE
TP65	SPI DATA OUT CONTROL/SERIAL TX -MASTER (OPTIONAL)	TOP/BOTTOM SIDE
TP66	SPI SLAVE SELECT -MASTER (OPTIONAL)	TOP/BOTTOM SIDE
TP67	SPI CLOCK CONTROL-SLAVE (OPTIONAL)	TOP/BOTTOM SIDE
TP68	SPI DATA IN CONTROL/SERIAL TX -SLAVE(OPTIONAL)	TOP/BOTTOM SIDE
TP69	SPI SLAVE SELECT -SLAVE (OPTIONAL)	TOP/BOTTOM SIDE
TP70	ACTIVATION REQUEST MONOPOLAR 2-COAG	TOP/BOTTOM SIDE
TP71	ACTIVATION REQUEST MONOPOLAR 2-CUT	TOP/BOTTOM SIDE
TP72	MONOPOLAR FOOTSWITCH RECOGNITION REQUEST	TOP/BOTTOM SIDE
TP73	BIPOLAR FOOTSWITCH RECOGNITION REQUEST	TOP/BOTTOM SIDE
TP74	ACTIVATION REQUEST BIPOLAR FOOTSWITCH	TOP/BOTTOM SIDE
TP75	NEGATIVE VOLTAGE RECTIFIER OUTPUT (NON-REGULATED)	TOP/BOTTOM SIDE
TP76	NOT USED	N/A
TP77*	DRAIN OUTPUT OF VIPER53 - LOW POWER SPMS	TOP/BOTTOM SIDE

TEST POINTS – CONT.

Test Point	Description	Location On PCA
TP78	+6V TR1 WINDING VOLTAGE	TOP/BOTTOM SIDE
TP79**	PRIMARY (MAINS) GROUND-LOW POWER SPMS	TOP/BOTTOM SIDE
TP80**	POWER FACTOR CONTROL Q3 DRAIN VOLTAGE	TOP/BOTTOM SIDE
TP81**	DC POWER SUPPLY OF PFC CONTROLLER (+14V)	TOP/BOTTOM SIDE
TP82**	PFC OUTPUT VOLTAGE +380V DC	TOP/BOTTOM SIDE
TP83	NOT USED	N/A
TP84**	PFC – GROUND	TOP/BOTTOM SIDE
TP85**	PFC – GROUND	TOP/BOTTOM SIDE
TP86	SMPS DRIVER SIGNAL	TOP/BOTTOM SIDE
TP87	SMPS OUTPUT - VOLTAGE 16-232V	TOP/BOTTOM SIDE
TP88	DIGITAL GROUND	TOP/BOTTOM SIDE
TP89*, **	PFC - GROUND (SMPS PRIMARY (MAINS) SECTION)	TOP SIDE ONLY
TP90	SMPS OUTPUT -GROUND	TOP/BOTTOM SIDE
TP91	SMPS DRIVER 1 SIGNAL	TOP/BOTTOM SIDE
TP92	RF DRIVER U18 POWER SUPPLY (+12V DC)	TOP/BOTTOM SIDE
TP93	POWER GENERATOR DC VOLTAGE (SMPS OUTPUT VOLTAGE)	TOP/BOTTOM SIDE
TP94	RF DRIVER SIGNAL (U18 INPUT)	TOP/BOTTOM SIDE
TP95*	DIGITAL GROUND (DRIVER)	TOP SIDE ONLY
TP96	DRAIN VT5 POWER GENERATOR	TOP/BOTTOM SIDE
TP97	RF DRIVER U19 POWER SUPPLY (+12V DC)	TOP/BOTTOM SIDE
TP98	VT5 GATE VOLTAGE -POWER GENERATOR	TOP/BOTTOM SIDE
TP99	RF DRIVER SIGNAL (U19 INPUT)	TOP/BOTTOM SIDE
TP100	VT7 GATE VOLTAGE -POWER GENERATOR	TOP/BOTTOM SIDE
TP101	DRAIN VT7 POWER GENERATOR	TOP/BOTTOM SIDE
TP102	DIGITAL GROUND (DRIVER)	TOP/BOTTOM SIDE
TP103	RF DRIVER U20 POWER SUPPLY (+12V DC)- RF DAMPING	TOP/BOTTOM SIDE
TP104	POWER GENERATOR GROUND (SMPS OUTPUT GROUND)	TOP/BOTTOM SIDE
TP105*	POWER GENERATOR GROUND (SMPS OUTPUT GROUND)	TOP SIDE ONLY
TP106	RF DRIVER FOR POWER GENERATOR RF DAMPING	TOP/BOTTOM SIDE
TP107	GATE VT6 - POWER GENERATOR RF DAMPING CONTROL	TOP/BOTTOM SIDE
TP108	NOT USED	N/A
TP109	NOT USED	N/A
TP110	NOT USED	N/A
TP111	FOOTCONTROL PLUGGED-IN RECOGNITION REQUEST	TOP/BOTTOM SIDE
NOTES: * - SINGLE LOOP TEST POINTS FOR PROBE ATTACHMENT, ALL OTHER TEST POINTS ARE TEST PCB PADS ** -ELECTRIC SHOCK HAZARD! -THE TEST POINTS IN BOLD ARE LOCATED IN THE MAINS CIRCUIT (100-240V AC), WHERE DANGEROUS HIGH VOLTAGES ARE PRESENT! USE EXTREME CAUTION AND ISOLATED FROM EARTH INSTRUMENTS (FOR INSTANCE ISOLATION MAINS TRANSFORMERS) FOR SIGNAL MEASUREMENTS IN THIS AREA!		

REPAIR POLICY AND PROCEDURES

Refer to this section for information on:

- Responsibility of the Manufacturer
- Returning the Generator for Service

RESPONSIBILITY OF THE MANUFACTURER

Bovie® is responsible for the safety, reliability, and performance of the generator only under the following circumstances:

- The user has followed the Installation and Setup Procedures in this User's Guide.
- Persons authorized by Aspen Surgical Products performed assembly operation, readjustments, modifications, or repairs.
- The electrical installation of the relevant room complies with local codes and regulatory requirements, such as IEC and BSI.
- Equipment use is in accordance with the Aspen Surgical Products instructions for use.

Please note that infected medical devices must be disposed of as medical/biohazard waste and cannot be included in used electronic equipment disposal/recycling programs. In addition, certain electronic products must be returned directly to Aspen Surgical Products. Contact your Aspen Surgical Products representative for return instructions.

For warranty information, refer to Appendix B - Warranty.

RETURNING THE GENERATOR FOR SERVICE

Before you return the generator, call your Aspen Surgical Products representative for assistance. If instructed to send the generator to Aspen Surgical Products, first obtain a Returned Goods Authorization Number. Then, clean the Generator and package securely to ensure proper protection of the unit. So as to aid in the processing of the unit, please be sure to include a reference to the Bovie® Return Goods Authorization Number on the outside of the box and ship directly to Aspen Surgical Products.

Step 1 – Obtain a Returned Goods Authorization Number

Call the Aspen Surgical Products Customer Service Center to obtain a Returned Goods Authorization Number. Have the following information ready when you call:

- Hospital / clinic name / customer number
- Telephone number/fax number
- Department / address, city, state, and zip code
- Model number / Serial number
- Description of the problem
- Type of repair to be done
- P.O. number

Step 2 – Clean the Generator

WARNING:

Electric Shock Hazard - Always turn off and unplug the generator before cleaning.

NOTICE:

Do not clean the generator with abrasive cleaning or disinfectant compounds, solvents, or other materials that could scratch the panels or damage the generator.

- A. Turn off the generator, and unplug the power cord from the wall outlet.
- B. Thoroughly wipe all surfaces of the generator and power cord with a mild cleaning solution or disinfectant and a damp cloth. Follow the procedures approved by your institution or use a validated infection control procedure. Do not allow fluids to enter the chassis. You cannot sterilize the generator.

Step 3 – Ship the Generator

- A. Attach a tag to the generator that includes the Returned Goods Authorization Number and the information (hospital, phone number, etc.) listed in Step 1 – Obtain a Returned Goods Authorization Number.
- B. Be sure the generator is completely dry before you pack it for shipment. Although the preference is to have the Generator repackaged using its original packaging, Bovie understands that this may not always be possible. If necessary, contact Customer Service for the proper packaging to ship the unit. Please be sure to include a reference of the Bovie Return Goods Authorization Number on the outside of the box/container.
- C. Ship the generator, prepaid, to the address given to you by the Aspen Surgical Products Service Center.



WARRANTY

Aspen Surgical Products, warrants each product manufactured by it to be free from defects in material and workmanship under normal use and service for the period(s) set forth below.

Aspen Surgical Products obligation under this warranty is limited to the repair or replacement, at its sole option, of any product, or part thereof, which has been returned to it or its Distributor within the applicable time period shown below after delivery of the product to the original purchaser, and which examination discloses, to Aspen Surgical Products satisfaction, that the product is indeed, defective.

This warranty does not apply to any product, or part thereof, which has been repaired or altered outside Aspen Surgical Products

Corporation's factory in a way so as, in Aspen Surgical Products judgment, to affect its stability or reliability, or which has been subjected to misuse, neglect, or accident.

The warranty periods for Aspen Surgical Products are as follows:

- Electrosurgical Generators: Four years from date of shipment
- Mounting Fixtures (all models): Two years from date of shipment
- Footswitches (all models): One year from date of shipment
- Patient Return Electrodes: Shelf life only as stated on packaging
- Sterile Single Use Accessories: Only as stated on packaging
- Handpiece: Only as stated on packaging

This warranty is in lieu of all other warranties, express or implied, including without limitation, the warranties of merchantability and fitness for a particular purpose, and of all other obligations or liabilities on the part of Aspen Surgical Products.

Aspen Surgical Products neither assumes nor authorizes any other person to assume for it any other liability in connection with the sale or use of any of Aspen Surgical Products.

Notwithstanding any other provision herein or in any other document or communication, Aspen Surgical Products liability with respect to this agreement and products sold hereunder shall be limited to the aggregate purchase price for the goods sold by Bovie Medical Corporation to the customer.

Aspen Surgical Products disclaims any liability hereunder or elsewhere in connection with the sale of this product, for indirect or consequential damages.

This warranty and the rights and obligations hereunder shall be construed under and governed by the laws of the State of Michigan, USA.

The sole forum for resolving disputes arising under or relating in any way to this warranty is the District Court of the County of Kent, State of Michigan, USA.

Aspen Surgical Products, its dealers, and representatives reserve the right to make changes in equipment built and/or sold by them at any time without incurring any obligation to make the same or similar changes on equipment previously built and/or sold by them.



BOARD DRAWINGS, SCHEMATICS, & ASSEMBLIES

HOW TO ORDER PARTS FROM ASPEN SURGICAL PRODUCTS

Once you have determined what parts you need from the drawings and Bill of Materials, contact our Technical Service Department by calling (800) 537-2790 or dialing +1-888-364-7004 for international calls.

Our trained staff will verify the part numbers and arrange immediate delivery. The Technical Service Department can relay cost information, determine parts availability, and suggest any assembly updates available.

BOVIE® IDS-210 DESIGN BREAKDOWN AND DRAWING REFERENCE

PCB ASSEMBLIES	
P/N	Description
20-160-002	IDS-210/A2350 Relay Board Top
20-159-002	IDS-210/A2350 Main PCB Assembly
20-161-001	IDS-210/A2350 PCB Assembly Display
20-045-003	IDS-210/A2350 PCB Assembly Speaker
20-166-002	IDS-210/A2350 PCB Assembly Power Supply
Enclosure	
P/N	Description
10-180-001	IDS-210/A2350 Relay Board Top
10-181-001	IDS-210/A2350 Bottom Right Frame Rail
10-182-001	IDS-210/A2350 Top Left Frame Rail
10-183-001	IDS-210/A2350 Top Right Frame Rail
10-172-001	IDS-210 Bottom Plate
10-176-001	Main PCB Support IDS-210 Gas Hybrid
10-173-001	IDS-210/A2350 Top Cover
10-196-001	EMI Filter Mounting Plate
10-174-001	IDS-210/A2350 Back Plate
CABLES	
P/N	Description
21-078-001	24PIN Cable Assembly
25-101-001	Cable Assembly Female 0.050"x0.05" 20P 6.00"
25-102-002	Cable Assembly Female 0.050"x0.050" 10P 3.00"
25-111-001	Cable Assembly A1450 Relay/Main 120mm GRN
25-111-002	Cable Assembly A1450 Relay/Main 120mm RED
25-124-001	Cable Assembly Monopolar Footswitch Control
25-125-001	Cable Assembly Bipolar Footswitch Control
25-126-001	Cable Assembly Relay Output IDS-210/A2350

CABLES	
P/N	Description
25-127-001	Cable Ground 10" Long
25-127-002	Cable Ground 13" Long
25-133-001	Cable EMI Filters Connection
21-061-002	Cable Ground 6" Long Flagged ¼
25-123-001	Cable Assembly Power Harness
MISC.	
P/N	Description
11-161-001	Gasket 0.021" Thick Urethane Foam
07-215-001	Switch Non-Illuminated Round Rocker
15-344-001	Overlay Display A2350
15-345-001	Overlay Front Connector A2350
04-148-035	Stud, Ground DIN 42801 35mm L

IDS-210 DRAWING AND SCHEMATIC PACKAGE

Following tri-folds.

NOTICE:

The title blocks of the following drawings and schematics refer to the generator series titled IDS-310 and J-Plasma Hybrid. The Bovie® IDS-210 is part of this series.

Schematic 1 Main Top

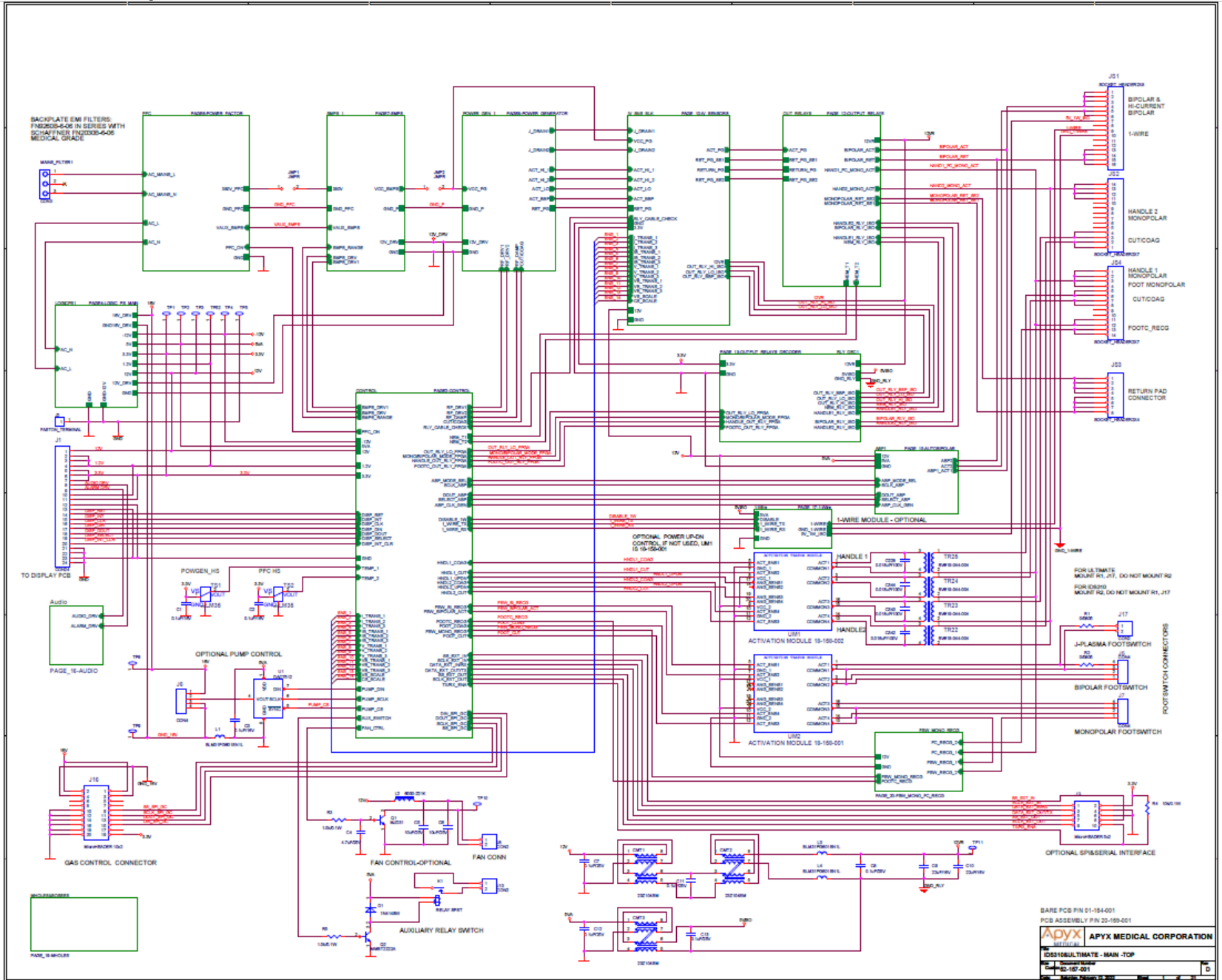

Schematic 2 Control

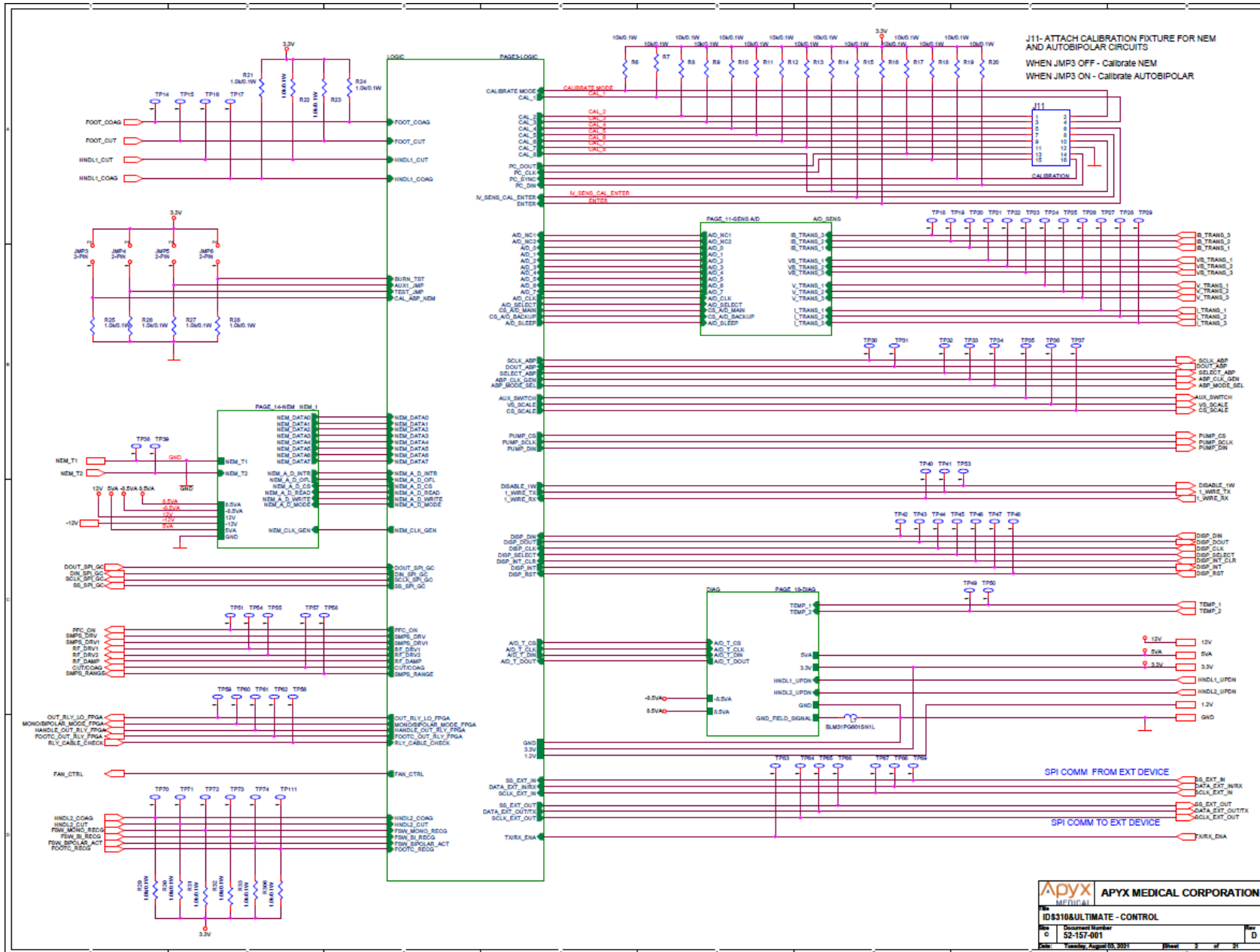

APYX MEDICAL CORPORATION

IDS310&ULTIMATE - CONTROL

Document Number: 52-157-001

Version: 1.0

Date: Tuesday, August 25, 2015

Page: 3 of 3

Schematic 3 Cyclone II FPGA Logic

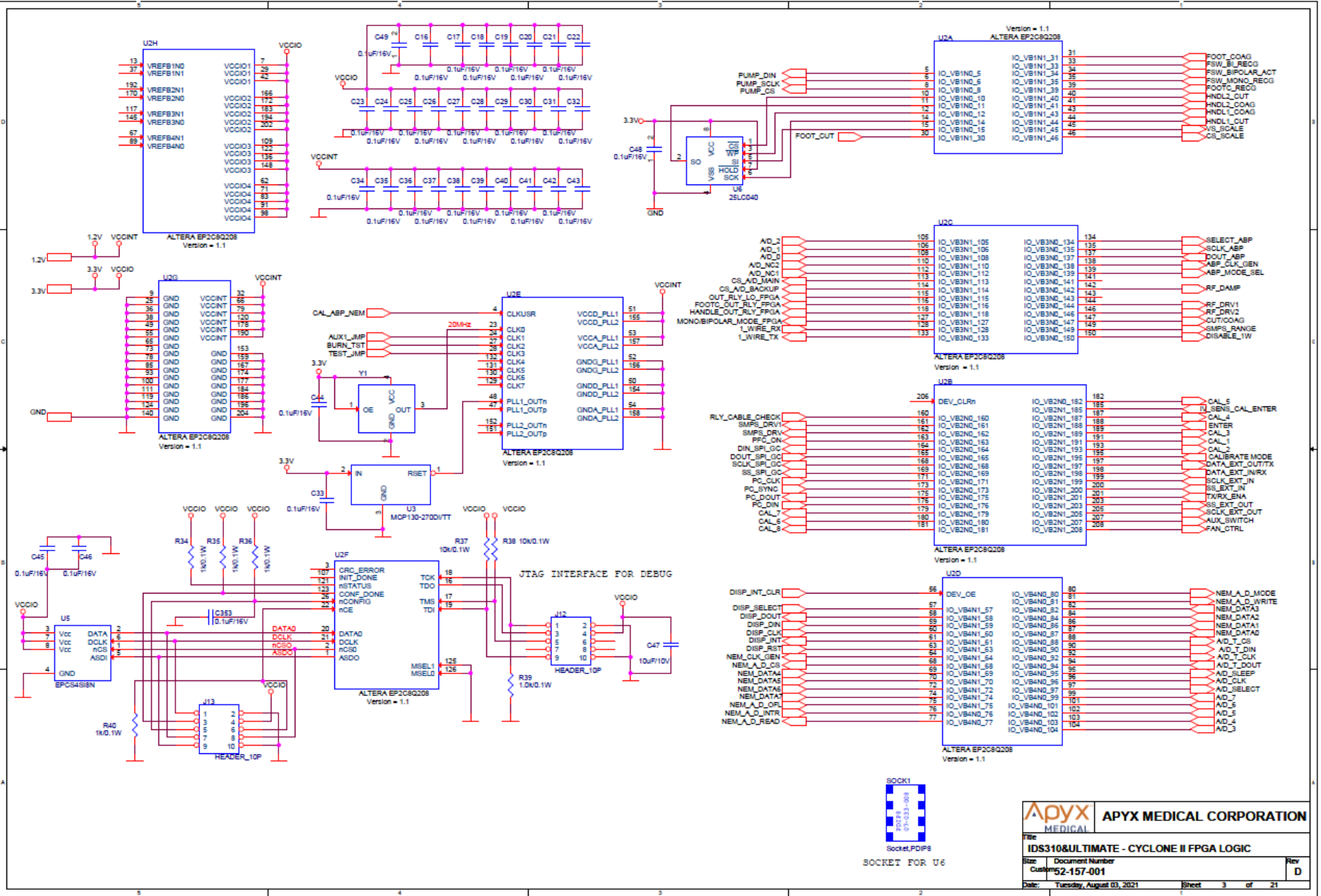

APYX MEDICAL CORPORATION
APYX MEDICAL

File: **IDS310&ULTIMATE - CYCLONE II FPGA LOGIC**
 Size: **52-157-001**
 Date: **Tuesday, August 03, 2021**

Sheet **3** of **21**

Schematic 4 Logic PS Main

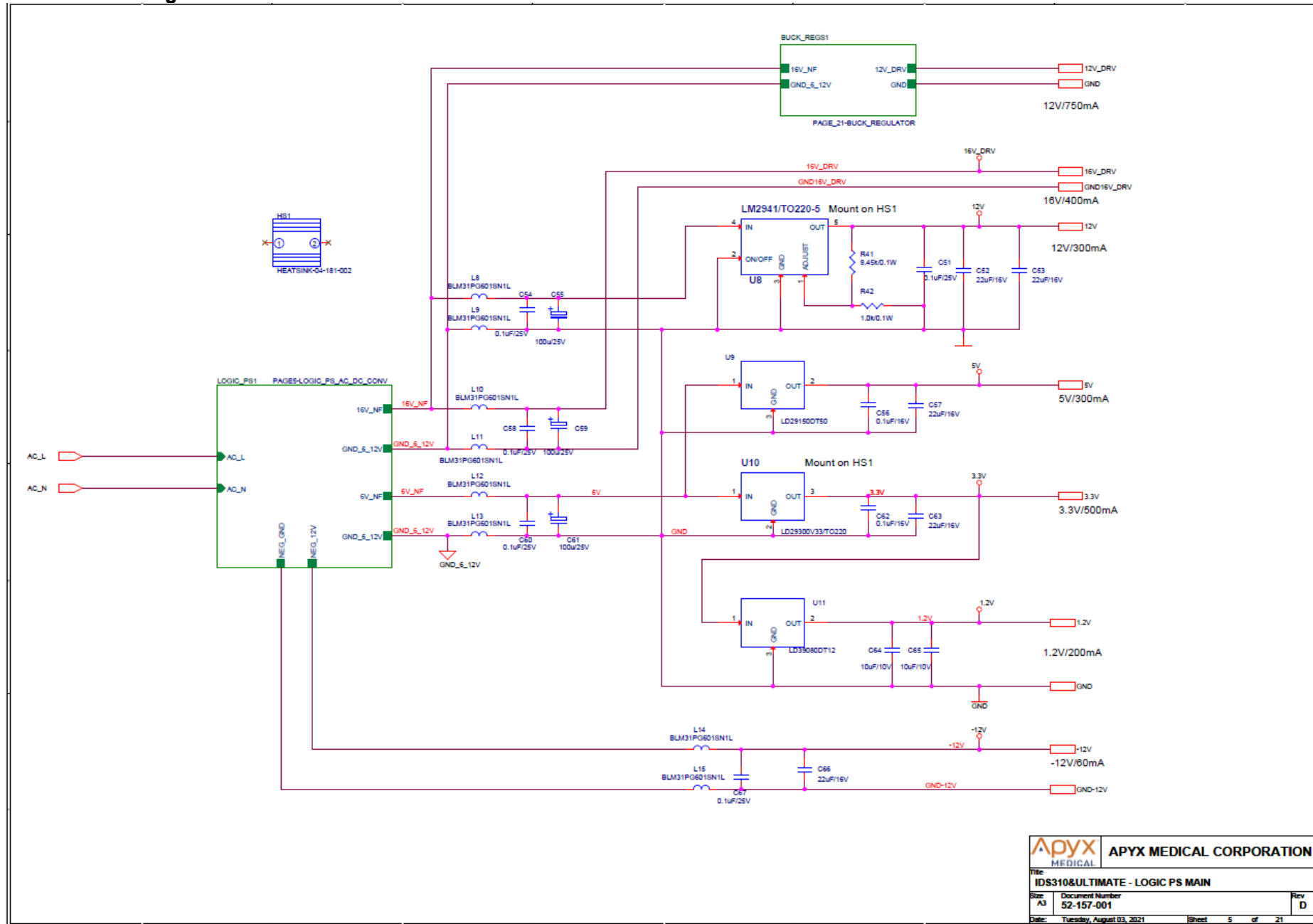

Apyx MEDICAL		APYX MEDICAL CORPORATION	
Title: IDS310&ULTIMATE - LOGIC PS MAIN			
Size: A3	Document Number: 52-157-001	Rev: D	
Date: Tuesday, August 03, 2021	Sheet: 5	of: 21	

Schematic 5 Logic SMPS, AC/DC

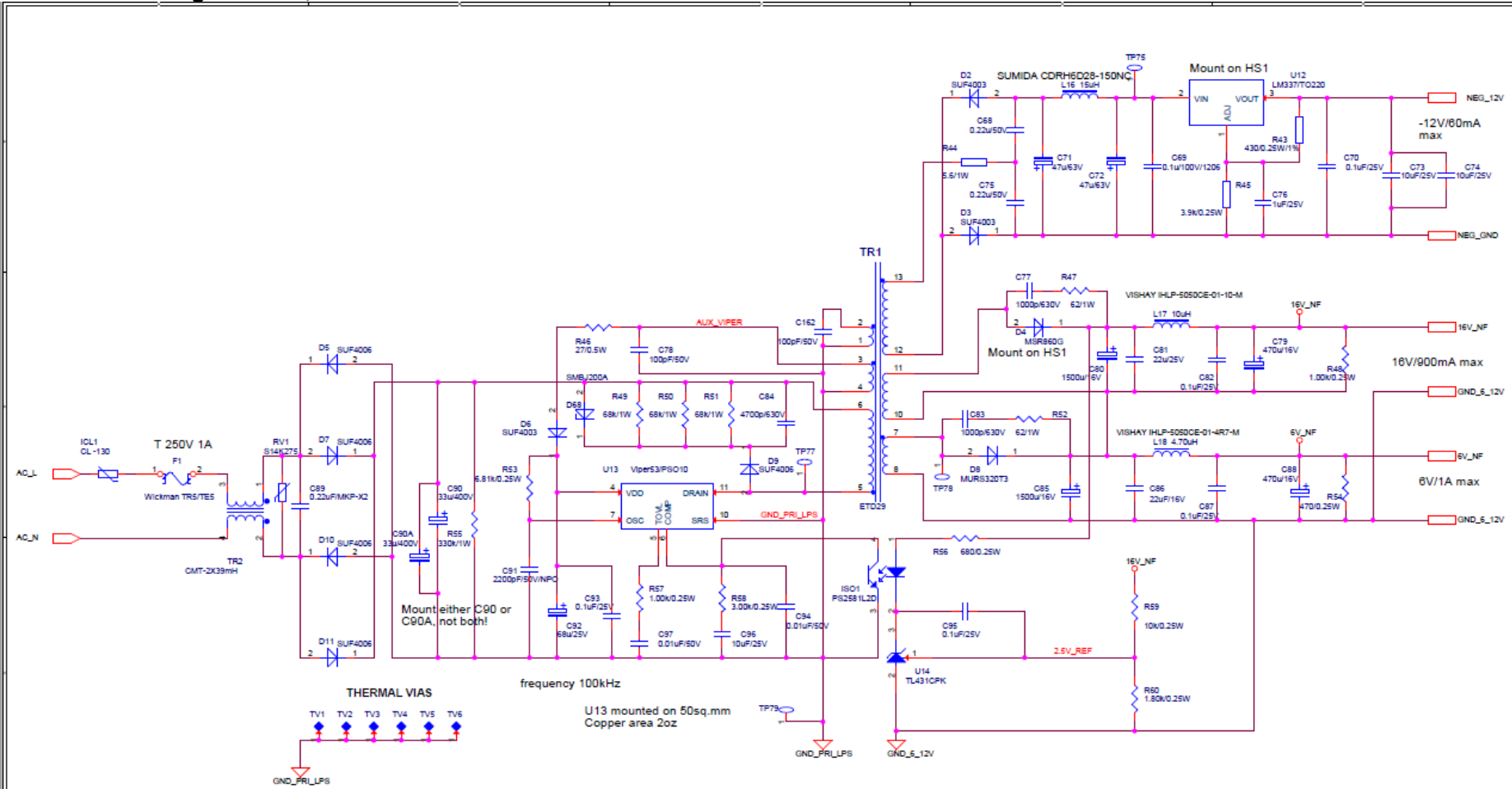

REMARKS

1. D4, U12 MOUNTED ON HS1-ISOLATED
2. ALL ELECTROLYTIC CAPACITORS ARE LOW ESR TYPE FK-PANASONIC. C72, C73 - THROUGH HOLE LOW ESR, HIGH RIPPLE CURRENT
3. R49, R50, R51 ARE STACKPOLE ELECTRONICS INC. TYPE RVC 2512 68K 5% A
4. R55 IS STACKPOLE ELECTRONICS INC. TYPE RVC 2512 330K 5% A
5. C90A IS 88UF, 400V, 20%, RADIAL (PN: 02-350-880). ONLY FOR BOVIE ULTIMATE!!!

APYX MEDICAL CORPORATION	
Title: IDS310&ULTIMATE - LOGIC SMPS, AC/DC	
Size: A3	Document Number: 52-157-001
Date: Tuesday, August 03, 2021	Sheet: 5 of 21

Schematic 6 PFC Block

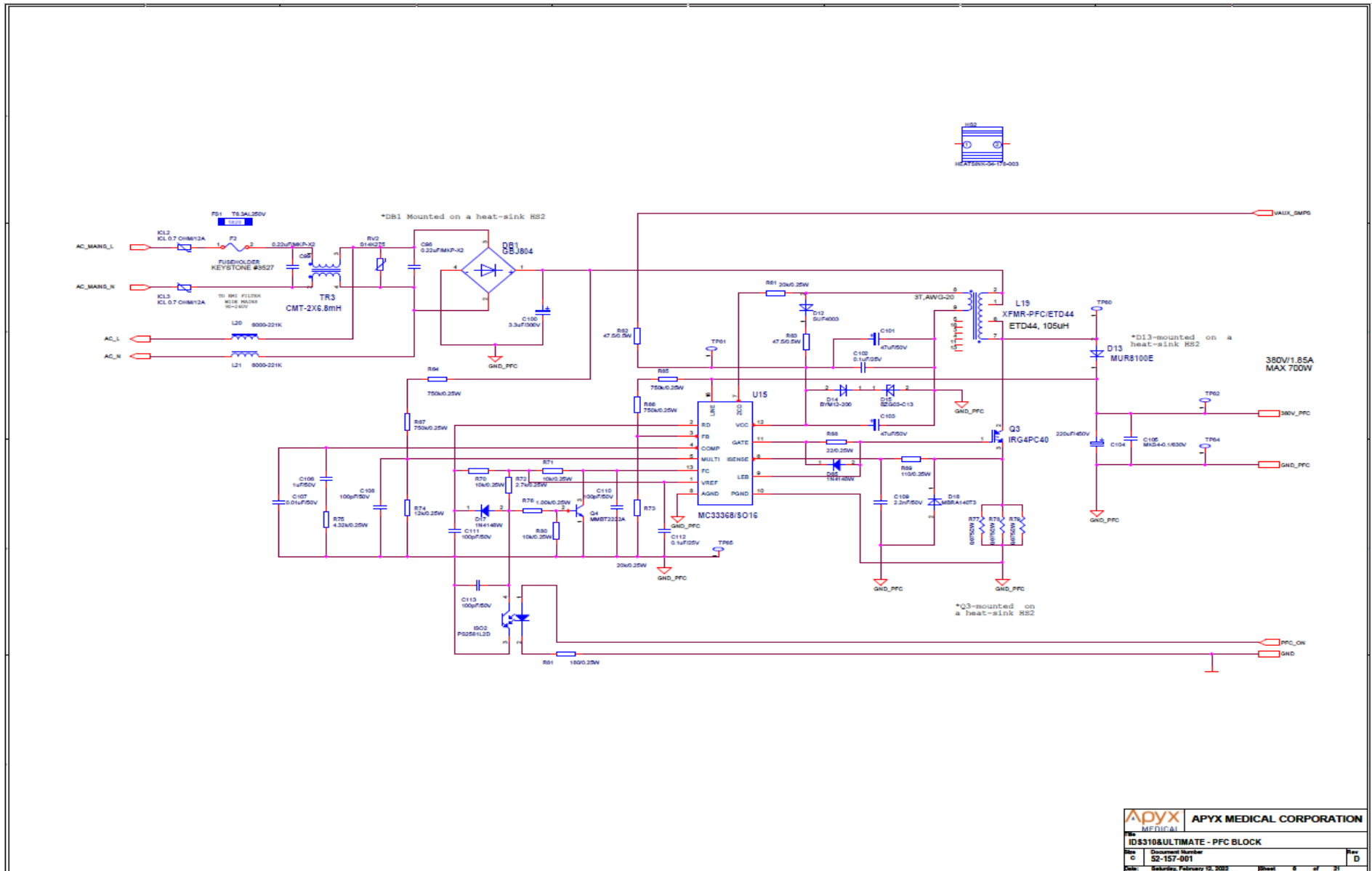

APYX MEDICAL CORPORATION	
IDS310&ULTIMATE - PFC BLOCK	
Rev C	Document Number 52-157-001
Date September, February 10, 2002	Sheet 6 of 21

Schematic 7 Isolated Full Bridge SMPS

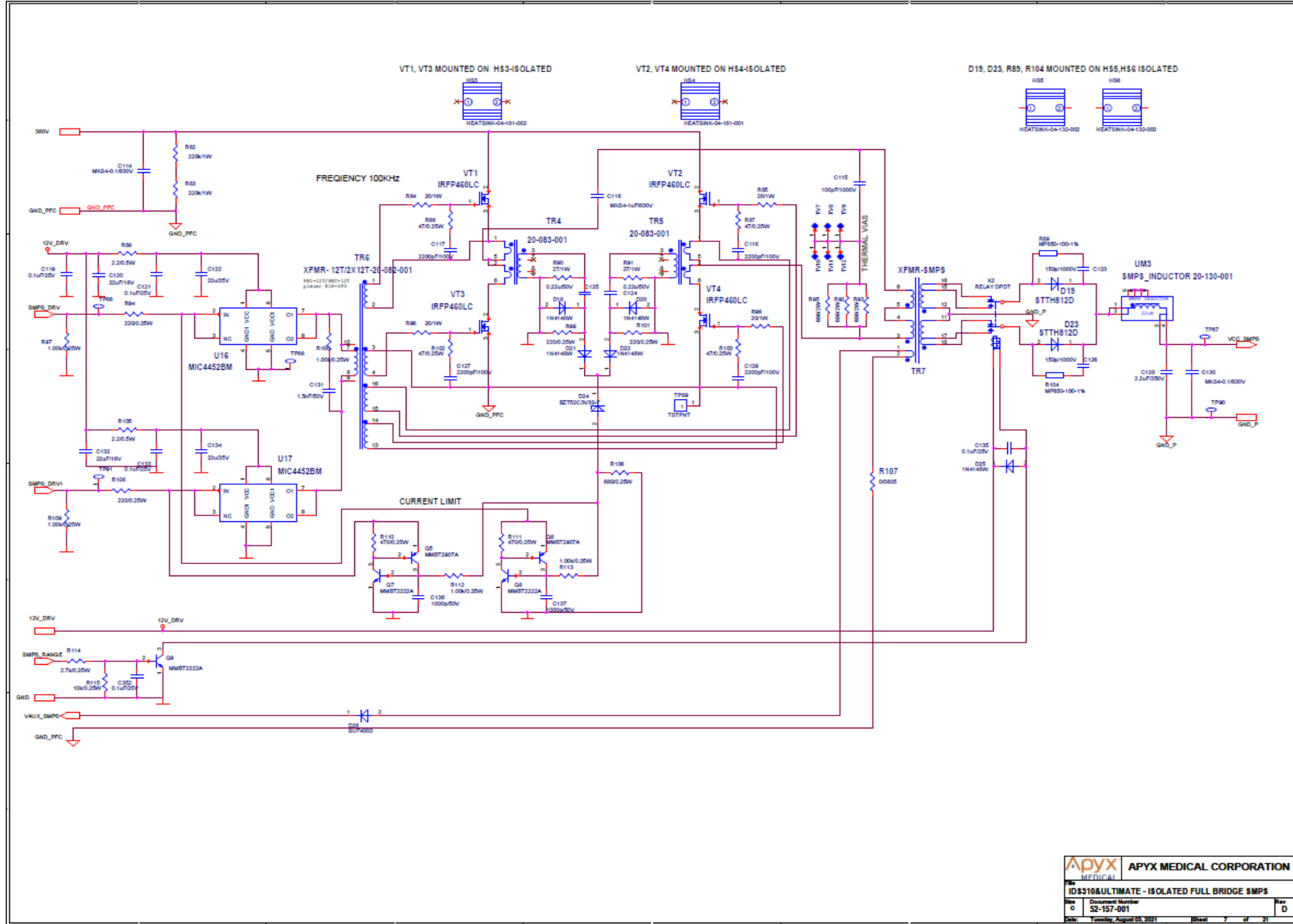

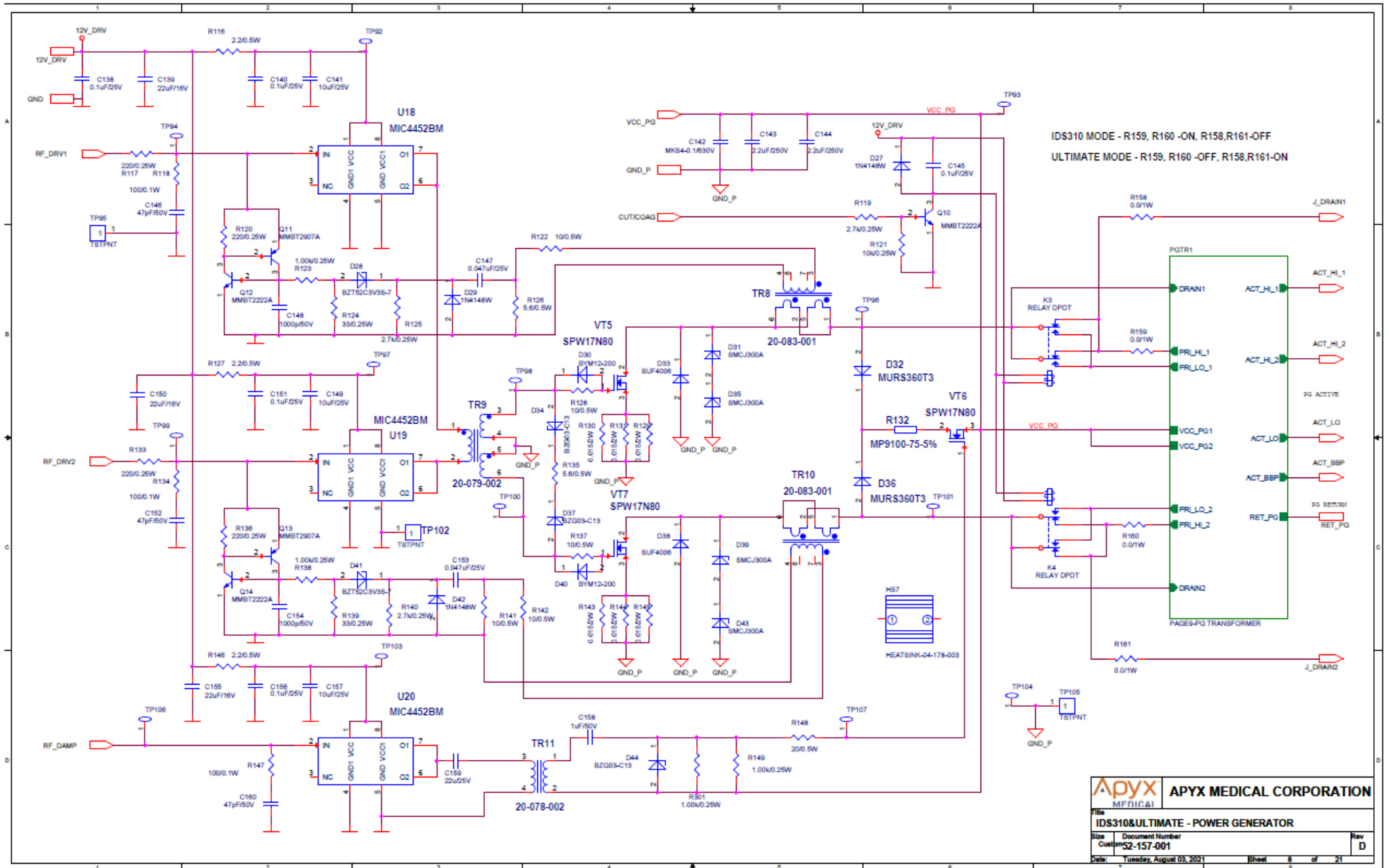

APYX MEDICAL CORPORATION
 No. **ID8310/ULTIMATE - ISOLATED FULL BRIDGE SMPS**
 Rev. **D**
 Date: Tuesday, August 05, 2021

Schematic 8 Power Generator

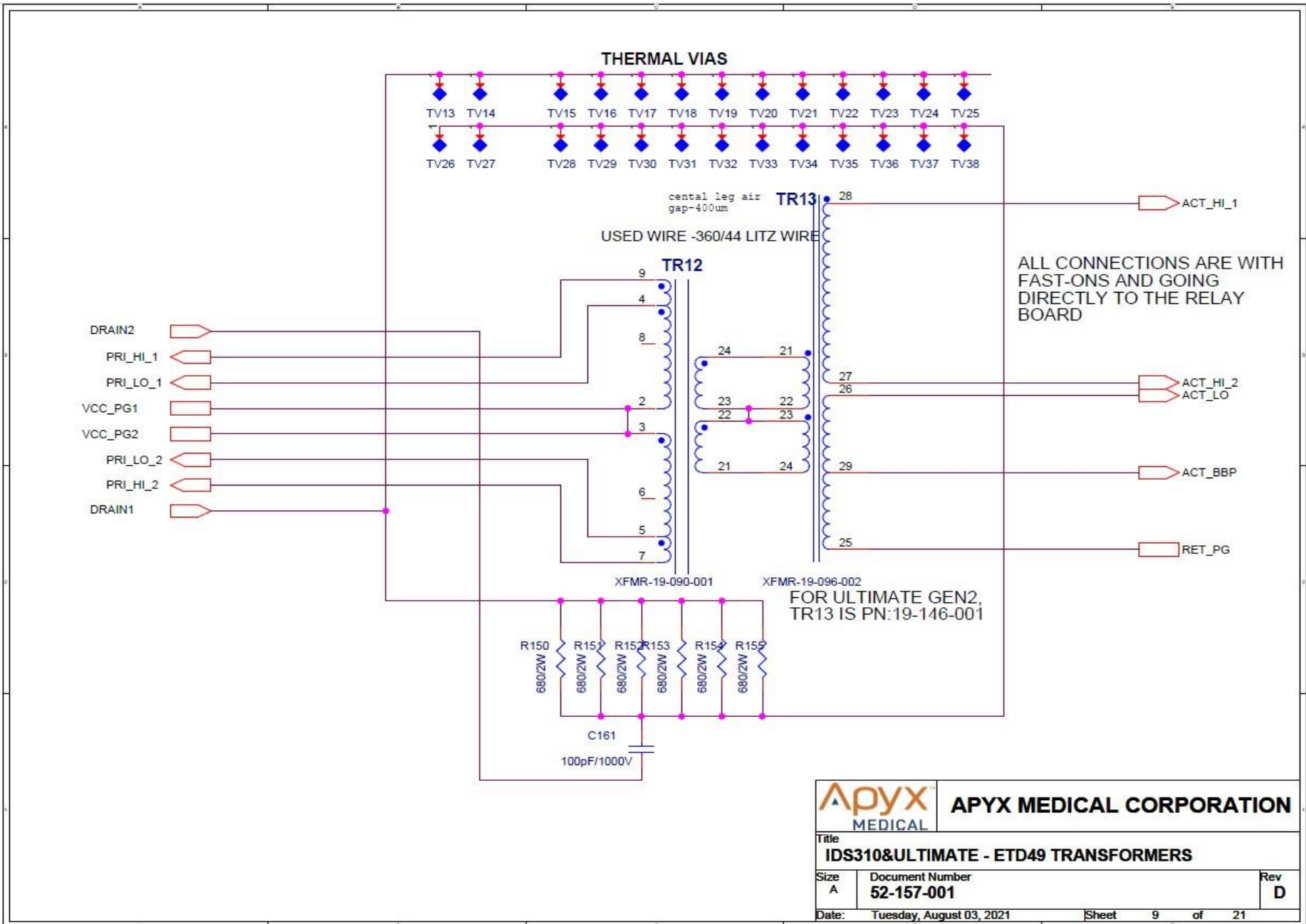

Schematic 9 ETD49 Transformers



Schematic 10 Node Selection and Sensors

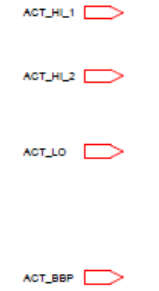
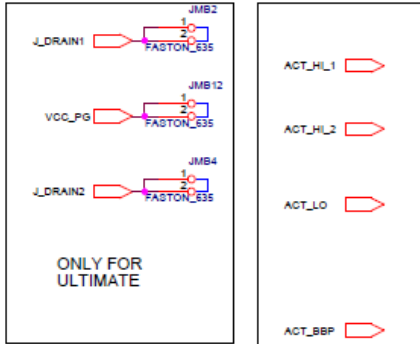

Connections from transformer TR13

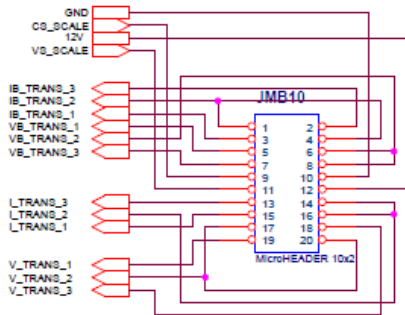
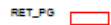

FOR IDS310 - USE THE FOLLOWING PART NUMBERS

BARE PCB P/N 01-155-001
PCB ASSEMBLY P/N 20-160-001
SCHEMATIC P/N 52-158-001

FOR ULTIMATE - USE THE FOLLOWING PART NUMBERS

BARE PCB P/N 01-160-001
PCB ASSEMBLY P/N 20-165-001
SCHEMATIC P/N 52-162-001

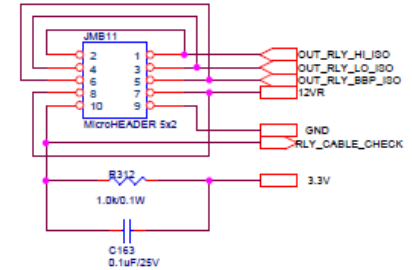

Connection from relay K15, p.3
RET_PG_SE1
RET_PG_SE2
Connection from relay K16, p.4



		APYX MEDICAL CORPORATION	
File IDS310&ULTIMATE - MODE SELECTION AND SENSORS			
Size B	Document Number 52-157-001		Rev D
Date: Tuesday, August 03, 2021		Sheet 18 of 21	

Schematic 11 Sensing A/D

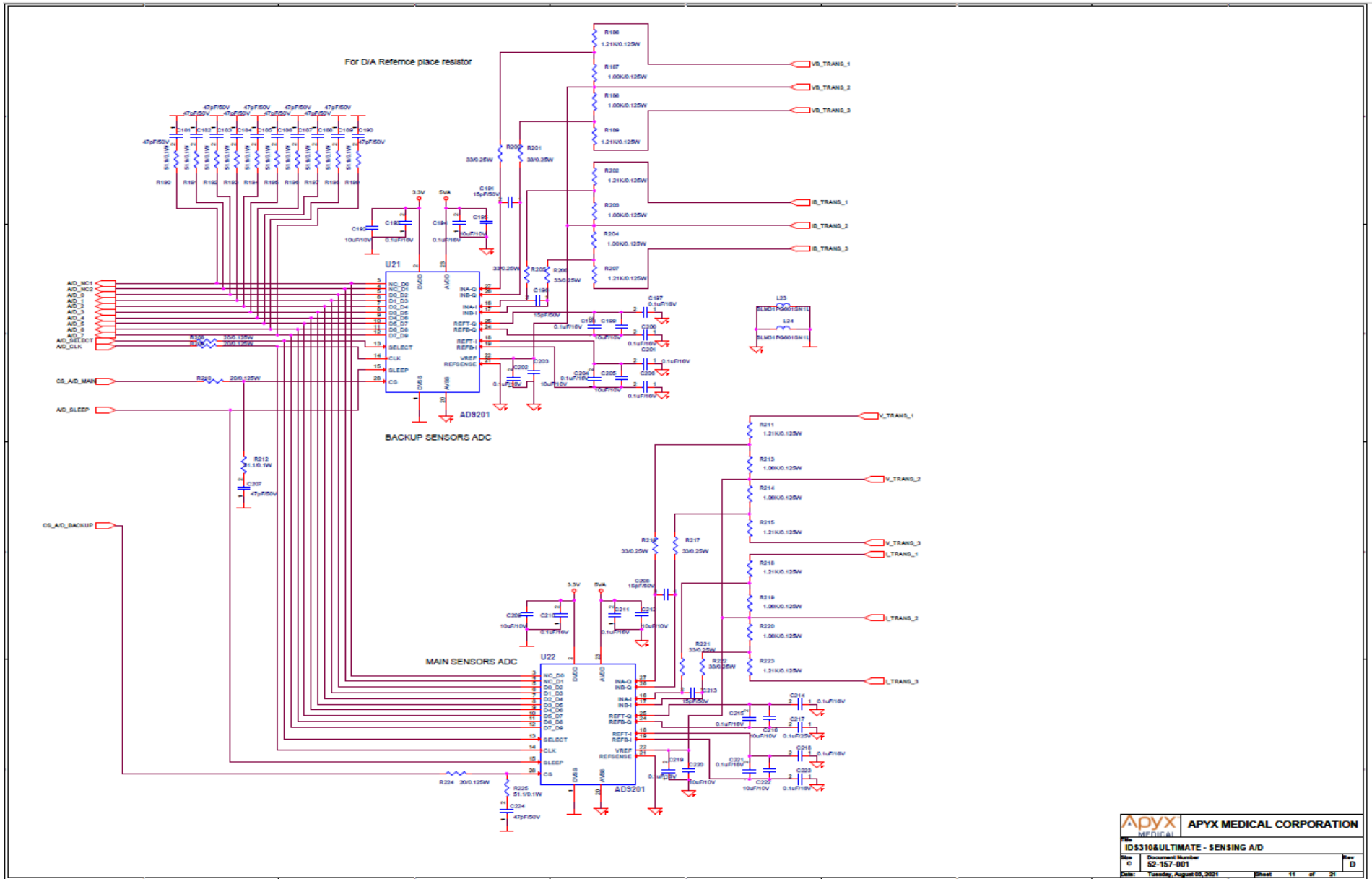

APYX MEDICAL CORPORATION	
IDS310&ULTIMATE - SENSING A/D	
Doc #	Document Number
c	S2-157-001
Date	Thursday, August 05, 2021
Sheet	11 of 31

Schematic 12 Output Relays

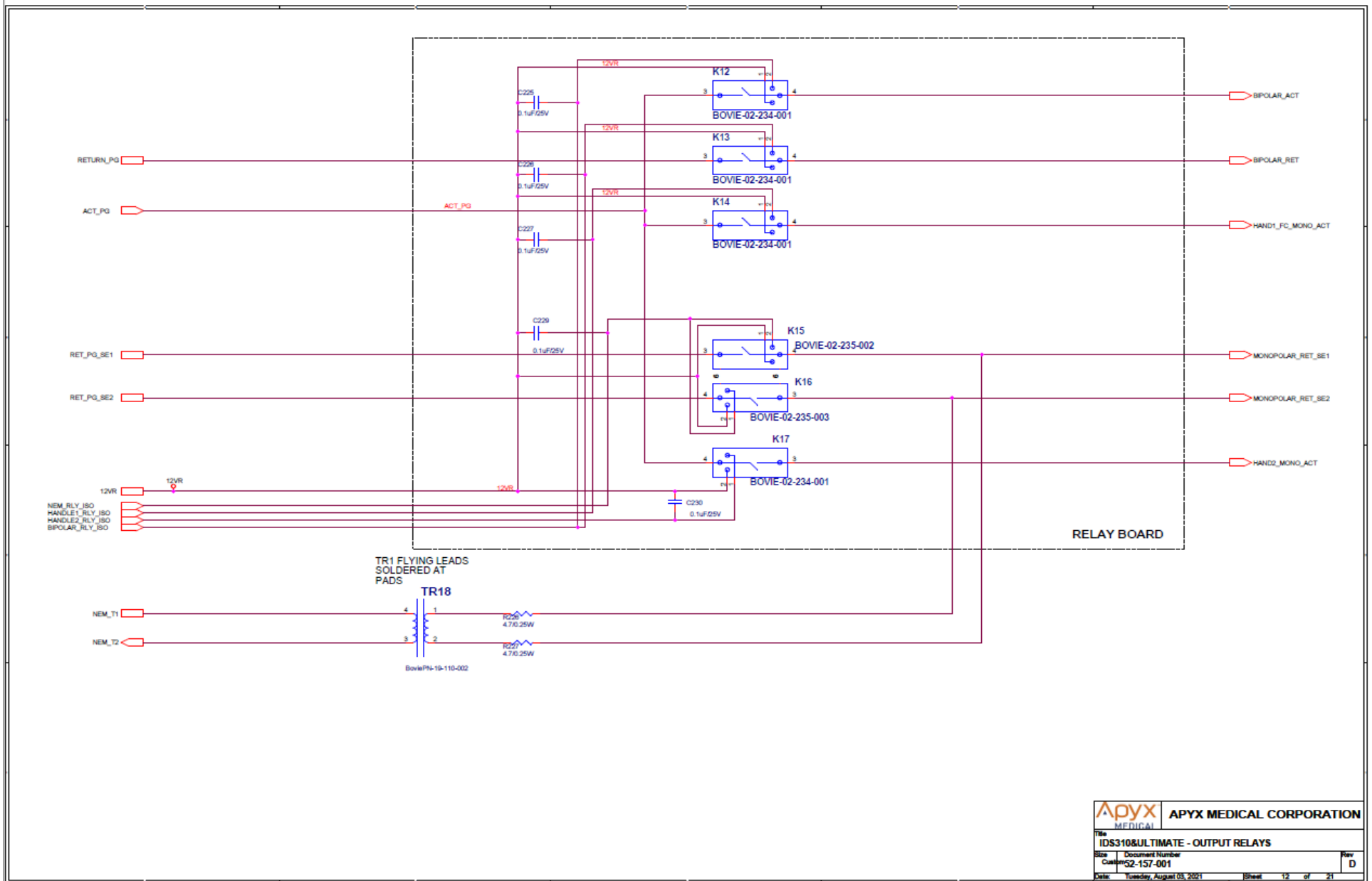

APYX MEDICAL CORPORATION	
File: IDS310&ULTIMATE - OUTPUT RELAYS	
Size: 1	Document Number: S2-157-001
Date: Tuesday, August 03, 2021	Sheet: 12 of 21

Schematic 13 Output Relays Decoder

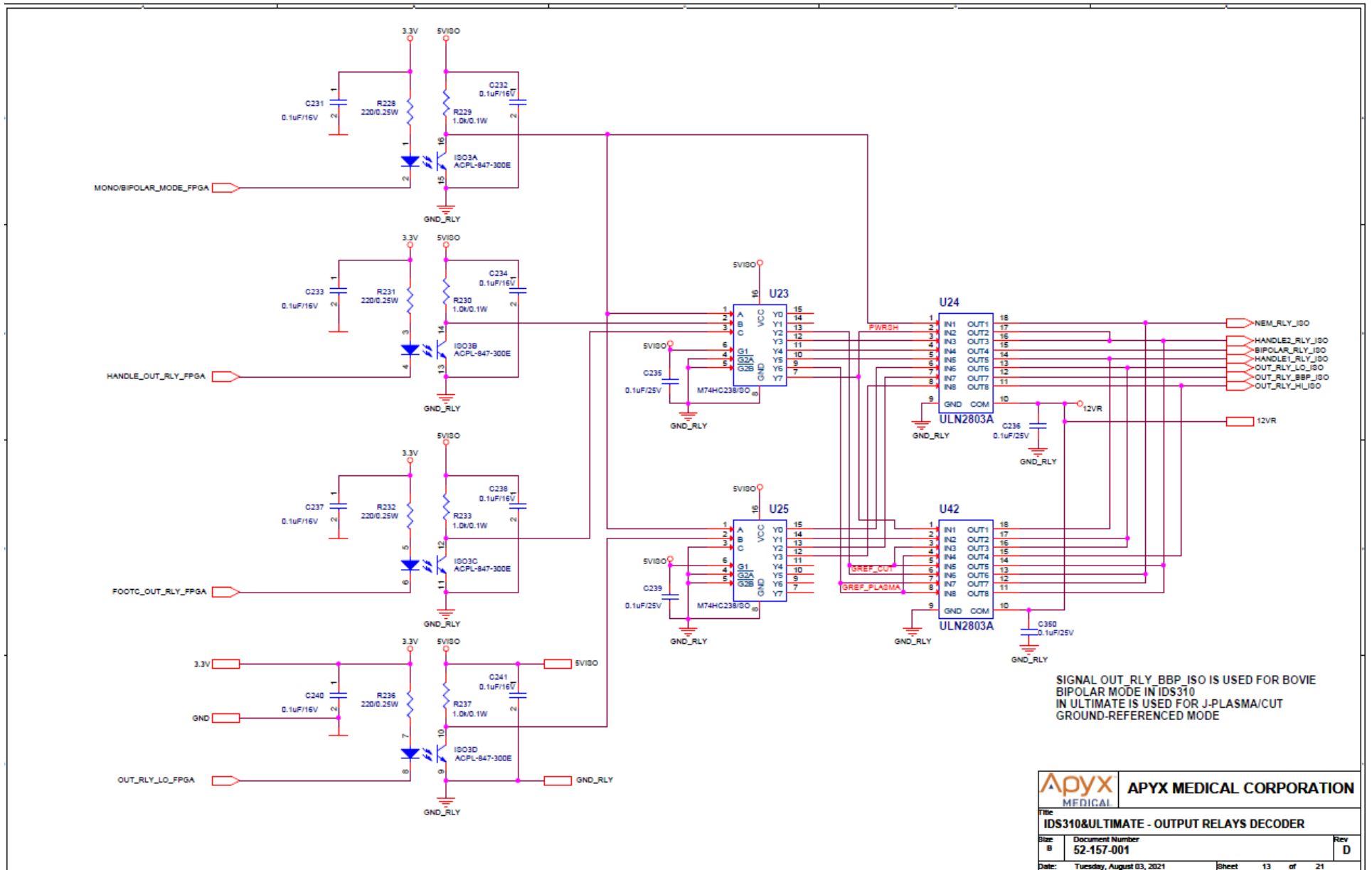

Schematic 14 NEM Circuit

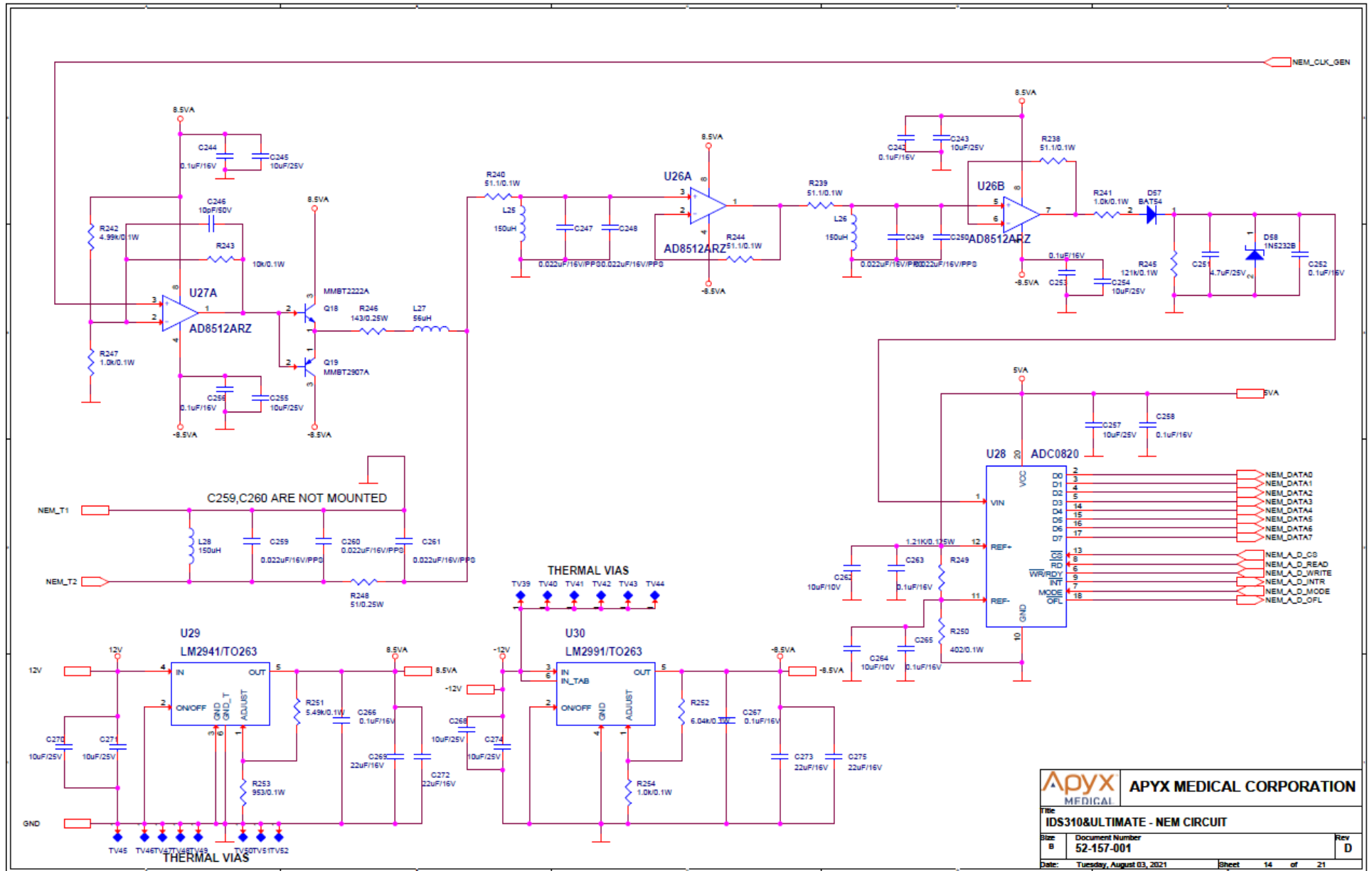

Apyx MEDICAL APYX MEDICAL CORPORATION

Title: **IDS310&ULTIMATE - NEM CIRCUIT**

Size: B Document Number: **52-157-001** Rev: **D**

Date: **Tuesday, August 03, 2021** Sheet: **14** of **21**

Schematic 15 Auto Bipolar Module

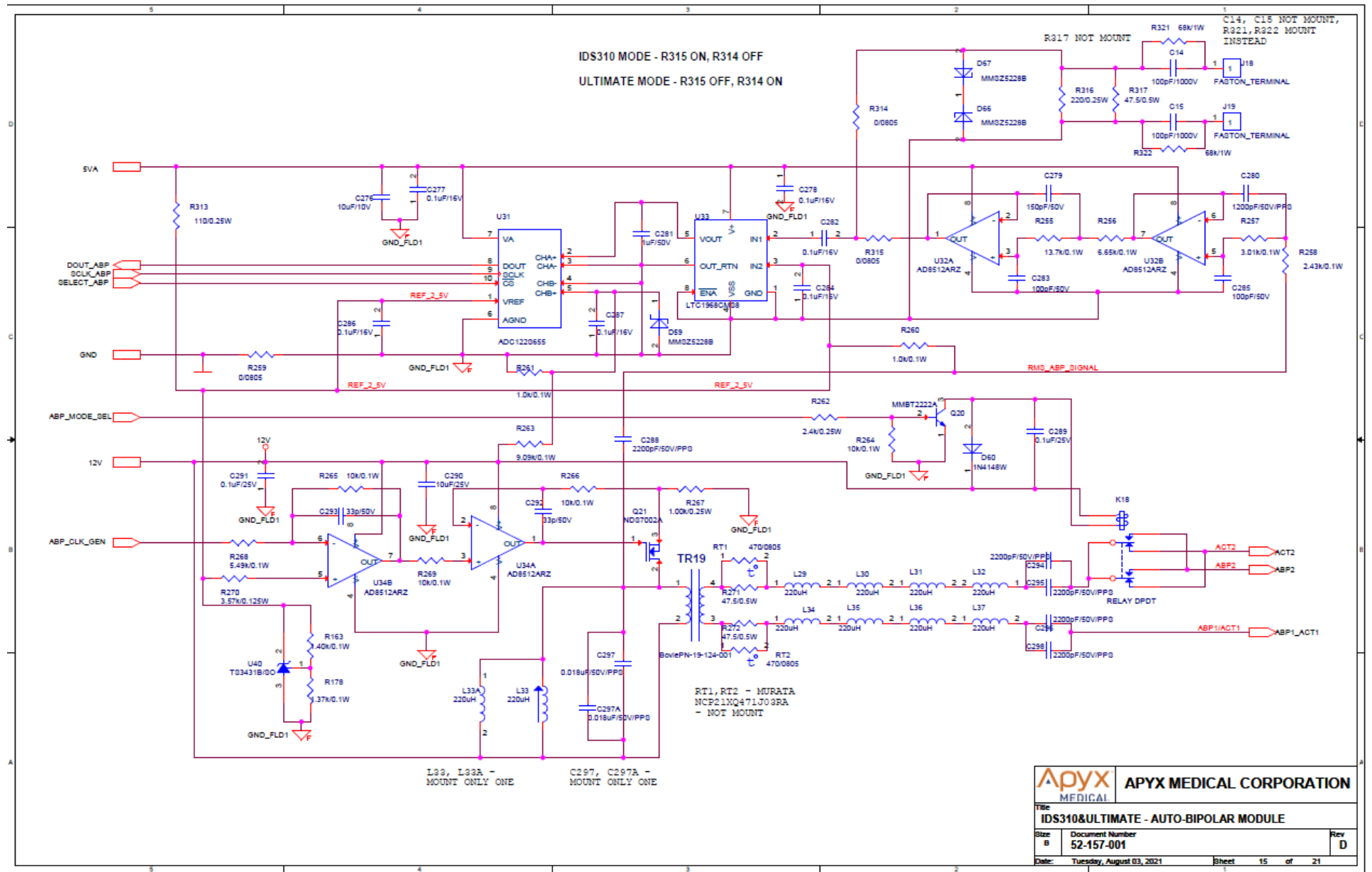

Schematic 16 Audio Control

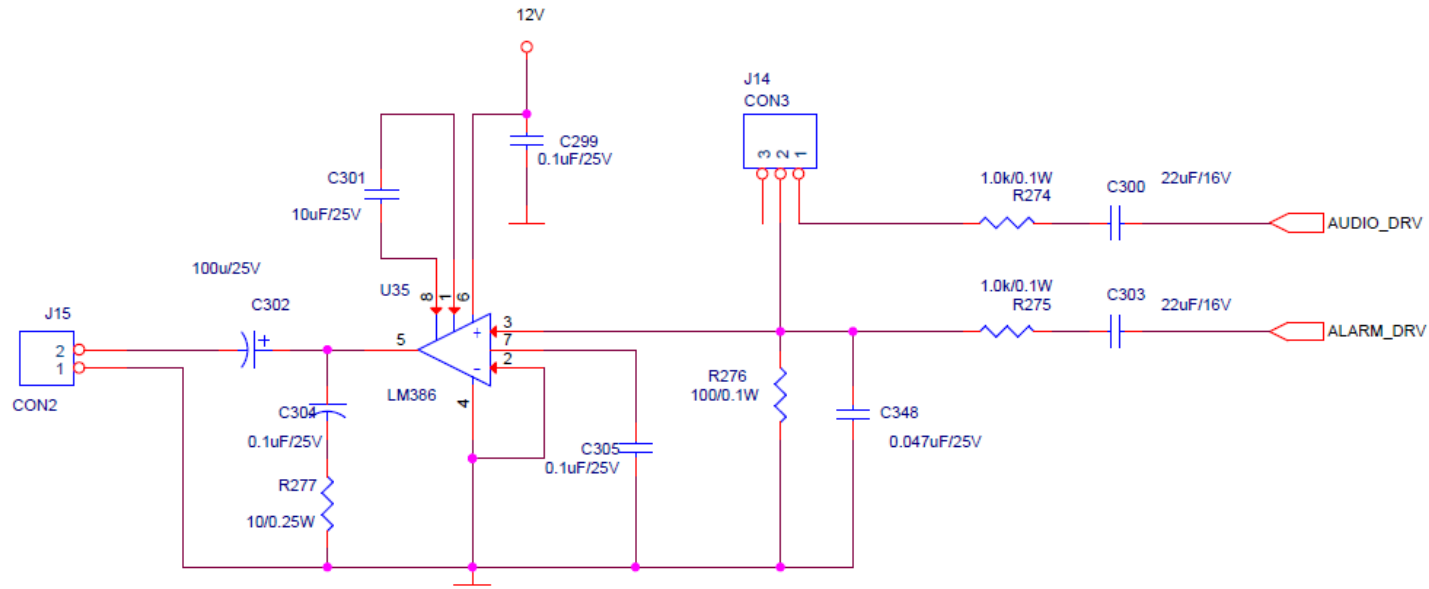

 APYX MEDICAL CORPORATION	
Title IDS310&ULTIMATE - AUIDO CONTROL	
Size A	Document Number 52-157-001
Date: Tuesday, August 03, 2021	
Rev D	
Sheet 16 of 21	

Schematic 17 1-Wire Interface

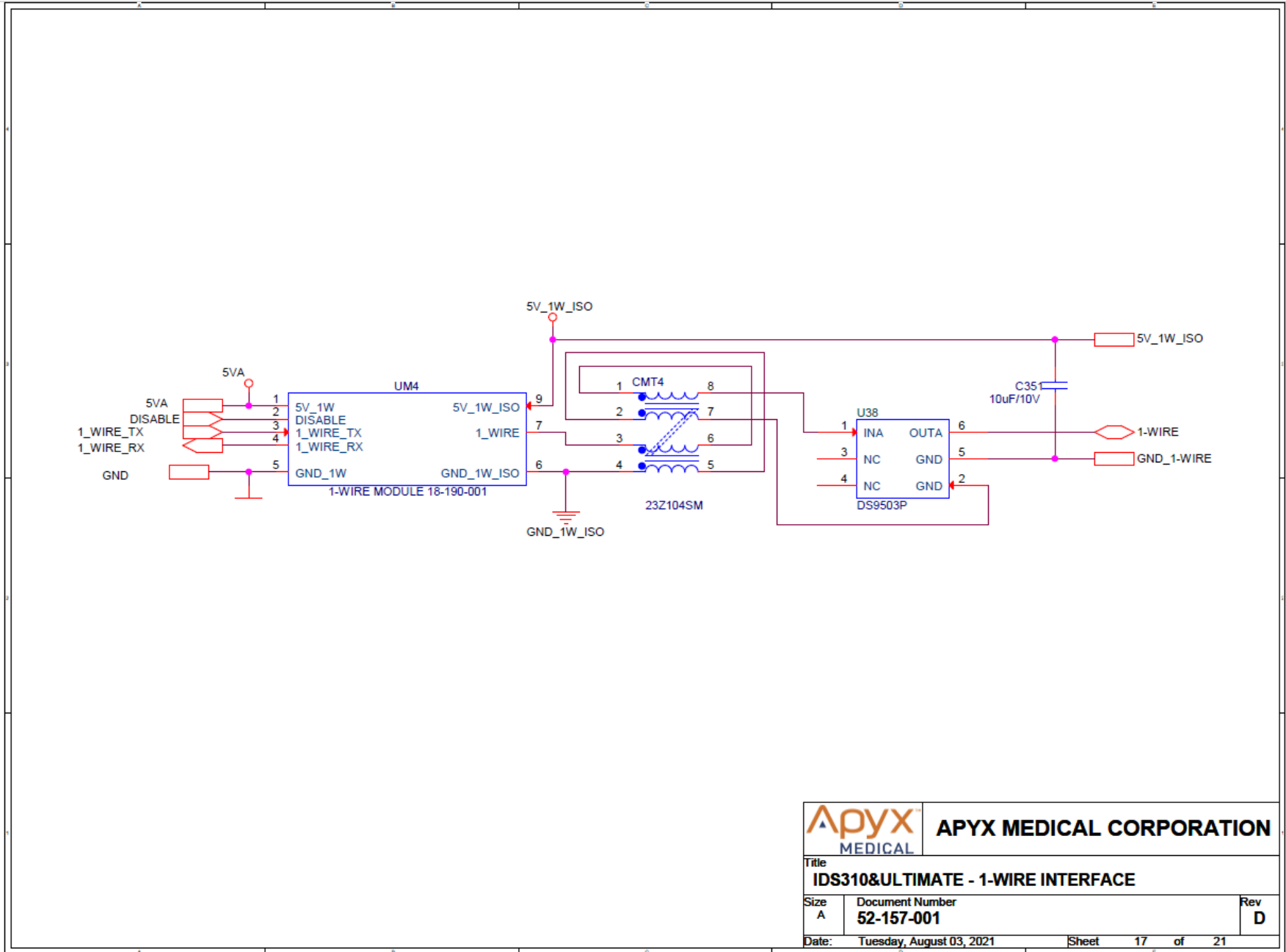

Schematic 18 Test A/D

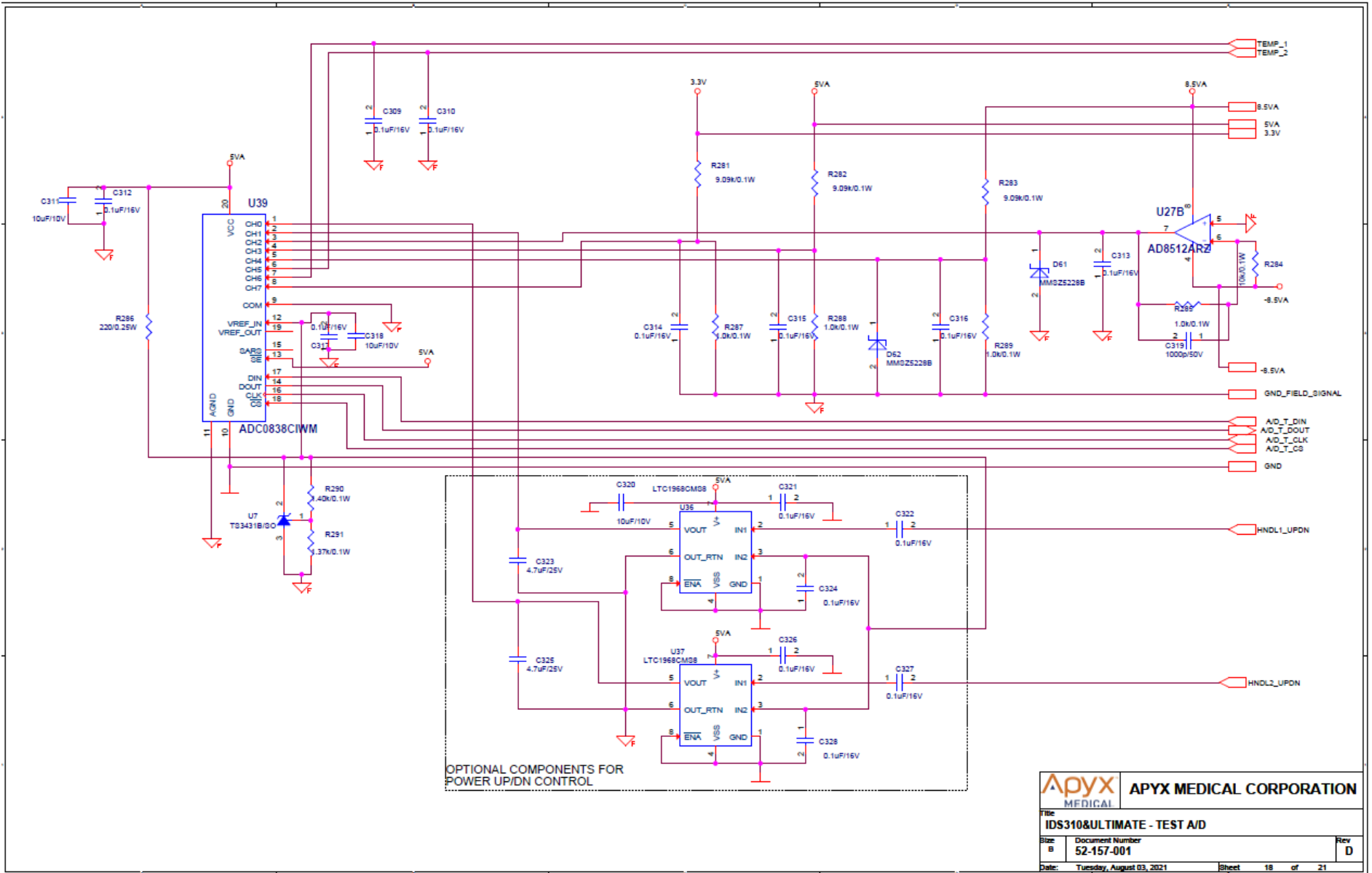

APYX MEDICAL CORPORATION

APYX MEDICAL

File: **IDS310&ULTIMATE - TEST A/D**

Size: B	Document Number: 52-157-001	Rev: D
Date: Tuesday, August 03, 2021	Sheet: 18 of 21	

Schematic 19 Mounting Bosses and Holes

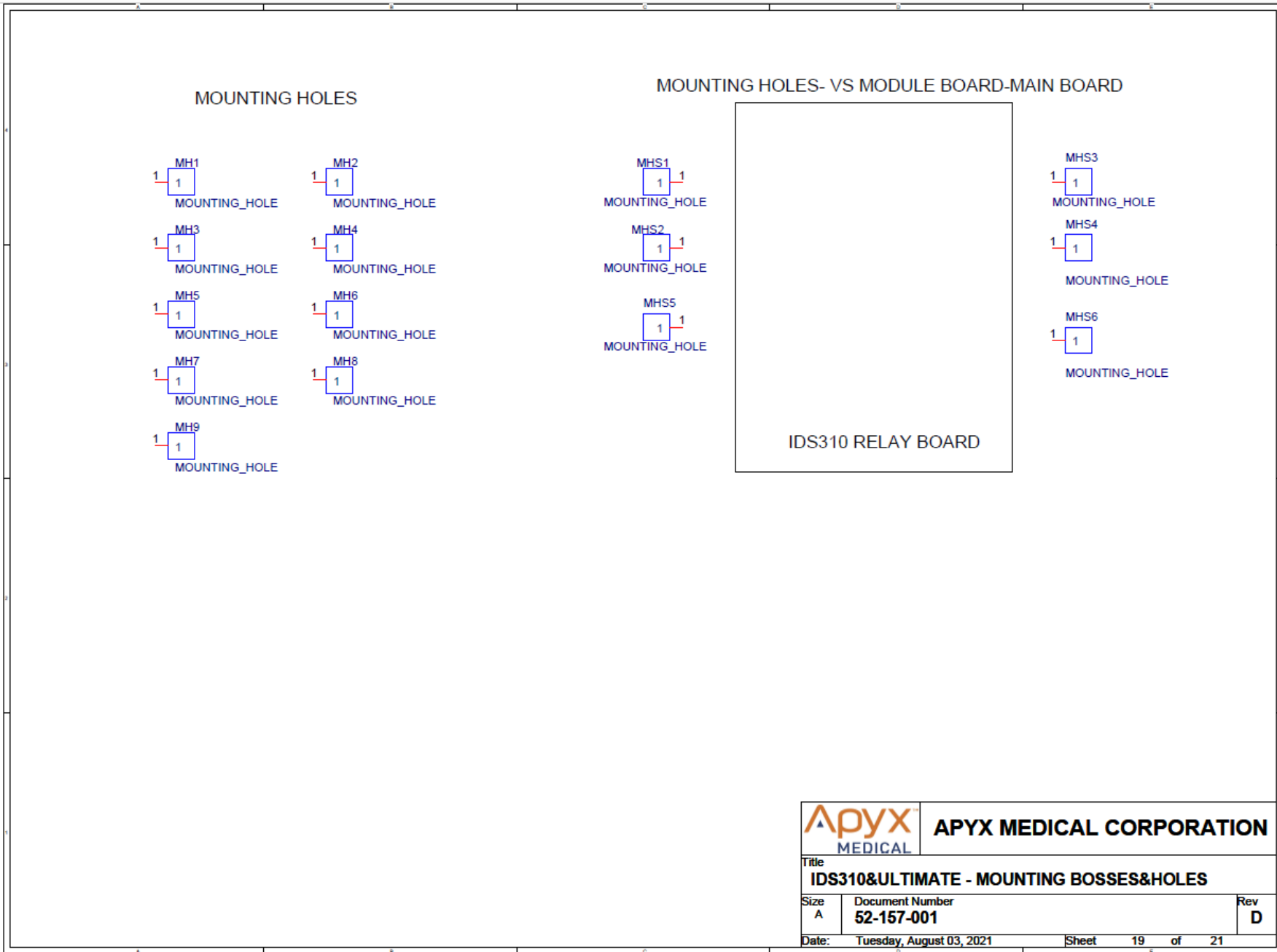

 APYX MEDICAL CORPORATION	
Title IDS310&ULTIMATE - MOUNTING BOSSES&HOLES	
Size A	Document Number 52-157-001
Date: Tuesday, August 03, 2021	Rev D
Sheet 19 of 21	

Schematic 20 Mono FSW & FOOTC Recognition

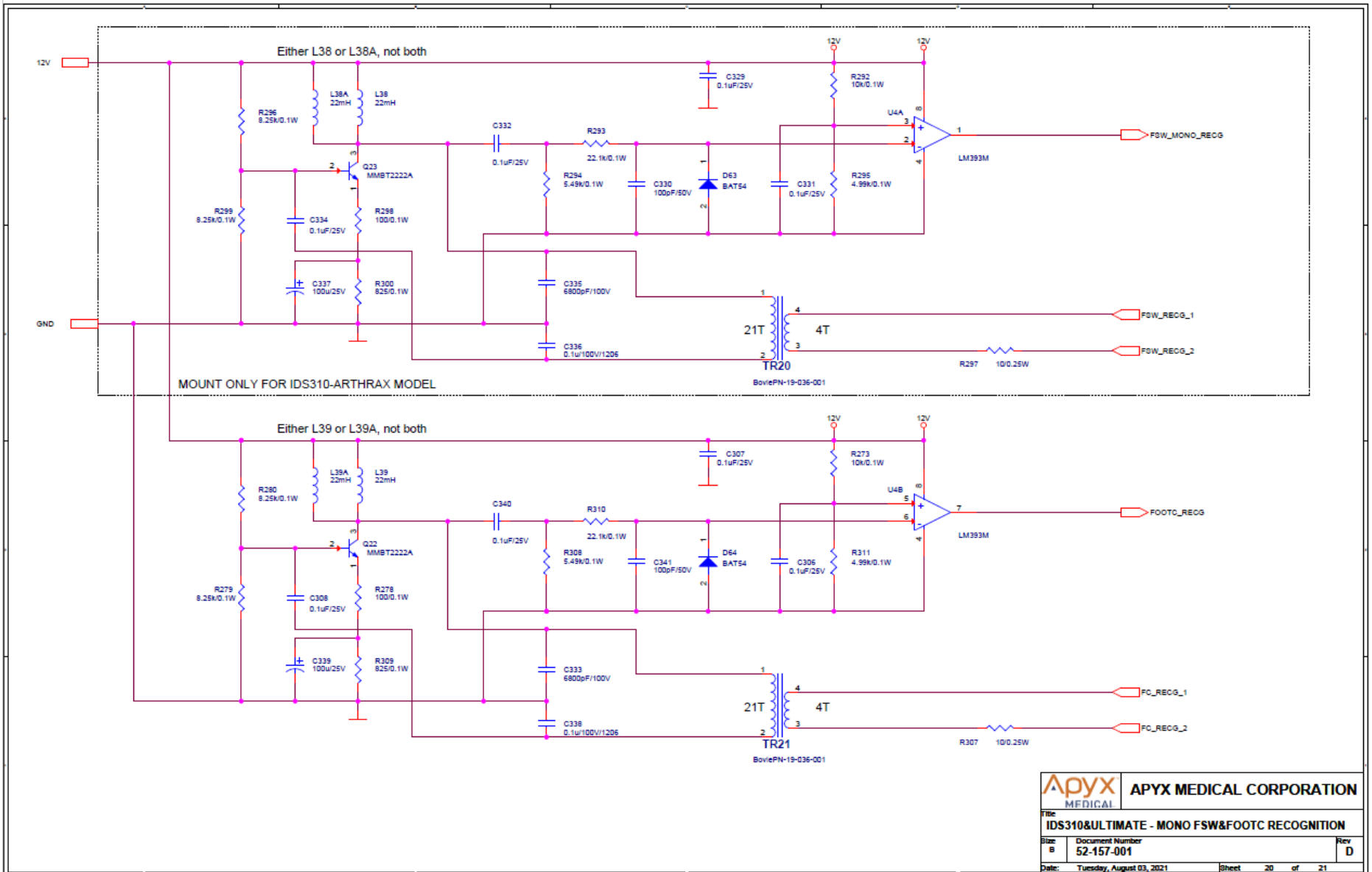

Schematic 21 Logic PS, Buck Regulator

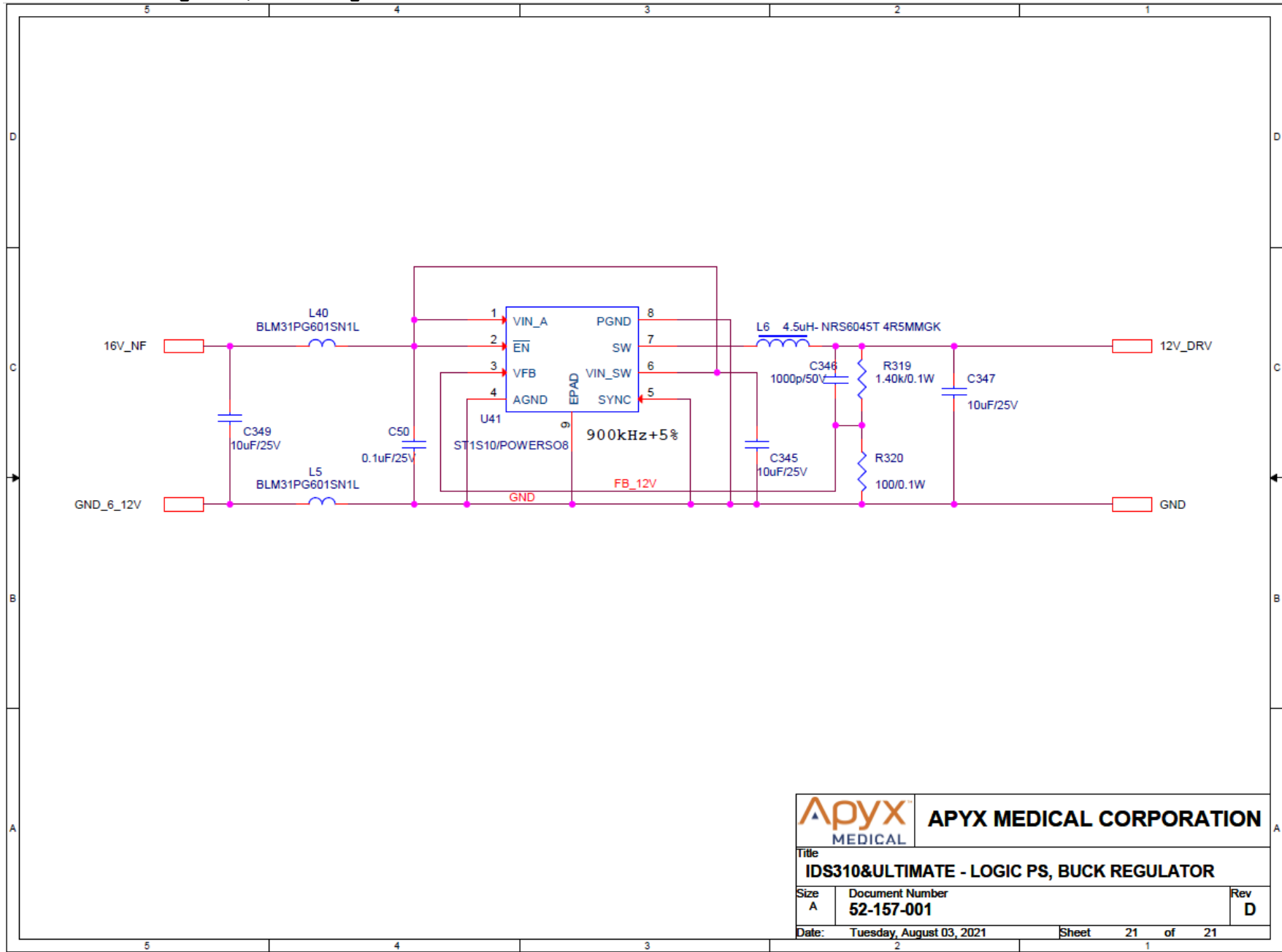

Schematic 22 Relay Board Top

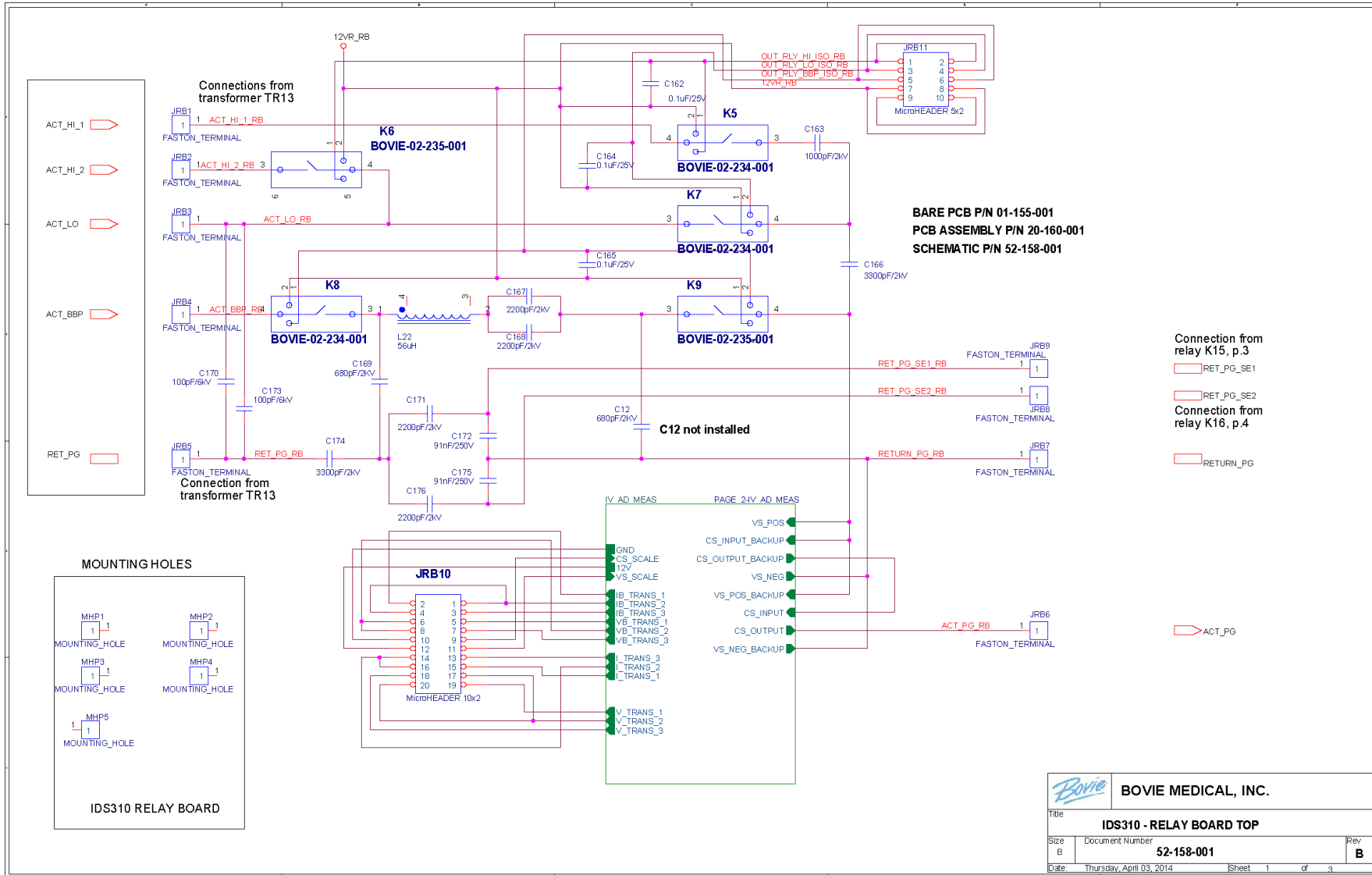

Schematic 23 Relay Board V-I-Sensors

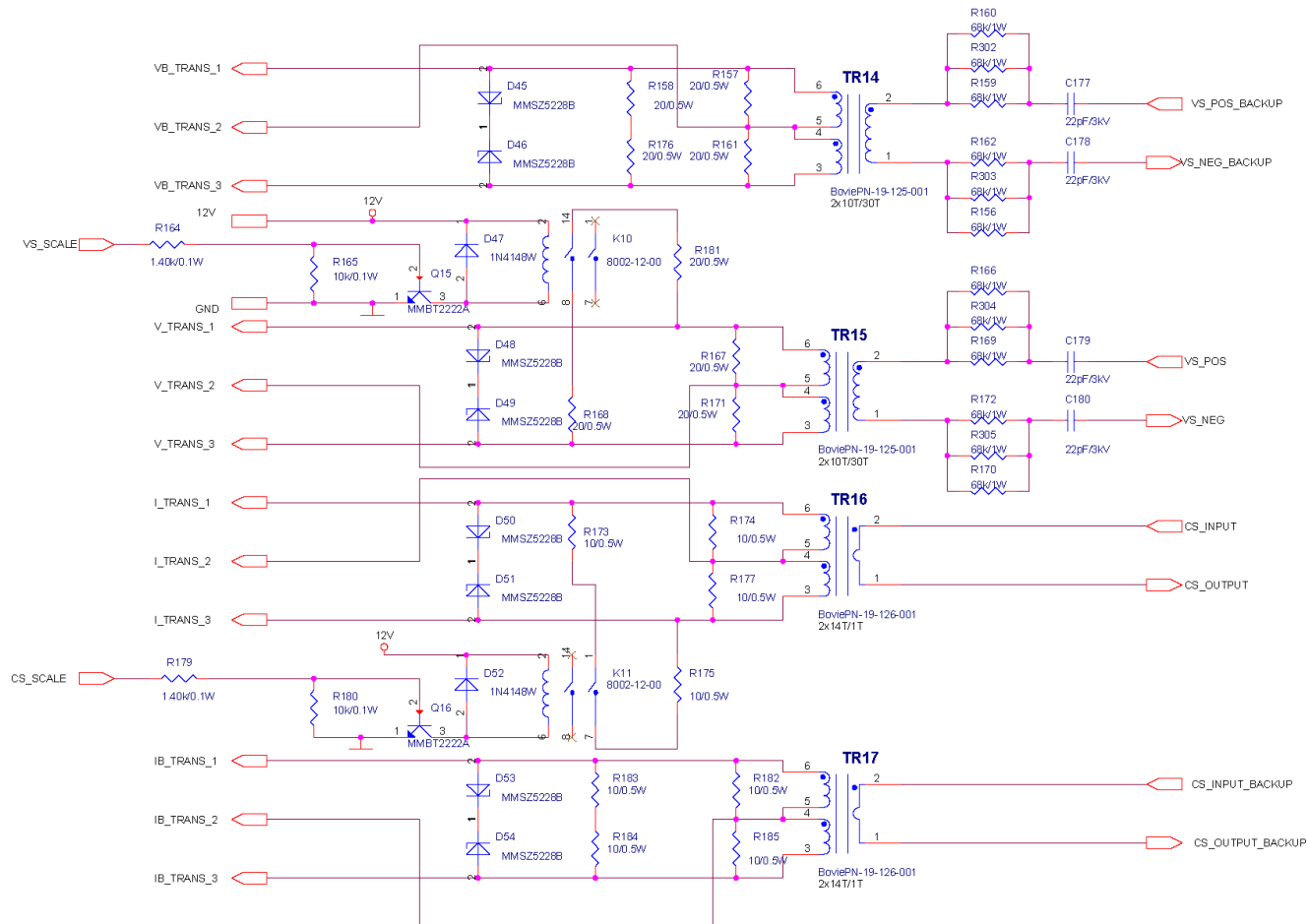

		BOVIE MEDICAL INDUSTRIES, INC.	
Title			
IDS310 RELAY BOARD V-I-SENSORS			
Size	Document Number		Rev
	52-158-001		B
Date	Thursday, April 03, 2014	Sheet	2 of 3

Schematic 24 Display Board Page 1

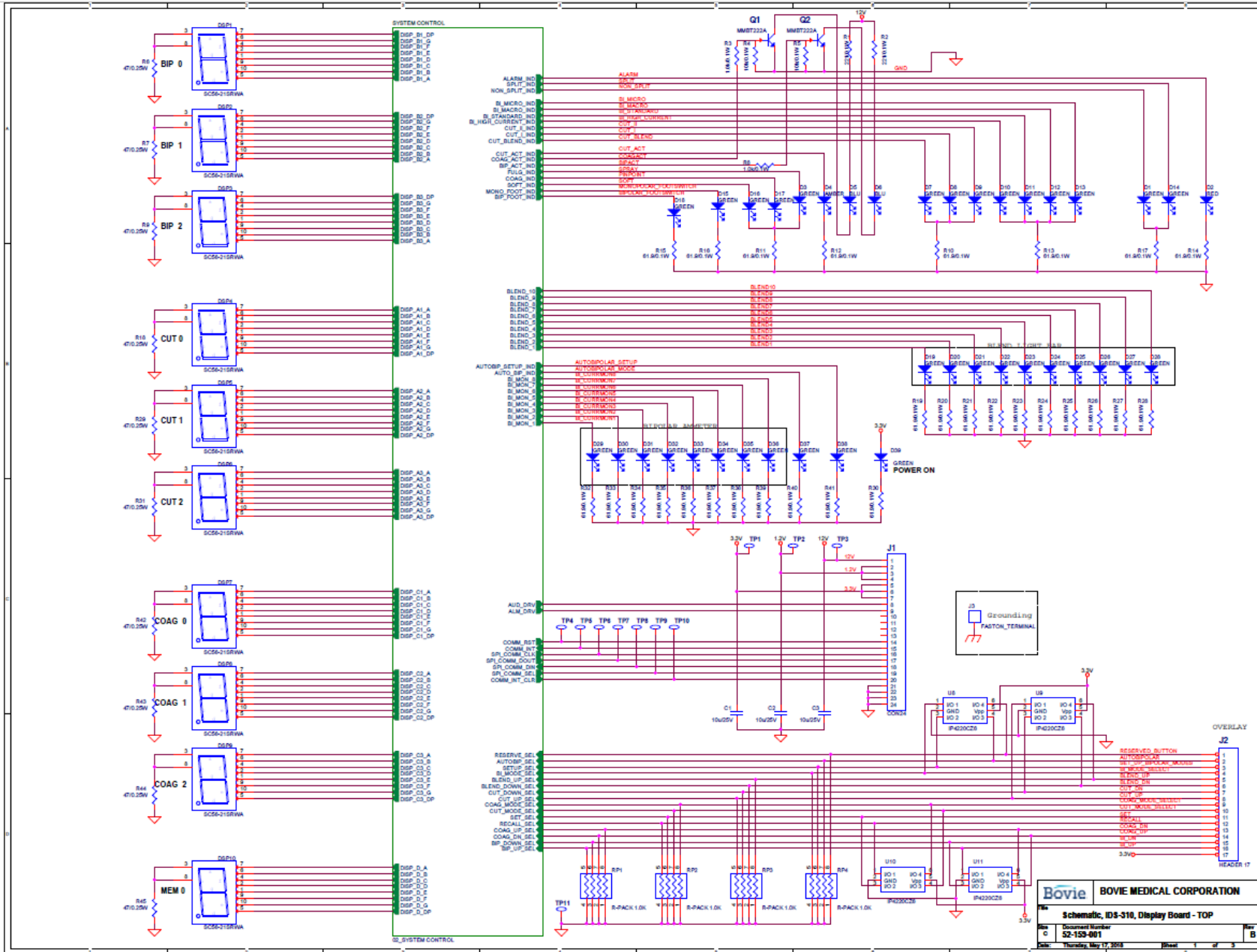

Schematic 25 Display Board Page 2

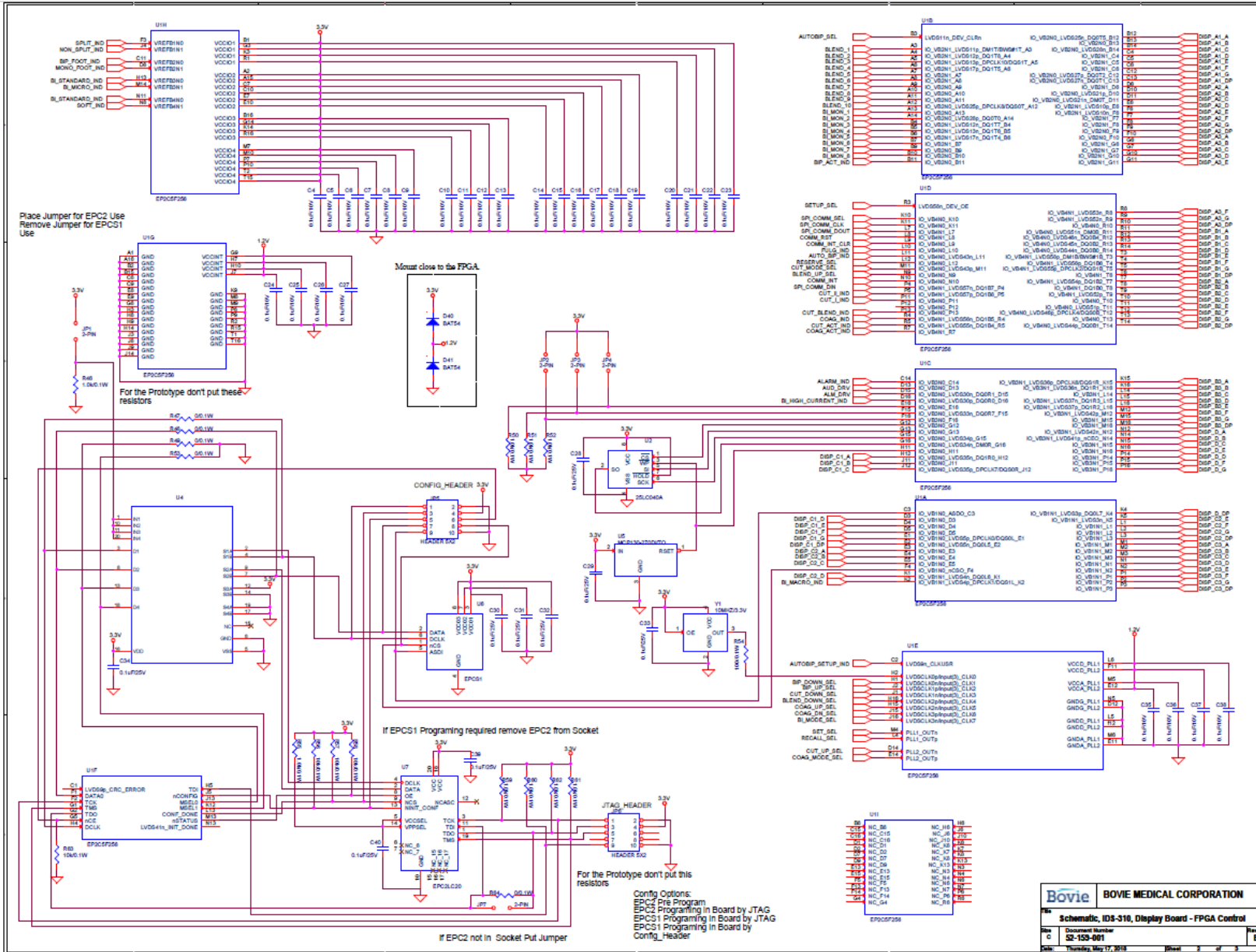

Bovie		BOVIE MEDICAL CORPORATION	
Schematic, IDS-310, Display Board - FPGA Control			
Rev	C	Document Number	DS-103-001
Date	Monday, May 17, 2010	Sheet	2 of 3

Schematic 26 Connector Panel

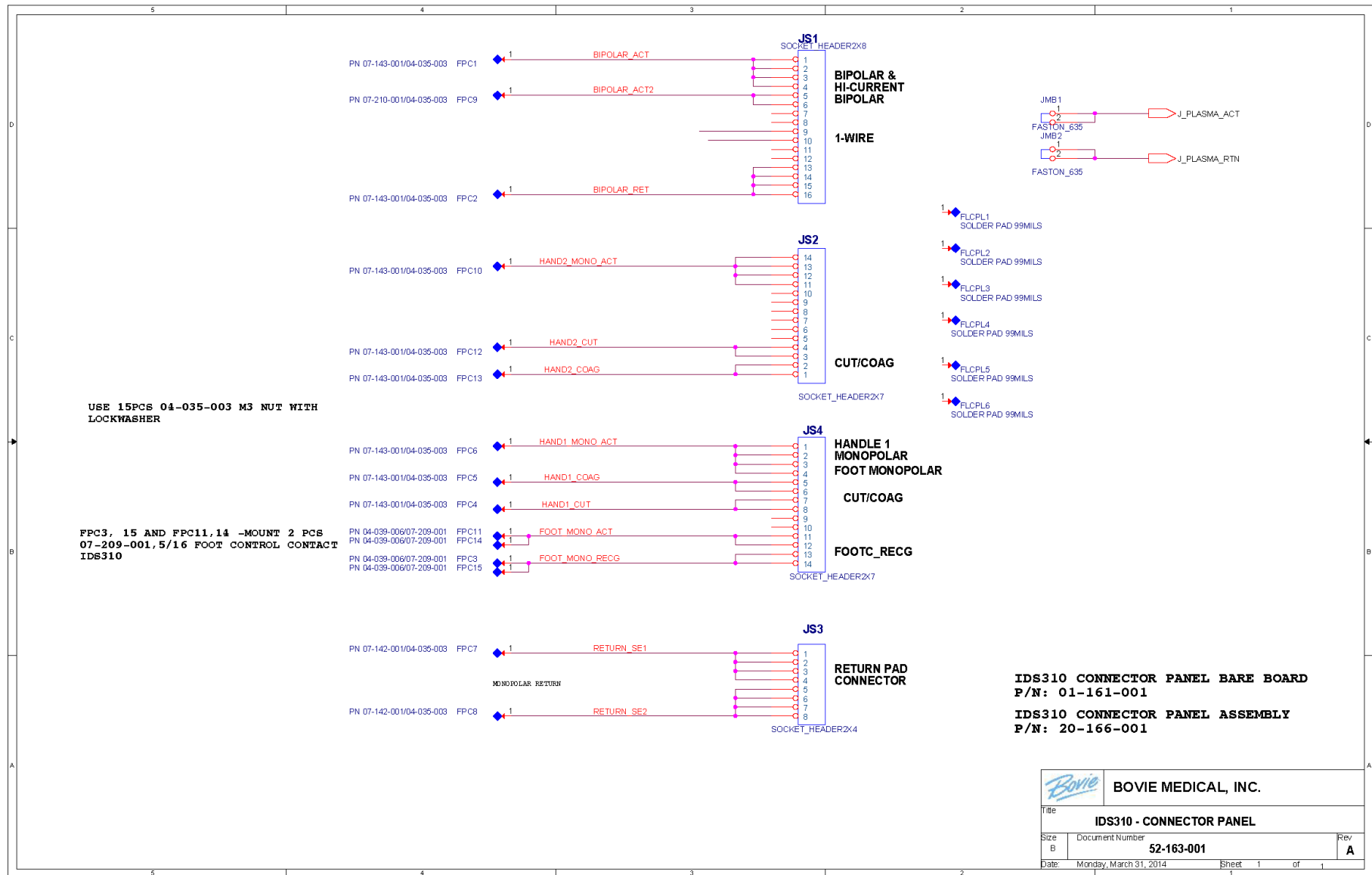

Printed Circuit Board 1 Relay Board Top

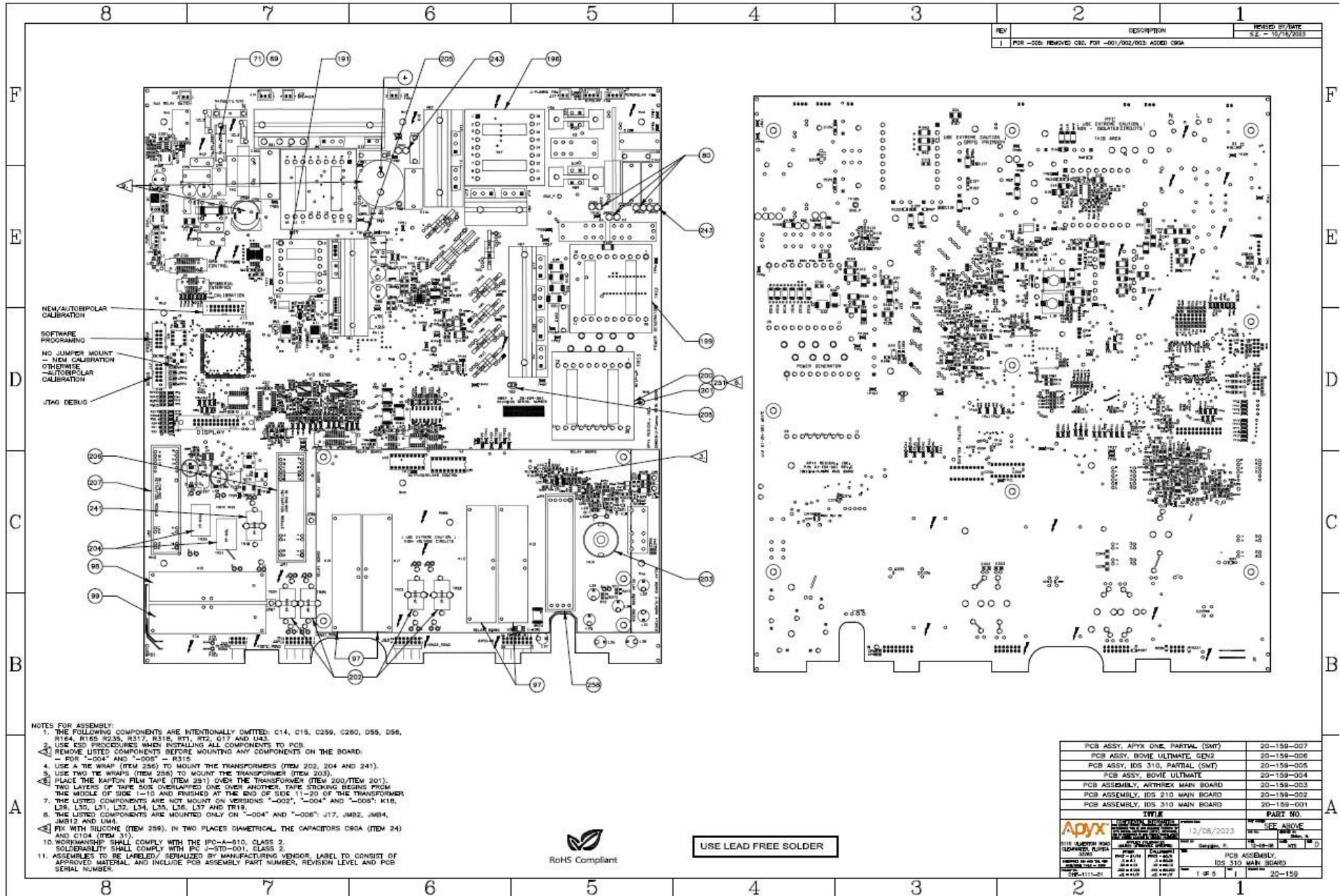

Printed Circuit Board 2 Main Board

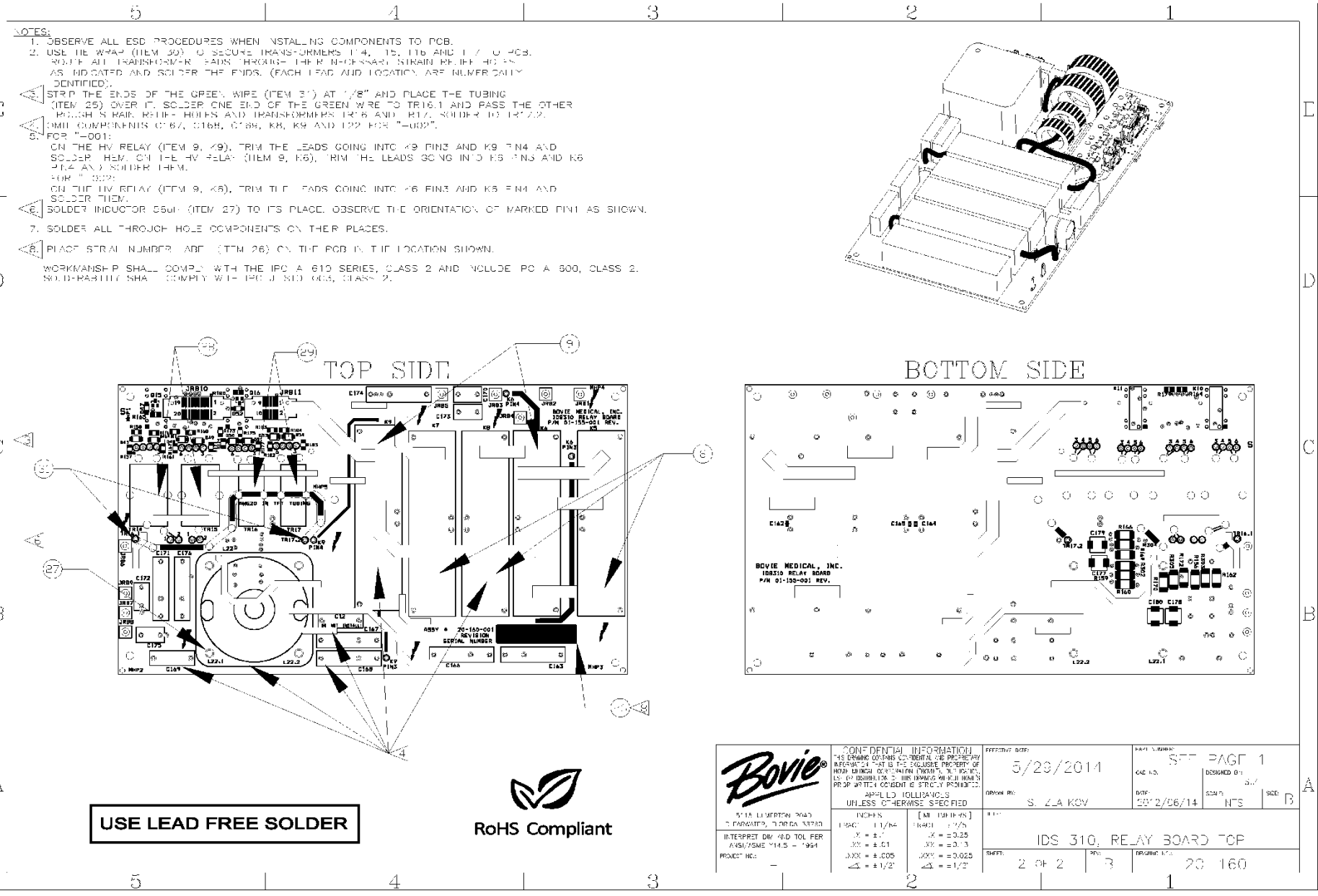

- NOTES:**
- OBSERVE ALL ESD PROCEDURES WHEN INSTALLING COMPONENTS TO PCB.
 - USE THE WHIPS (ITEM 30) TO SECURE TRANSFORMERS TR4, TR5, TR6 AND TR7 TO PCB. REMOVE ALL TRANSFORMER LEADS THROUGH THE HOLE(S) AND STRIP THE LEADS AS INDICATED AND SOLDER THE ENDS. (EACH LEAD AND LOCATION ARE NUMERICALLY IDENTIFIED).
 - STRIP THE ENDS OF THE GREEN WIRE (ITEM 31) AT 1/8" AND PLACE THE TUBING (ITEM 25) OVER IT. SOLDER ONE END OF THE GREEN WIRE TO TR16.1 AND PASS THE OTHER THROUGH THE HOLE, REMOVE HOLES AND TRANSFORMERS TR6 AND TR7. SOLDER TO TR7.2.
 - OMIT COMPONENTS C67, C168, C169, K8, K9 AND L22 FOR "-001".
 - FOR "-001":
ON THE HV RELAY (ITEM 9, K9), TRIM THE LEADS GOING INTO K9 PIN3 AND K9 PIN4 AND SOLDER THEM. ON THE HV RELAY (ITEM 9, K6), TRIM THE LEADS GOING INTO K6 PIN3 AND K6 PIN4 AND SOLDER THEM.
 - ON THE HV RELAY (ITEM 9, K6), TRIM THE LEADS GOING INTO K6 PIN3 AND K6 PIN4 AND SOLDER THEM.
 - SOLDER INDUCTOR C66H TO ITS PLACE. OBSERVE THE ORIENTATION OF MARKED PIN1 AS SHOWN.
 - SOLDER ALL THROUGH HOLE COMPONENTS ON THEIR PLACES.
 - PLACE STRIP NUMBER 26 (ITEM 26) ON THE PCB IN THE LOCATION SHOWN.
- WORKMANSHIP SHALL COMPLY WITH THE IPC-A-610 SERIES, CLASS 2 AND INCLUDE IPC-A-600, CLASS 2. SOLDERABILITY SHALL COMPLY WITH IPC-J-810, CLASS 2.

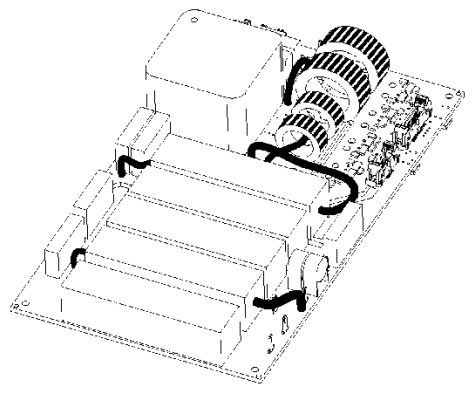

USE LEAD FREE SOLDER



<p>Bovie 5716 LEMMON ROAD FARGO, ND 58103 INTERPRET DRAWING TOL PER PUBLISHED 11.0 - 1994 PROJECT NO.:</p>	<p>CONFIDENTIAL INFORMATION THIS DRAWING CONTAINS CONFIDENTIAL AND PROPRIETARY INFORMATION THAT IS THE EXCLUSIVE PROPERTY OF BOVIE MEDICAL CORPORATION. IT IS NOT TO BE REPRODUCED OR TRANSMITTED IN ANY FORM OR BY ANY MEANS, ELECTRONIC OR MECHANICAL, INCLUDING PHOTOCOPYING, RECORDING, OR BY ANY INFORMATION STORAGE AND RETRIEVAL SYSTEM, WITHOUT THE WRITTEN PERMISSION OF BOVIE MEDICAL CORPORATION.</p> <p>APPROVED FOR RELEASE UNLESS OTHERWISE SPECIFIED</p> <p>INCHES FRACTIONS DECIMALS TOLERANCES UNLESS OTHERWISE SPECIFIED</p> <p>[MILLIMETERS] FRACTIONS DECIMALS TOLERANCES UNLESS OTHERWISE SPECIFIED</p>	<p>DATE: 5/29/2014</p> <p>DESIGNED BY: S. Z. A. KOV</p> <p>DATE: 02/26/14</p> <p>SCALE: 2 of 2</p>	<p>PAGE NUMBER: SFT PAGE 1</p> <p>CAD NO.:</p> <p>DESIGNED BY: S. Z. A. KOV</p> <p>DATE: 02/26/14</p> <p>SCALE: NTS</p> <p>SHEET: 3</p> <p>FIGURE NO.: 20 160</p>
		<p>IDS 310, RELAY BOARD TOP</p>	

Printed Circuit Board 3 Display Board

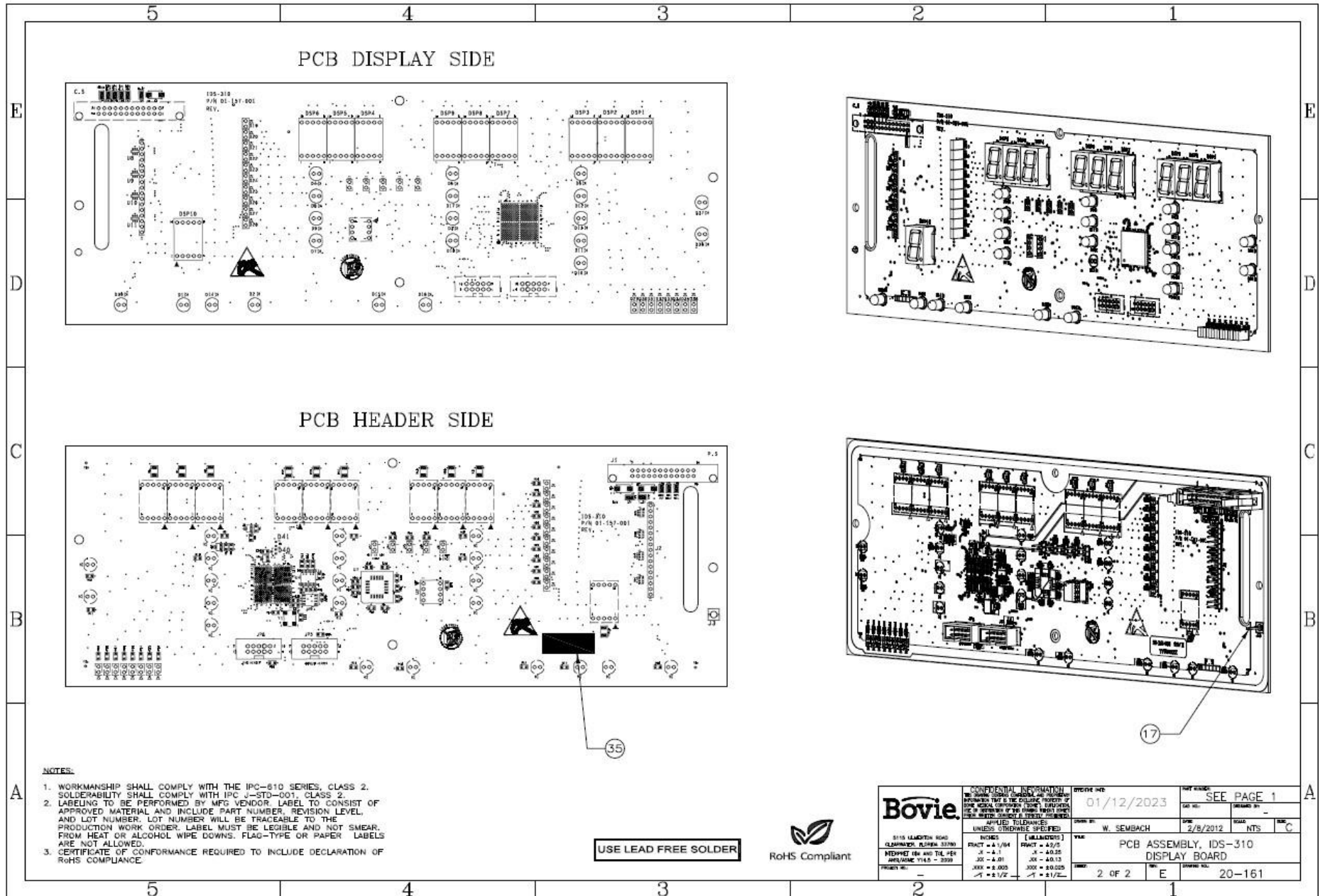

Assembly Drawing 1 Back Plate Assembly

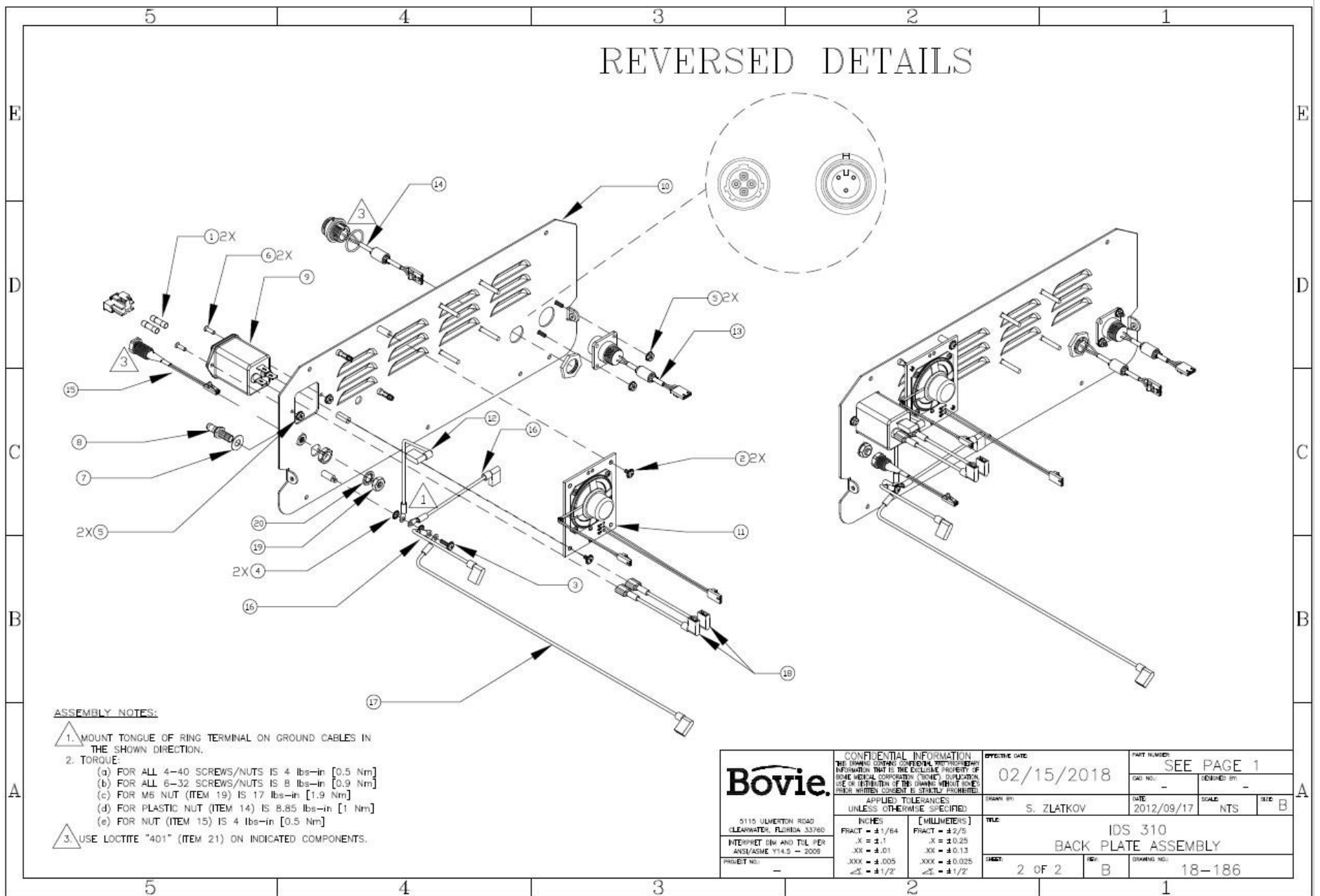

Assembly Drawing 2 Front Housing Assembly

	5	4	3	2	1																																																																																																																																																																																																																																																																																																																																								
	<table border="1" style="width: 100%; border-collapse: collapse;"> <tr> <th style="width: 10%;">REV</th> <th style="width: 60%;">DESCRIPTION</th> <th style="width: 30%;">REVISED BY/DATE</th> </tr> <tr> <td></td> <td></td> <td>B. AVRAMOV - 01/11/2018</td> </tr> <tr> <td>E</td> <td>ADDED "-003" AND "-610".</td> <td></td> </tr> </table>				REV	DESCRIPTION	REVISED BY/DATE			B. AVRAMOV - 01/11/2018	E	ADDED "-003" AND "-610".																																																																																																																																																																																																																																																																																																																																	
REV	DESCRIPTION	REVISED BY/DATE																																																																																																																																																																																																																																																																																																																																											
		B. AVRAMOV - 01/11/2018																																																																																																																																																																																																																																																																																																																																											
E	ADDED "-003" AND "-610".																																																																																																																																																																																																																																																																																																																																												
	<p>NOTES:</p> <p>1. TORQUE FOR ALL 6-32 NUTS IS 7 lbs-in (0.8 Nm).</p> <p>ASSEMBLY INSTRUCTIONS:</p> <p>A. PEEL OFF ADHESIVE BACKING ON ITEM 6 (*IMPORTANT* ALSO PEEL OFF THE SMALL PIECE OF ADHESIVE BEHIND THE FLEX CABLE.), SLIDE DISPLAY CABLE THRU SLOT IN THE UPPER HALF OF FRONT HOUSING. AFFIX ITEM 6 TO THE UPPER HALF OF FRONT HOUSING.</p> <p>B. PEEL OFF ADHESIVE BACKING ON ITEM 7 AND AFFIX TO THE LOWER HALF OF FRONT PANEL.</p> <p>C. ATTACH DISPLAY PCB (ITEM 8) WITH STANDOFFS (ITEM 2) TO FRONT HOUSING MOLDING (ITEM 4).</p> <p>D. ATTACH OVERLAY FLEX CABLE ONTO BACK OF THE DISPLAY PCB.</p>																																																																																																																																																																																																																																																																																																																																												
	<table border="1" style="width: 100%; border-collapse: collapse;"> <thead> <tr> <th colspan="10">BILL OF MATERIALS</th> </tr> <tr> <th>ITEM</th> <th colspan="8">QTY per PIN</th> <th>LWM</th> <th>PART NAME</th> <th>PART NUMBER</th> </tr> <tr> <th></th> <th>001</th> <th>002</th> <th>003</th> <th>310</th> <th>210</th> <th>335</th> <th>335</th> <th>410</th> <th>510</th> <th>610</th> <th></th> </tr> </thead> <tbody> <tr> <td>1</td> <td>4</td> <td>4</td> <td>4</td> <td>4</td> <td>4</td> <td>4</td> <td>4</td> <td>4</td> <td>4</td> <td>4</td> <td>EA</td> <td>NUT, HEX W/LOCKWASHER 6-32</td> <td>04-020-006</td> </tr> <tr> <td>2</td> <td>4</td> <td>4</td> <td>4</td> <td>4</td> <td>4</td> <td>4</td> <td>4</td> <td>4</td> <td>4</td> <td>4</td> <td>EA</td> <td>STANDOFFS FOR DISPLAY PCB</td> <td>05-040-290</td> </tr> <tr> <td>3</td> <td>0</td> <td>1</td> <td>0</td> <td>1</td> <td>1</td> <td>0</td> <td>0</td> <td>1</td> <td>1</td> <td>0</td> <td>EA</td> <td>IDS 310 CONNECTOR PANEL, O-SHAPE</td> <td>05-237-003</td> </tr> <tr> <td></td> <td>1</td> <td>0</td> <td>1</td> <td>0</td> <td>0</td> <td>1</td> <td>1</td> <td>0</td> <td>0</td> <td>0</td> <td>EA</td> <td>A3350 CONNECTOR PANEL, O-SHAPE</td> <td>05-237-004</td> </tr> <tr> <td>4</td> <td>0</td> <td>1</td> <td>0</td> <td>1</td> <td>1</td> <td>0</td> <td>0</td> <td>1</td> <td>1</td> <td>0</td> <td>EA</td> <td>IDS 310 SERIES FRONT HOUSING</td> <td>05-238-010</td> </tr> <tr> <td></td> <td>1</td> <td>0</td> <td>1</td> <td>0</td> <td>0</td> <td>1</td> <td>1</td> <td>0</td> <td>0</td> <td>1</td> <td>EA</td> <td>A3350 SERIES FRONT HOUSING</td> <td>05-238-335</td> </tr> <tr> <td>5</td> <td>1</td> <td>0</td> <td>1</td> <td>0</td> <td>0</td> <td>1</td> <td>1</td> <td>0</td> <td>0</td> <td>1</td> <td>EA</td> <td>SWITCH NON-ILLUMINATED ROUND ROCKER, RC SERIES, WHITE</td> <td>07-213-001</td> </tr> <tr> <td></td> <td>0</td> <td>1</td> <td>0</td> <td>1</td> <td>1</td> <td>0</td> <td>0</td> <td>1</td> <td>1</td> <td>0</td> <td>EA</td> <td>SWITCH NON-ILLUMINATED ROUND ROCKER, RC SERIES, BLACK</td> <td>07-213-002</td> </tr> <tr> <td></td> <td>0</td> <td>0</td> <td>0</td> <td>1</td> <td>0</td> <td>0</td> <td>0</td> <td>0</td> <td>0</td> <td>0</td> <td>EA</td> <td>OVERLAY, DISPLAY, IDS 310</td> <td>15-337-001</td> </tr> <tr> <td></td> <td>0</td> <td>0</td> <td>0</td> <td>1</td> <td>0</td> <td>0</td> <td>0</td> <td>0</td> <td>0</td> <td>0</td> <td>EA</td> <td>OVERLAY, DISPLAY, IDS 210</td> <td>15-343-001</td> </tr> <tr> <td></td> <td>0</td> <td>0</td> <td>0</td> <td>0</td> <td>0</td> <td>1</td> <td>0</td> <td>0</td> <td>0</td> <td>0</td> <td>EA</td> <td>OVERLAY, DISPLAY, A2350</td> <td>15-344-001</td> </tr> <tr> <td></td> <td>0</td> <td>0</td> <td>0</td> <td>0</td> <td>0</td> <td>1</td> <td>0</td> <td>0</td> <td>0</td> <td>0</td> <td>EA</td> <td>OVERLAY, DISPLAY, A3350</td> <td>15-346-001</td> </tr> <tr> <td></td> <td>0</td> <td>0</td> <td>0</td> <td>0</td> <td>0</td> <td>0</td> <td>0</td> <td>0</td> <td>1</td> <td>0</td> <td>EA</td> <td>OVERLAY, DISPLAY, ESU-1</td> <td>15-377-001</td> </tr> <tr> <td></td> <td>0</td> <td>0</td> <td>0</td> <td>0</td> <td>0</td> <td>0</td> <td>0</td> <td>0</td> <td>1</td> <td>0</td> <td>EA</td> <td>OVERLAY, DISPLAY, IDS 310T</td> <td>15-378-001</td> </tr> <tr> <td></td> <td>0</td> <td>0</td> <td>0</td> <td>0</td> <td>0</td> <td>0</td> <td>0</td> <td>0</td> <td>0</td> <td>1</td> <td>EA</td> <td>OVERLAY, DISPLAY TOP, APPLIED MEDICAL EM010</td> <td>15-446-001</td> </tr> <tr> <td></td> <td>0</td> <td>0</td> <td>0</td> <td>1</td> <td>1</td> <td>0</td> <td>0</td> <td>1</td> <td>1</td> <td>0</td> <td>EA</td> <td>CONNECTOR PANEL OVERLAY, IDS 310 210</td> <td>15-338-001</td> </tr> <tr> <td></td> <td>0</td> <td>0</td> <td>0</td> <td>0</td> <td>0</td> <td>1</td> <td>1</td> <td>0</td> <td>0</td> <td>0</td> <td>EA</td> <td>CONNECTOR PANEL OVERLAY, A2350/ A3350</td> <td>15-345-001</td> </tr> <tr> <td></td> <td>0</td> <td>0</td> <td>0</td> <td>0</td> <td>0</td> <td>0</td> <td>0</td> <td>0</td> <td>0</td> <td>1</td> <td>EA</td> <td>OVERLAY, BOTTOM, APPLIED MEDICAL EM010</td> <td>15-447-001</td> </tr> <tr> <td>8</td> <td>0</td> <td>0</td> <td>0</td> <td>1</td> <td>1</td> <td>1</td> <td>1</td> <td>1</td> <td>1</td> <td>1</td> <td>EA</td> <td>PCB ASSY, IDS310, DISPLAY BOARD</td> <td>20-161-001</td> </tr> <tr> <td>9</td> <td>1</td> <td>1</td> <td>1</td> <td>1</td> <td>1</td> <td>1</td> <td>1</td> <td>1</td> <td>1</td> <td>1</td> <td>EA</td> <td>PCB ASSY, IDS310 CONNECTOR PANEL O-SHAPE</td> <td>20-166-002</td> </tr> <tr> <td>10</td> <td>AR</td> <td>AR</td> <td>AR</td> <td>AR</td> <td>AR</td> <td>AR</td> <td>AR</td> <td>AR</td> <td>AR</td> <td>AR</td> <td>OZ</td> <td>LOCTITE 485 INSTANT ADHESIVE</td> <td>11-028-005</td> </tr> </tbody> </table>				BILL OF MATERIALS										ITEM	QTY per PIN								LWM	PART NAME	PART NUMBER		001	002	003	310	210	335	335	410	510	610		1	4	4	4	4	4	4	4	4	4	4	EA	NUT, HEX W/LOCKWASHER 6-32	04-020-006	2	4	4	4	4	4	4	4	4	4	4	EA	STANDOFFS FOR DISPLAY PCB	05-040-290	3	0	1	0	1	1	0	0	1	1	0	EA	IDS 310 CONNECTOR PANEL, O-SHAPE	05-237-003		1	0	1	0	0	1	1	0	0	0	EA	A3350 CONNECTOR PANEL, O-SHAPE	05-237-004	4	0	1	0	1	1	0	0	1	1	0	EA	IDS 310 SERIES FRONT HOUSING	05-238-010		1	0	1	0	0	1	1	0	0	1	EA	A3350 SERIES FRONT HOUSING	05-238-335	5	1	0	1	0	0	1	1	0	0	1	EA	SWITCH NON-ILLUMINATED ROUND ROCKER, RC SERIES, WHITE	07-213-001		0	1	0	1	1	0	0	1	1	0	EA	SWITCH NON-ILLUMINATED ROUND ROCKER, RC SERIES, BLACK	07-213-002		0	0	0	1	0	0	0	0	0	0	EA	OVERLAY, DISPLAY, IDS 310	15-337-001		0	0	0	1	0	0	0	0	0	0	EA	OVERLAY, DISPLAY, IDS 210	15-343-001		0	0	0	0	0	1	0	0	0	0	EA	OVERLAY, DISPLAY, A2350	15-344-001		0	0	0	0	0	1	0	0	0	0	EA	OVERLAY, DISPLAY, A3350	15-346-001		0	0	0	0	0	0	0	0	1	0	EA	OVERLAY, DISPLAY, ESU-1	15-377-001		0	0	0	0	0	0	0	0	1	0	EA	OVERLAY, DISPLAY, IDS 310T	15-378-001		0	0	0	0	0	0	0	0	0	1	EA	OVERLAY, DISPLAY TOP, APPLIED MEDICAL EM010	15-446-001		0	0	0	1	1	0	0	1	1	0	EA	CONNECTOR PANEL OVERLAY, IDS 310 210	15-338-001		0	0	0	0	0	1	1	0	0	0	EA	CONNECTOR PANEL OVERLAY, A2350/ A3350	15-345-001		0	0	0	0	0	0	0	0	0	1	EA	OVERLAY, BOTTOM, APPLIED MEDICAL EM010	15-447-001	8	0	0	0	1	1	1	1	1	1	1	EA	PCB ASSY, IDS310, DISPLAY BOARD	20-161-001	9	1	1	1	1	1	1	1	1	1	1	EA	PCB ASSY, IDS310 CONNECTOR PANEL O-SHAPE	20-166-002	10	AR	AR	AR	AR	AR	AR	AR	AR	AR	AR	OZ	LOCTITE 485 INSTANT ADHESIVE	11-028-005	
BILL OF MATERIALS																																																																																																																																																																																																																																																																																																																																													
ITEM	QTY per PIN								LWM	PART NAME	PART NUMBER																																																																																																																																																																																																																																																																																																																																		
	001	002	003	310	210	335	335	410	510	610																																																																																																																																																																																																																																																																																																																																			
1	4	4	4	4	4	4	4	4	4	4	EA	NUT, HEX W/LOCKWASHER 6-32	04-020-006																																																																																																																																																																																																																																																																																																																																
2	4	4	4	4	4	4	4	4	4	4	EA	STANDOFFS FOR DISPLAY PCB	05-040-290																																																																																																																																																																																																																																																																																																																																
3	0	1	0	1	1	0	0	1	1	0	EA	IDS 310 CONNECTOR PANEL, O-SHAPE	05-237-003																																																																																																																																																																																																																																																																																																																																
	1	0	1	0	0	1	1	0	0	0	EA	A3350 CONNECTOR PANEL, O-SHAPE	05-237-004																																																																																																																																																																																																																																																																																																																																
4	0	1	0	1	1	0	0	1	1	0	EA	IDS 310 SERIES FRONT HOUSING	05-238-010																																																																																																																																																																																																																																																																																																																																
	1	0	1	0	0	1	1	0	0	1	EA	A3350 SERIES FRONT HOUSING	05-238-335																																																																																																																																																																																																																																																																																																																																
5	1	0	1	0	0	1	1	0	0	1	EA	SWITCH NON-ILLUMINATED ROUND ROCKER, RC SERIES, WHITE	07-213-001																																																																																																																																																																																																																																																																																																																																
	0	1	0	1	1	0	0	1	1	0	EA	SWITCH NON-ILLUMINATED ROUND ROCKER, RC SERIES, BLACK	07-213-002																																																																																																																																																																																																																																																																																																																																
	0	0	0	1	0	0	0	0	0	0	EA	OVERLAY, DISPLAY, IDS 310	15-337-001																																																																																																																																																																																																																																																																																																																																
	0	0	0	1	0	0	0	0	0	0	EA	OVERLAY, DISPLAY, IDS 210	15-343-001																																																																																																																																																																																																																																																																																																																																
	0	0	0	0	0	1	0	0	0	0	EA	OVERLAY, DISPLAY, A2350	15-344-001																																																																																																																																																																																																																																																																																																																																
	0	0	0	0	0	1	0	0	0	0	EA	OVERLAY, DISPLAY, A3350	15-346-001																																																																																																																																																																																																																																																																																																																																
	0	0	0	0	0	0	0	0	1	0	EA	OVERLAY, DISPLAY, ESU-1	15-377-001																																																																																																																																																																																																																																																																																																																																
	0	0	0	0	0	0	0	0	1	0	EA	OVERLAY, DISPLAY, IDS 310T	15-378-001																																																																																																																																																																																																																																																																																																																																
	0	0	0	0	0	0	0	0	0	1	EA	OVERLAY, DISPLAY TOP, APPLIED MEDICAL EM010	15-446-001																																																																																																																																																																																																																																																																																																																																
	0	0	0	1	1	0	0	1	1	0	EA	CONNECTOR PANEL OVERLAY, IDS 310 210	15-338-001																																																																																																																																																																																																																																																																																																																																
	0	0	0	0	0	1	1	0	0	0	EA	CONNECTOR PANEL OVERLAY, A2350/ A3350	15-345-001																																																																																																																																																																																																																																																																																																																																
	0	0	0	0	0	0	0	0	0	1	EA	OVERLAY, BOTTOM, APPLIED MEDICAL EM010	15-447-001																																																																																																																																																																																																																																																																																																																																
8	0	0	0	1	1	1	1	1	1	1	EA	PCB ASSY, IDS310, DISPLAY BOARD	20-161-001																																																																																																																																																																																																																																																																																																																																
9	1	1	1	1	1	1	1	1	1	1	EA	PCB ASSY, IDS310 CONNECTOR PANEL O-SHAPE	20-166-002																																																																																																																																																																																																																																																																																																																																
10	AR	AR	AR	AR	AR	AR	AR	AR	AR	AR	OZ	LOCTITE 485 INSTANT ADHESIVE	11-028-005																																																																																																																																																																																																																																																																																																																																
	<table border="1" style="width: 100%; border-collapse: collapse;"> <tr> <td>APPLIED MEDICAL HOUSING ASSY.</td> <td>18-187-610</td> </tr> <tr> <td>ESU-1 FRONT HOUSING ASSY.</td> <td>18-187-510</td> </tr> <tr> <td>IDS 310T FRONT HOUSING ASSY.</td> <td>18-187-410</td> </tr> <tr> <td>A2350 FRONT HOUSING ASSY.</td> <td>18-187-235</td> </tr> <tr> <td>A3350 FRONT HOUSING ASSY.</td> <td>18-187-335</td> </tr> <tr> <td>IDS 210 FRONT HOUSING ASSY.</td> <td>18-187-210</td> </tr> <tr> <td>IDS 310 FRONT HOUSING ASSY.</td> <td>18-187-310</td> </tr> <tr> <td>APPLIED MEDICAL FRONT HOUSING PARTIAL ASSY.</td> <td>18-187-003</td> </tr> <tr> <td>IDS SERIES FRONT HOUSING PARTIAL ASSY.</td> <td>18-187-002</td> </tr> <tr> <td>AARON SERIES FRONT HOUSING PARTIAL ASSY.</td> <td>18-187-001</td> </tr> </table>				APPLIED MEDICAL HOUSING ASSY.	18-187-610	ESU-1 FRONT HOUSING ASSY.	18-187-510	IDS 310T FRONT HOUSING ASSY.	18-187-410	A2350 FRONT HOUSING ASSY.	18-187-235	A3350 FRONT HOUSING ASSY.	18-187-335	IDS 210 FRONT HOUSING ASSY.	18-187-210	IDS 310 FRONT HOUSING ASSY.	18-187-310	APPLIED MEDICAL FRONT HOUSING PARTIAL ASSY.	18-187-003	IDS SERIES FRONT HOUSING PARTIAL ASSY.	18-187-002	AARON SERIES FRONT HOUSING PARTIAL ASSY.	18-187-001																																																																																																																																																																																																																																																																																																																					
APPLIED MEDICAL HOUSING ASSY.	18-187-610																																																																																																																																																																																																																																																																																																																																												
ESU-1 FRONT HOUSING ASSY.	18-187-510																																																																																																																																																																																																																																																																																																																																												
IDS 310T FRONT HOUSING ASSY.	18-187-410																																																																																																																																																																																																																																																																																																																																												
A2350 FRONT HOUSING ASSY.	18-187-235																																																																																																																																																																																																																																																																																																																																												
A3350 FRONT HOUSING ASSY.	18-187-335																																																																																																																																																																																																																																																																																																																																												
IDS 210 FRONT HOUSING ASSY.	18-187-210																																																																																																																																																																																																																																																																																																																																												
IDS 310 FRONT HOUSING ASSY.	18-187-310																																																																																																																																																																																																																																																																																																																																												
APPLIED MEDICAL FRONT HOUSING PARTIAL ASSY.	18-187-003																																																																																																																																																																																																																																																																																																																																												
IDS SERIES FRONT HOUSING PARTIAL ASSY.	18-187-002																																																																																																																																																																																																																																																																																																																																												
AARON SERIES FRONT HOUSING PARTIAL ASSY.	18-187-001																																																																																																																																																																																																																																																																																																																																												
	<table border="1" style="width: 100%; border-collapse: collapse;"> <tr> <td rowspan="2" style="width: 30%;">Bovie</td> <td style="width: 30%;">OFFICINE DATE: 02/15/2018</td> <td style="width: 40%;">PART NUMBER: SEE ABOVE</td> </tr> <tr> <td>5115 LUMERTON ROAD CLEARWATER, FLORIDA 33760</td> <td>DESIGN BY: S. ZLATKOV</td> <td>DATE: 2012/09/17</td> <td>SCALE: NTS</td> <td>SEC: B</td> </tr> <tr> <td>PROJECT NO.: -</td> <td>TITLE: IDS 310 FRONT HOUSING ASSEMBLY</td> <td>DRAWING NO.: 18-187</td> </tr> <tr> <td colspan="2">APPLIED TOLERANCES UNLESS OTHERWISE SPECIFIED</td> <td>1 OF 1</td> </tr> <tr> <td colspan="2">INCHES [MILLIMETERS]</td> <td>E</td> </tr> <tr> <td colspan="2">FRACT = 1/64 FRACT = ±0.015</td> <td></td> </tr> <tr> <td colspan="2">.X = ±0.1 .X = ±0.25</td> <td></td> </tr> <tr> <td colspan="2">.XX = ±0.01 .XX = ±0.13</td> <td></td> </tr> <tr> <td colspan="2">.XXX = ±0.005 .XXX = ±0.025</td> <td></td> </tr> <tr> <td colspan="2">.Δ = ±1/2 .Δ = ±1/2</td> <td></td> </tr> </table>				Bovie	OFFICINE DATE: 02/15/2018	PART NUMBER: SEE ABOVE	5115 LUMERTON ROAD CLEARWATER, FLORIDA 33760	DESIGN BY: S. ZLATKOV	DATE: 2012/09/17	SCALE: NTS	SEC: B	PROJECT NO.: -	TITLE: IDS 310 FRONT HOUSING ASSEMBLY	DRAWING NO.: 18-187	APPLIED TOLERANCES UNLESS OTHERWISE SPECIFIED		1 OF 1	INCHES [MILLIMETERS]		E	FRACT = 1/64 FRACT = ±0.015			.X = ±0.1 .X = ±0.25			.XX = ±0.01 .XX = ±0.13			.XXX = ±0.005 .XXX = ±0.025			.Δ = ±1/2 .Δ = ±1/2																																																																																																																																																																																																																																																																																																											
Bovie	OFFICINE DATE: 02/15/2018	PART NUMBER: SEE ABOVE																																																																																																																																																																																																																																																																																																																																											
	5115 LUMERTON ROAD CLEARWATER, FLORIDA 33760	DESIGN BY: S. ZLATKOV	DATE: 2012/09/17	SCALE: NTS	SEC: B																																																																																																																																																																																																																																																																																																																																								
PROJECT NO.: -	TITLE: IDS 310 FRONT HOUSING ASSEMBLY	DRAWING NO.: 18-187																																																																																																																																																																																																																																																																																																																																											
APPLIED TOLERANCES UNLESS OTHERWISE SPECIFIED		1 OF 1																																																																																																																																																																																																																																																																																																																																											
INCHES [MILLIMETERS]		E																																																																																																																																																																																																																																																																																																																																											
FRACT = 1/64 FRACT = ±0.015																																																																																																																																																																																																																																																																																																																																													
.X = ±0.1 .X = ±0.25																																																																																																																																																																																																																																																																																																																																													
.XX = ±0.01 .XX = ±0.13																																																																																																																																																																																																																																																																																																																																													
.XXX = ±0.005 .XXX = ±0.025																																																																																																																																																																																																																																																																																																																																													
.Δ = ±1/2 .Δ = ±1/2																																																																																																																																																																																																																																																																																																																																													

Assembly Drawing 3 Final Assembly 1

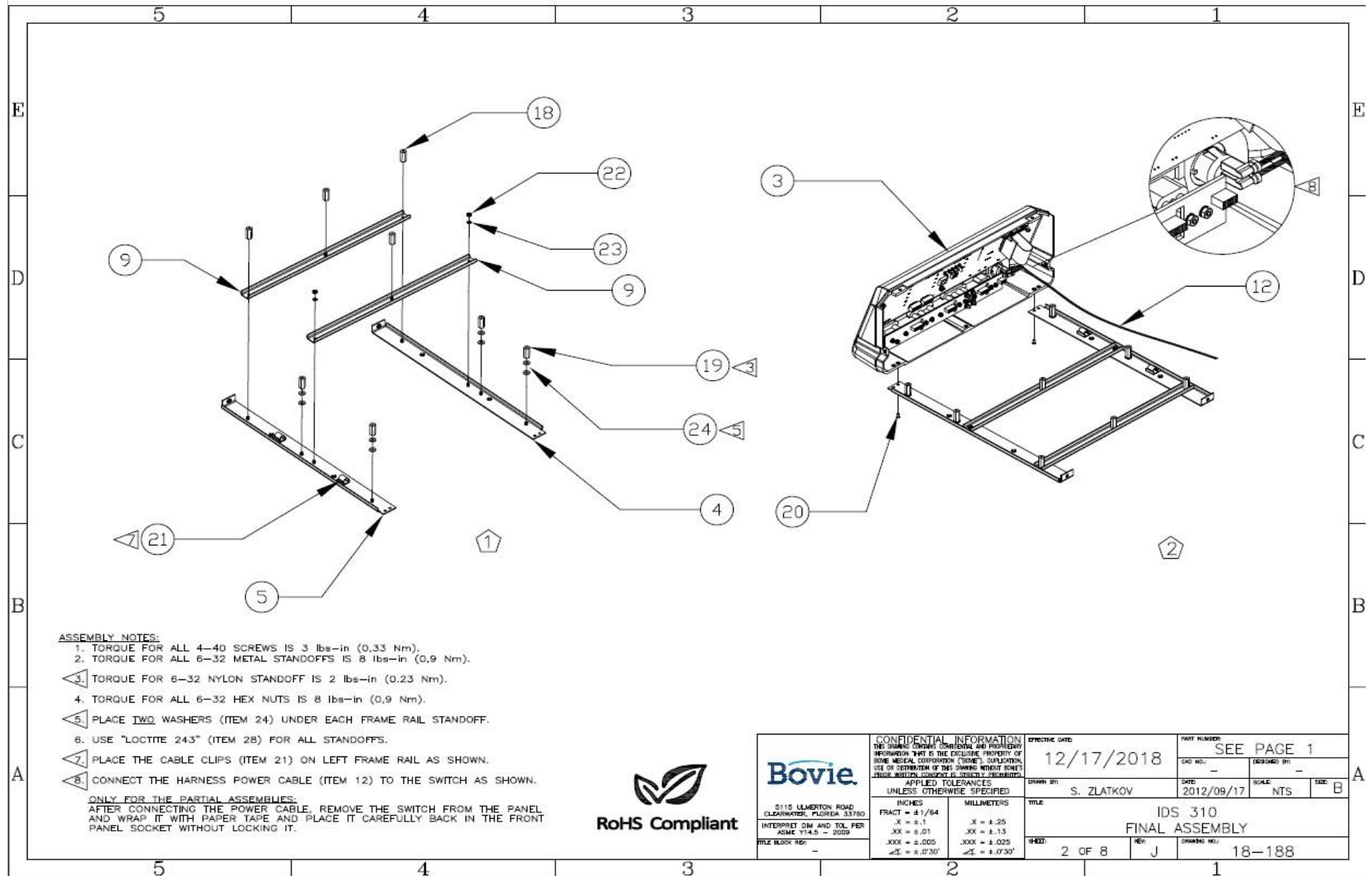

ASSEMBLY NOTES:

1. TORQUE FOR ALL 4-40 SCREWS IS 3 lbs-in (0,33 Nm).
2. TORQUE FOR ALL 6-32 METAL STANDOFFS IS 8 lbs-in (0,9 Nm).
3. TORQUE FOR 6-32 NYLON STANDOFF IS 2 lbs-in (0,23 Nm).
4. TORQUE FOR ALL 6-32 HEX NUTS IS 8 lbs-in (0,9 Nm).
5. PLACE TWO WASHERS (ITEM 24) UNDER EACH FRAME RAIL STANDOFF.
6. USE "LOCTITE 243" (ITEM 28) FOR ALL STANDOFFS.
7. PLACE THE CABLE CLIPS (ITEM 21) ON LEFT FRAME RAIL AS SHOWN.
8. CONNECT THE HARNESS POWER CABLE (ITEM 12) TO THE SWITCH AS SHOWN.

ONLY FOR THE PARTIAL ASSEMBLES:
 AFTER CONNECTING THE POWER CABLE, REMOVE THE SWITCH FROM THE PANEL AND WRAP IT WITH PAPER TAPE AND PLACE IT CAREFULLY BACK IN THE FRONT PANEL SOCKET WITHOUT LOCKING IT.



<p>5115 ULMERTON ROAD CLARKWATER, FLORIDA 33790</p> <p>INTERPRET DIM AND TOL PER ASME Y14.5 - 2009</p> <p>TITLE BLOCK REF: -</p>	<p>CONFIDENTIAL INFORMATION THIS DRAWING CONTAINS CONFIDENTIAL AND PROPRIETARY INFORMATION THAT IS THE EXCLUSIVE PROPERTY OF BOVIE MEDICAL CORPORATION ("BOVIE"). DUPLICATION, USE OR DISTRIBUTION OF THIS DRAWING WITHOUT BOVIE'S PRIOR WRITTEN CONSENT IS STRICTLY PROHIBITED.</p> <p>APPLIED TOLERANCES UNLESS OTHERWISE SPECIFIED:</p> <table border="1"> <tr> <th>INCHES</th> <th>MILLIMETERS</th> </tr> <tr> <td>FRACT = 1/64</td> <td>X = ±.25</td> </tr> <tr> <td>X = ±.1</td> <td>XX = ±.13</td> </tr> <tr> <td>XX = ±.01</td> <td>XXX = ±.025</td> </tr> <tr> <td>XXX = ±.005</td> <td>∠ = ±.030°</td> </tr> <tr> <td>∠ = ±.030°</td> <td></td> </tr> </table>	INCHES	MILLIMETERS	FRACT = 1/64	X = ±.25	X = ±.1	XX = ±.13	XX = ±.01	XXX = ±.025	XXX = ±.005	∠ = ±.030°	∠ = ±.030°		<p>EFFECTIVE DATE 12/17/2018</p> <p>DRAWN BY: S. ZLATKOV</p> <p>TITLE IDS 310 FINAL ASSEMBLY</p> <p>SHEET 2 OF 8</p> <p>REV J</p>	<p>PART NUMBER: SEE PAGE 1</p> <p>CAD NO.: -</p> <p>DATE 2012/09/17</p> <p>SCALE NTS</p> <p>SUB: B</p> <p>DRAWING NO.: 18-188</p>
	INCHES	MILLIMETERS													
FRACT = 1/64	X = ±.25														
X = ±.1	XX = ±.13														
XX = ±.01	XXX = ±.025														
XXX = ±.005	∠ = ±.030°														
∠ = ±.030°															
<p>RoHS Compliant</p>															

Assembly Drawing 4 Final Assembly 2

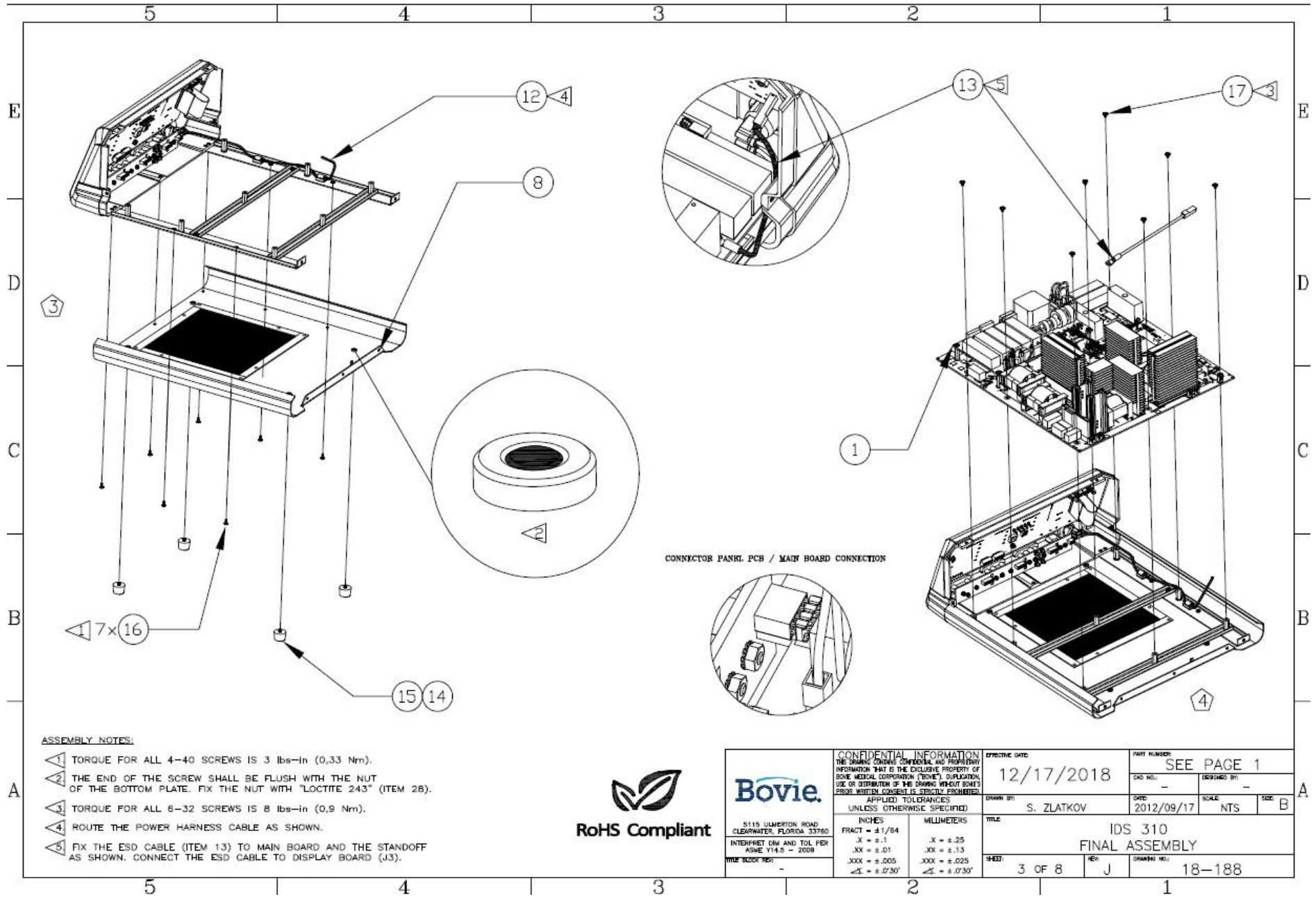

ASSEMBLY NOTES:

- ▲ TORQUE FOR ALL 4-40 SCREWS IS 3 lbs-in (0,33 Nm).
- ▲ THE END OF THE SCREW SHALL BE FLUSH WITH THE NUT OF THE BOTTOM PLATE. FIX THE NUT WITH "LOCTITE 243" (ITEM 28).
- ▲ TORQUE FOR ALL 6-32 SCREWS IS 8 lbs-in (0,9 Nm).
- ▲ ROUTE THE POWER HARNESS CABLE AS SHOWN.
- ▲ FIX THE ESD CABLE (ITEM 13) TO MAIN BOARD AND THE STANDOFF AS SHOWN. CONNECT THE ESD CABLE TO DISPLAY BOARD (J3).



<p>5115 SUMMITT ROAD CLEARWATER, FLORIDA 33760</p> <p>INTERPRET DIM AND TOL PER ASME Y14.5 - 2009</p> <p>DATE: 08/15/18</p>	<p>CONFIDENTIAL INFORMATION THE DRAWING CONTAINS CONFIDENTIAL AND PROPRIETARY INFORMATION THAT IS THE EXCLUSIVE PROPERTY OF BOWIE MEDICAL CORPORATION ("BOWIE"). REPLICATION, USE OR DISTRIBUTION OF THIS DRAWING WITHOUT BOWIE'S PRIOR WRITTEN CONSENT IS STRICTLY PROHIBITED.</p>		<p>DATE: 12/17/2018</p>	<p>PART NUMBER: SEE PAGE 1</p>											
	<p>APPLIED TOLERANCES UNLESS OTHERWISE SPECIFIED:</p> <table border="1"> <tr> <th>INCHES</th> <th>MILLIMETERS</th> </tr> <tr> <td>FRACT = ± 1/64</td> <td>.X = ± .25</td> </tr> <tr> <td>.X = ± .1</td> <td>.XX = ± .13</td> </tr> <tr> <td>.XXX = ± .005</td> <td>.XXX = ± .025</td> </tr> <tr> <td>∠ = ± 0°30'</td> <td>∠ = ± 0°30'</td> </tr> </table>		INCHES	MILLIMETERS	FRACT = ± 1/64	.X = ± .25	.X = ± .1	.XX = ± .13	.XXX = ± .005	.XXX = ± .025	∠ = ± 0°30'	∠ = ± 0°30'	<p>DESIGNED BY: -</p>	<p>DATE: 2012/09/17</p>	<p>SCALE: NTS</p>
INCHES	MILLIMETERS														
FRACT = ± 1/64	.X = ± .25														
.X = ± .1	.XX = ± .13														
.XXX = ± .005	.XXX = ± .025														
∠ = ± 0°30'	∠ = ± 0°30'														
<p>TITLE: IDS 310 FINAL ASSEMBLY</p>			<p>DRAWN BY: S. ZLATKOV</p>	<p>REV: J</p>											
<p>SHEET: 3 OF 8</p>			<p>DRAWING NO: 18-188</p>												

Assembly Drawing 5 Final Assembly 3

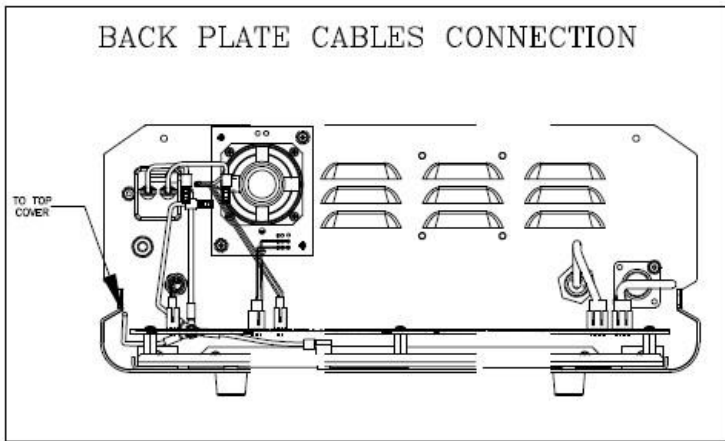
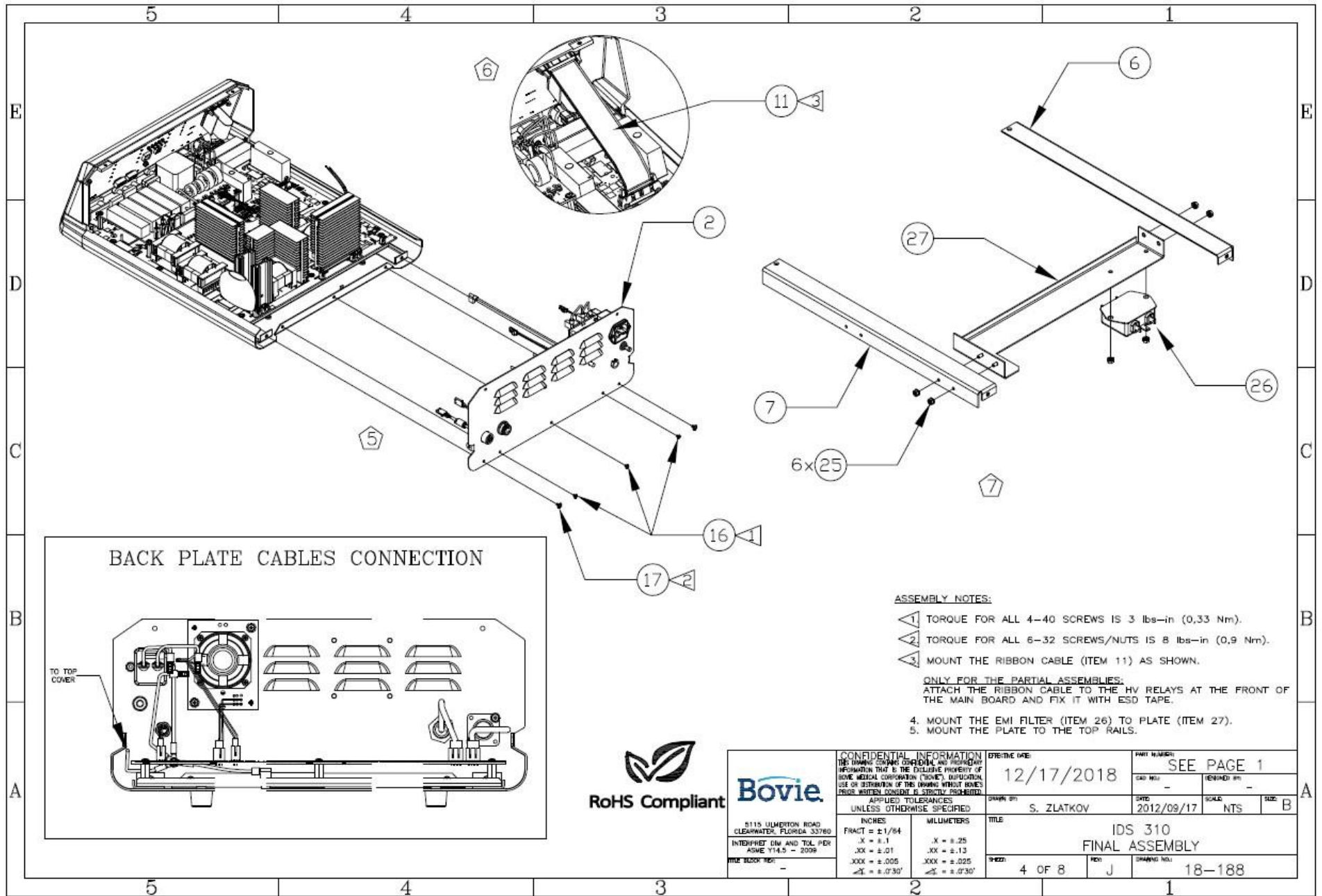

ASSEMBLY NOTES:

- ▲ TORQUE FOR ALL 4-40 SCREWS IS 3 lbs-in (0,33 Nm).
 - ▲ TORQUE FOR ALL 6-32 SCREWS/NUTS IS 8 lbs-in (0,9 Nm).
 - ▲ MOUNT THE RIBBON CABLE (ITEM 11) AS SHOWN.
- ONLY FOR THE PARTIAL ASSEMBLIES:**
 ATTACH THE RIBBON CABLE TO THE HV RELAYS AT THE FRONT OF THE MAIN BOARD AND FIX IT WITH ESD TAPE.
4. MOUNT THE EMI FILTER (ITEM 26) TO PLATE (ITEM 27).
 5. MOUNT THE PLATE TO THE TOP RAILS.



Bovie 5115 ULMERTON ROAD CLEARWATER, FLORIDA 33780 INTERPRET DIM AND TOL PER ASME Y14.5 - 2009 TITLE BLOCK REF: -	CONFIDENTIAL INFORMATION THIS DRAWING CONTAINS CONFIDENTIAL AND PROPRIETARY INFORMATION THAT IS THE EXCLUSIVE PROPERTY OF BOVIE MEDICAL CORPORATION ("BOVIE"). UNAUTHORIZED USE OR DISTRIBUTION OF THIS DRAWING WITHOUT BOVIE'S PRIOR WRITTEN CONSENT IS STRICTLY PROHIBITED.	DATE/TIME DATE: 12/17/2018	PART NUMBER: SEE PAGE 1
	APPLIED TOLERANCES UNLESS OTHERWISE SPECIFIED	DRAWN BY: S. ZLATKOV	DATE: 2012/09/17
INCHES FRACT = ±1/64 .X = ±.1 .XX = ±.01 .XXX = ±.005 ∠ = ±.030°	MILLIMETERS .X = ±.25 .XX = ±.13 .XXX = ±.025 ∠ = ±.030°	TITLE: IDS 310 FINAL ASSEMBLY	SCALE: NTS
SHEET: 4 OF 8		REV: J	DRAWING NO: 18-188

Assembly Drawing 6 Final Assembly 4

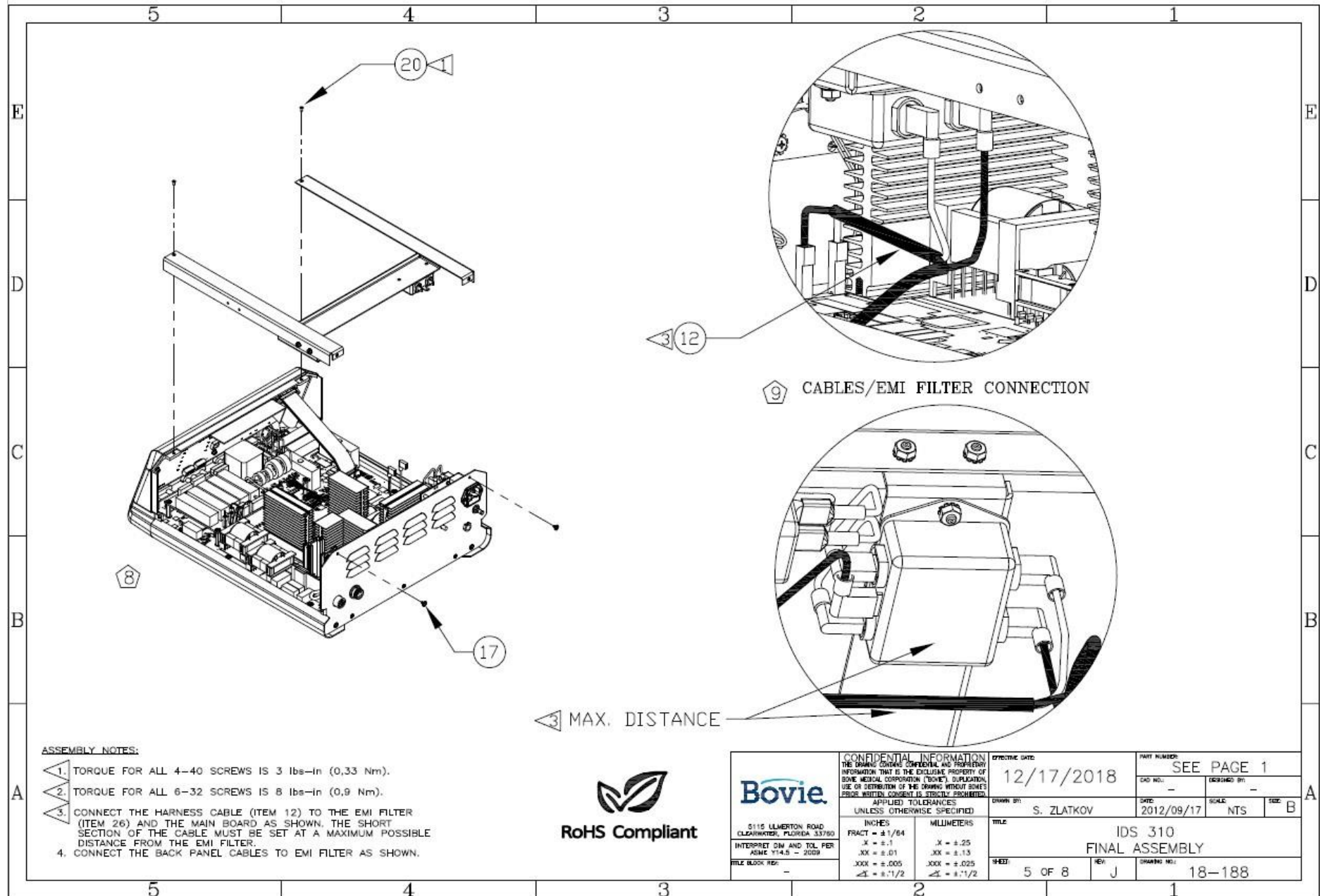

ASSEMBLY NOTES:

1. TORQUE FOR ALL 4-40 SCREWS IS 3 lbs-in (0,33 Nm).
2. TORQUE FOR ALL 6-32 SCREWS IS 8 lbs-in (0,9 Nm).
3. CONNECT THE HARNESS CABLE (ITEM 12) TO THE EMI FILTER (ITEM 26) AND THE MAIN BOARD AS SHOWN. THE SHORT SECTION OF THE CABLE MUST BE SET AT A MAXIMUM POSSIBLE DISTANCE FROM THE EMI FILTER.
4. CONNECT THE BACK PANEL CABLES TO EMI FILTER AS SHOWN.



	CONFIDENTIAL INFORMATION THE DRAWING CONTAINS CONFIDENTIAL AND PROPRIETARY INFORMATION THAT IS THE EXCLUSIVE PROPERTY OF BOVIE MEDICAL CORPORATION (BOVIE). REPRODUCTION, USE OR DISTRIBUTION OF THE DRAWING WITHOUT BOVIE'S PRIOR WRITTEN CONSENT IS STRICTLY PROHIBITED.		EFFECTIVE DATE: 12/17/2018	PART NUMBER: SEE PAGE 1				
	UNLESS OTHERWISE SPECIFIED: INCHES FRACT = ±1/64 .X = ±.1 .XX = ±.01 .XXX = ±.005 ∠ = ±1/2		MILLIMETERS .X = ±.25 .XX = ±.13 .XXX = ±.025 ∠ = ±1/2		DRAWN BY: S. ZLATKOV	DATE: 2012/09/17	SCALE: NTS	SIZE: B
5115 ULMERTON ROAD CLEARWATER, FLORIDA 33760 INTERPRET DIM AND TOL PER ASME Y14.5 - 2009		TITLE: IDS 310 FINAL ASSEMBLY		SHEET: 5 OF 8		REV: J		DRAWING NO.: 18-188

Assembly Drawing 7 Final Assembly 5

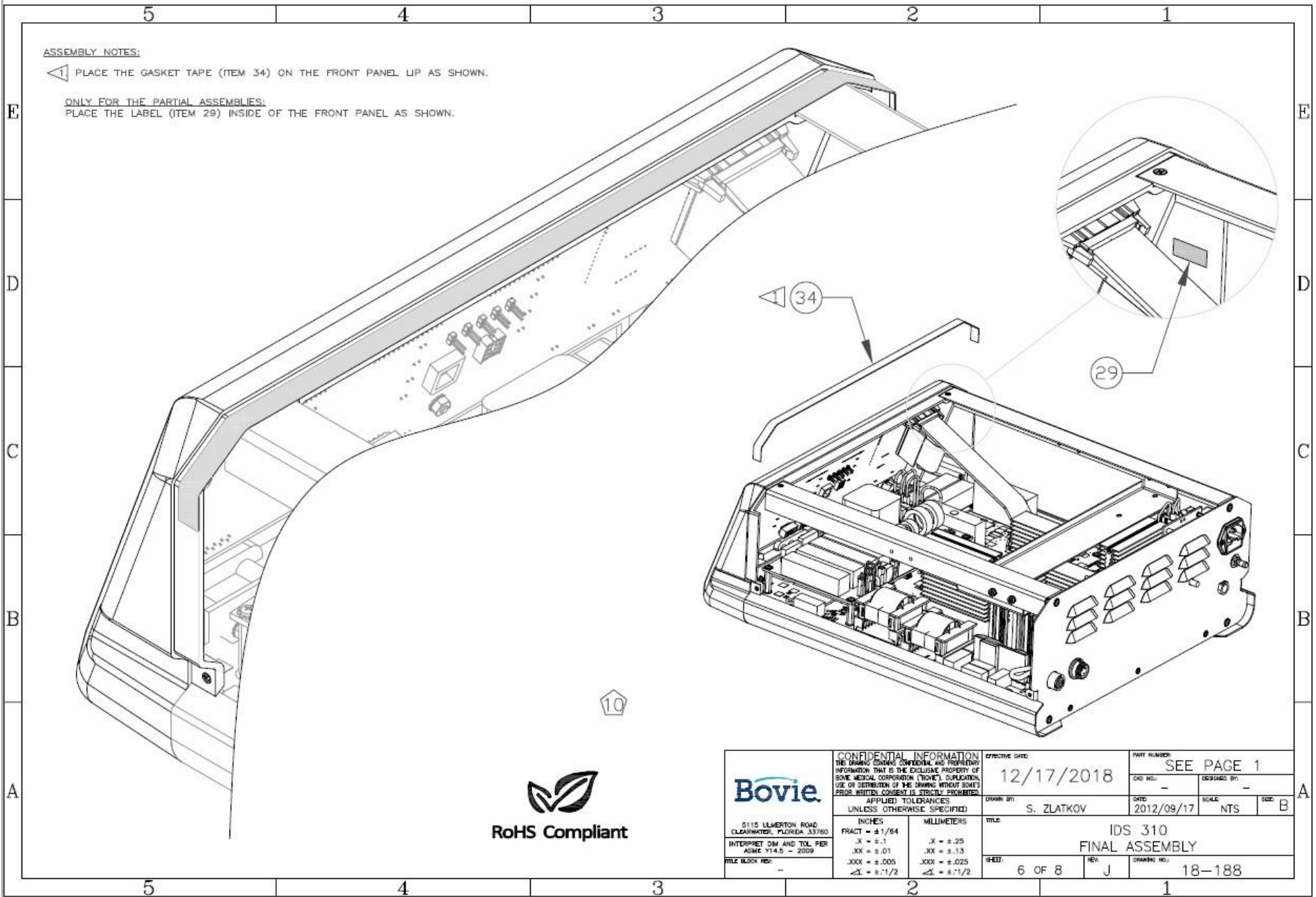

ASSEMBLY NOTES:

1 PLACE THE GASKET TAPE (ITEM 34) ON THE FRONT PANEL LIP AS SHOWN.

ONLY FOR THE PARTIAL ASSEMBLIES:
PLACE THE LABEL (ITEM 29) INSIDE OF THE FRONT PANEL AS SHOWN.

10



	<small>CONFIDENTIAL INFORMATION THIS DRAWING CONTAINS CONFIDENTIAL AND PROPRIETARY INFORMATION THAT IS THE EXCLUSIVE PROPERTY OF BOVIE MEDICAL CORPORATION ("BOVIE"). DUPLICATION, USE OR DISTRIBUTION OF THIS DRAWING WITHOUT BOVIE'S PRIOR WRITTEN CONSENT IS STRICTLY PROHIBITED.</small>		<small>EFFECTIVE DATE:</small> 12/17/2018	<small>PART NUMBER:</small> SEE PAGE 1	
	<small>APPLIED TOLERANCES UNLESS OTHERWISE SPECIFIED</small>		<small>DRAWN BY:</small> S. ZLATKOV	<small>DATE:</small> 2012/09/17	<small>SCALE:</small> NTS
<small>5115 ULLERTON ROAD CLEARWATER, FLORIDA 33760</small>	<small>INCHES</small> FRACT = ±1/64 .X = ±.1 .XX = ±.01 .XXX = ±.005 ∠ = ±.1/2	<small>MILLIMETERS</small> .X = ±.25 .XX = ±.13 .XXX = ±.025 ∠ = ±.1/2	<small>TITLE:</small> IDS 310 FINAL ASSEMBLY	<small>DRW NO.:</small> 6 OF 8	<small>REV.:</small> J
<small>INTERPRET DIM AND TOL PER ASME Y14.5 - 2009</small>	<small>TITLE BLOCK REF.:</small> -	<small>DATE:</small> 2012/09/17	<small>DATE:</small> 2012/09/17	<small>SCALE:</small> NTS	<small>SIZE:</small> B
			<small>DRWING NO.:</small> 18-188		

Assembly Drawing 8 Final Assembly 6

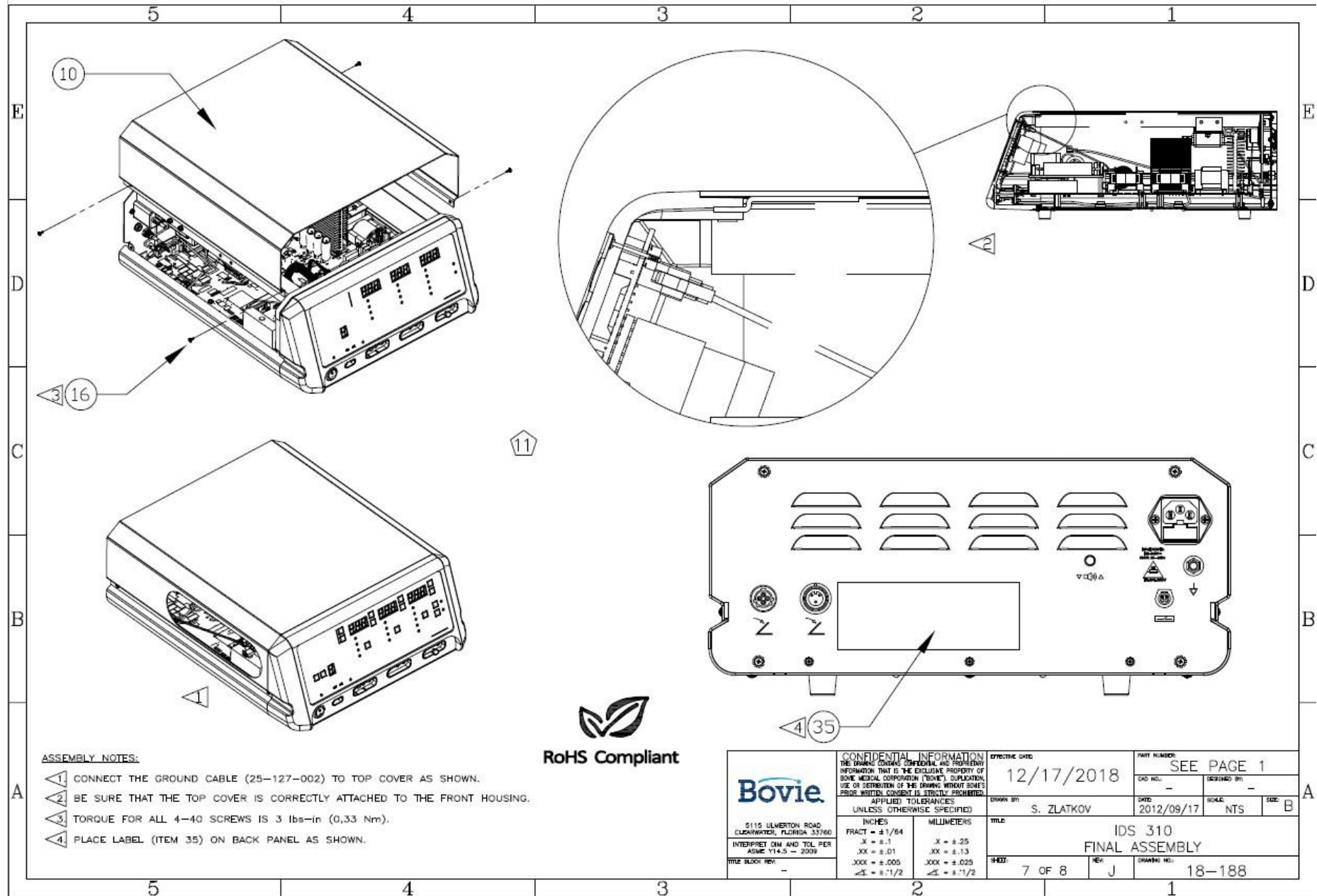

Assembly Drawing 9 Final Assembly 7

INSTRUCTIONS FOR MAKING FULL ASSEMBLY FROM PARTIAL ASSEMBLY

ASSEMBLY NOTES:

1. FOLLOWING WI-0575.
2. REMOVE THE SCREWS (ITEM 16) AND THE TOP COVER (ITEM 10) FROM PARTIAL ASSEMBLY (ITEM 30).
3. REMOVE THE FOUR SCREWS (04-020-006) FROM THE BACK SIDE OF FRONT PANEL.
4. REMOVE THE SWITCH FROM THE CONNECTOR PANEL. REMOVE THE PAPER TAPE FROM THE SWITCH.
5. REMOVE THE POLYESTER LABEL (ITEM 29) FROM THE FRONT PANEL. RECORD THE LABEL SERIAL NUMBER IN THE CORRESPONDING PRODUCTION ROUTER.
6. MOUNT THE DISPLAY BOARD (ITEM 33), DISPLAY OVERLAY (ITEM 31), CONNECTOR PANEL OVERLAY (ITEM 32) AND THE SWITCH ACCORDING TO DWG 18-187 AND WI#18-187.
7. CONNECT THE GROUND CABLE (ITEM 13) TO THE DISPLAY BOARD AS SHOWN ON PAGE 2.
8. CONNECT THE RIBBON CABLE (ITEM 11) TO THE DISPLAY BOARD AS SHOWN ON PAGE 4.
9. MOUNT THE GASKET (ITEM 34) AS SHOWN ON PAGE 6.
10. MOUNT THE TOP COVER AS SHOWN ON PAGE 7.
11. PLACE THE LABEL (ITEM 35) AS SHOWN ON PAGE 7.

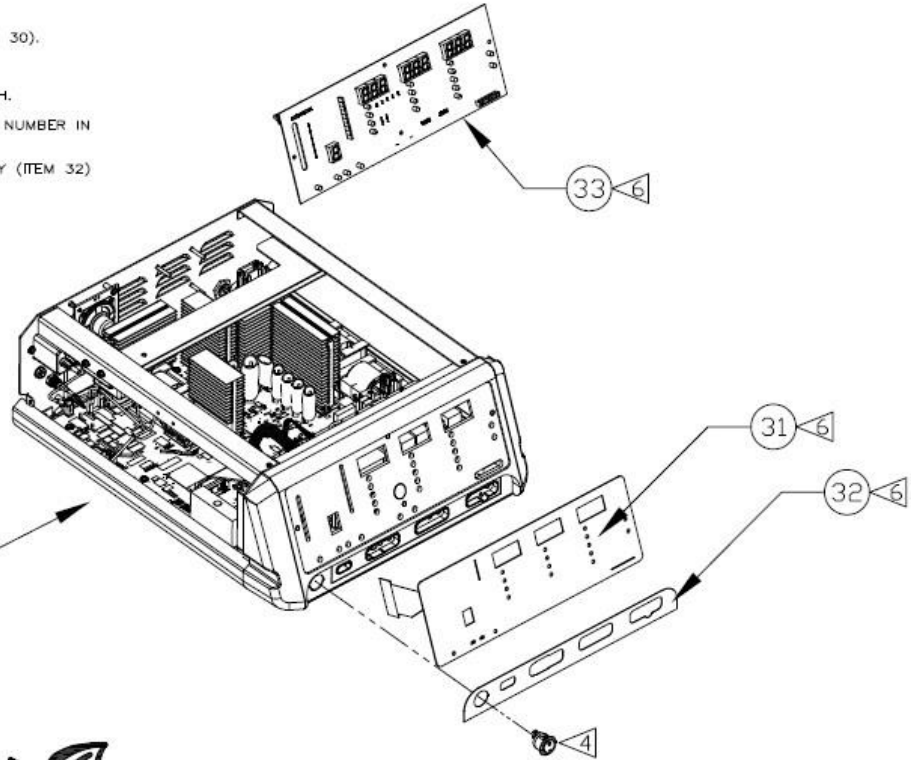

RoHS Compliant

	<small>CONFIDENTIAL INFORMATION THIS DRAWING CONTAINS CONFIDENTIAL AND PROPRIETARY INFORMATION THAT IS THE EXCLUSIVE PROPERTY OF BOVIE MEDICAL CORPORATION. THEFT, REPLICATION, USE OR DISTRIBUTION OF THIS DRAWING WITHOUT BOVIE'S PRIOR WRITTEN CONSENT IS STRICTLY PROHIBITED.</small>		<small>EFFECTIVE DATE:</small> 12/17/2018	<small>PART NUMBER:</small> SEE PAGE 1	
	<small>UNLESS OTHERWISE SPECIFIED:</small>		<small>DRAWN BY:</small> S. ZLATKOV	<small>DATE:</small> 2012/09/17	<small>SCALE:</small> NTS
<small>5115 LLMERTON ROAD CLEARWATER, FLORIDA 33780</small>	<small>INCHES</small> FRACT = 1/64 .X = ±.1 .XX = ±.01 .XXX = ±.005 -X = ±.1/2	<small>MILLIMETERS</small> .X = ±.25 .XX = ±.13 .XXX = ±.025 -X = ±.1/2	<small>TIME:</small> IDS 310 FINAL ASSEMBLY		
<small>INTERPRET DIM AND TOL PER ASME Y14.5 - 2009</small>	<small>FILE BLOCK REF:</small> -		<small>REVISION:</small> 8 OF 8	<small>REV:</small> J	<small>DRAWING NO.:</small> 18-188

CH REP

MedEnvoy Switzerland
Gotthardstrasse 28
6302 Zug
Switzerland

UK
CA
0086

UK REP

Emergo Consulting (UK) Limited
c/o Cr360 – UL International
Compass House, Vision Park Histon
Cambridge CB24 9BZ United Kingdom



Bovie®

Aspen Surgical Products, Inc
6945 Southbelt Dr. SE
Caledonia, MI 49316 USA
Phone: 616-698-7100
Toll- Free: 888-364-7004
aspensurgical.com

MC-55-231-002_5-EN
2025-02-28

EC REP

Emergo Europe
Westervoortsedijk 60
6827 AT, Arnhem
The Netherlands

CE 2797