

DALI PHANTOM

IW SUB S-100 & CI AMP-2500 DSP

APPLICATION NOTES

Introduction

These application notes describe a variety of system setup examples employing the DALI PHANTOM SUB S-100 subwoofer and the DALI PHANTOM AMP-2500 DSP amplifier in combination with other DALI Custom Install (CI) and Hi-Fi products.

The PHANTOM SUB S-100 subwoofer and DALI PHANTOM AMP-2500 DSP amplifier are extremely versatile and can be used in a large variety of situations, from modest in-wall stereo systems all the way up to ambitious multichannel home theatre installations. The examples described reflect some specific configurations that can potentially be modified to suit alternative scenarios or personal set up preferences. The following pages are intended to provide helpful insight and guidance on the many applications of the PHANTOM SUB S-100 subwoofer and AMP-2500 DSP amplifier.

Background information

Channels and Speakers

A **2.0** system (conventional stereo) consists of one left channel, one right channel.

A **2.1** system describes the addition of a subwoofer to a stereo system.

So, **2.1**, **5.1**, **7.1**, etc. refer to the number of channels installed, and, in most cases, the number of speakers and subwoofers required.

The leading digit (2, 5, 7, etc.) represent the number of full bandwidth channels where the speakers are arrayed in a horizontal plane, while the second digit .1 (or .2) represents the subwoofer channel(s).

In immersive systems such as Dolby Atmos or DTS-X that incorporate height channels, a further digit is added to specify the number of height channel speakers. For example, **7.1.4** describes a system comprising seven horizontal plane speakers, one subwoofer and four height channel speakers.

Subwoofer Channels

The subwoofer channel provides either low frequency support to the main left and right channels, or the reproduction of the LFE (Low Frequency Effects) channel when encoded multichannel encoded material (Dolby Surround, Dolby Atmos, DTS, etc.) is appropriately decoded.

Note: A configuration that employs a subwoofer simply to support the main left and right channels is known as a 'bass managed' system.

Some home theatre systems enable the connection of a second subwoofer. In these cases, if the two subwoofers are playing separate subwoofer signals, the configuration is referred to as **5.2** or **7.2** channel systems.

Note: It is possible to have multiple subwoofers playing the same channel. In this case, the system would still be referred to as a .1 subwoofer setup.

Height Channels

Multichannel immersive audio systems such as Dolby Atmos or DTS-X employ height speakers located above the listeners (or sometimes installed to radiate upwards so that their output reflects off the ceiling). These systems are represented by a further channel digit; **5.1.X**, for example, where the X indicates the number of height speakers. **5.1.4**, **7.1.2** and **7.1.4** are the most commonly found configurations.



DALI PHANTOM SUB S-100 & CI AMP-2500 DSP

APPLICATION NOTES

2.1/2.2 Channel System

A **2.1** channel setup consists of one left channel, one right channel (stereo) and a subwoofer (LFE or bass managed).

A **2.2** channel setup consists of one left channel, one right channel (stereo) and two subwoofers (LFE or bass managed).

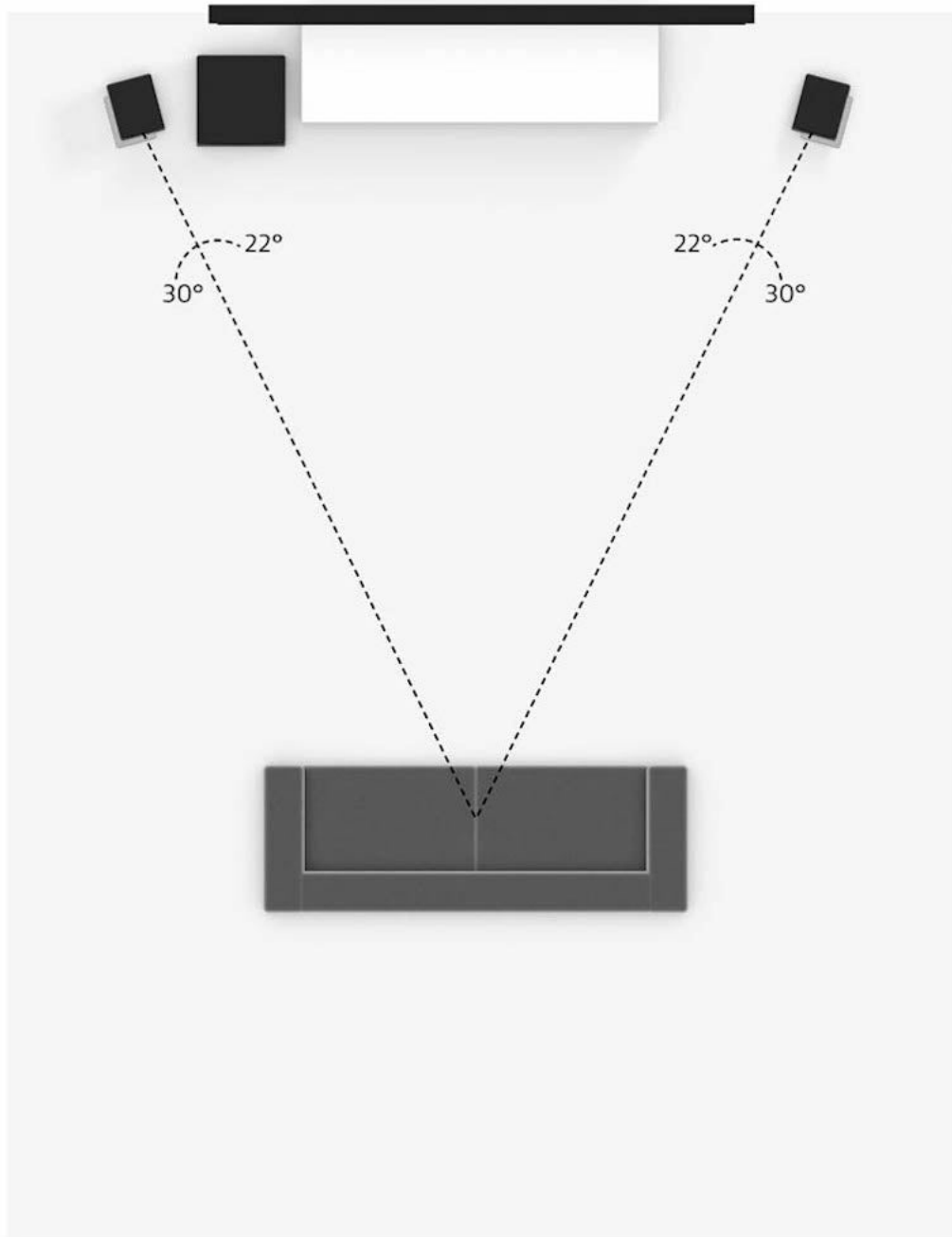

DALI PHANTOM SUB S-100 & CI AMP-2500 DSP

APPLICATION NOTES

5.1 Channel System

A **5.1** channel setup is represented by five horizontal plane channels and one subwoofer:

Left, right, centre, two surround and a subwoofer (LFE or bass managed).

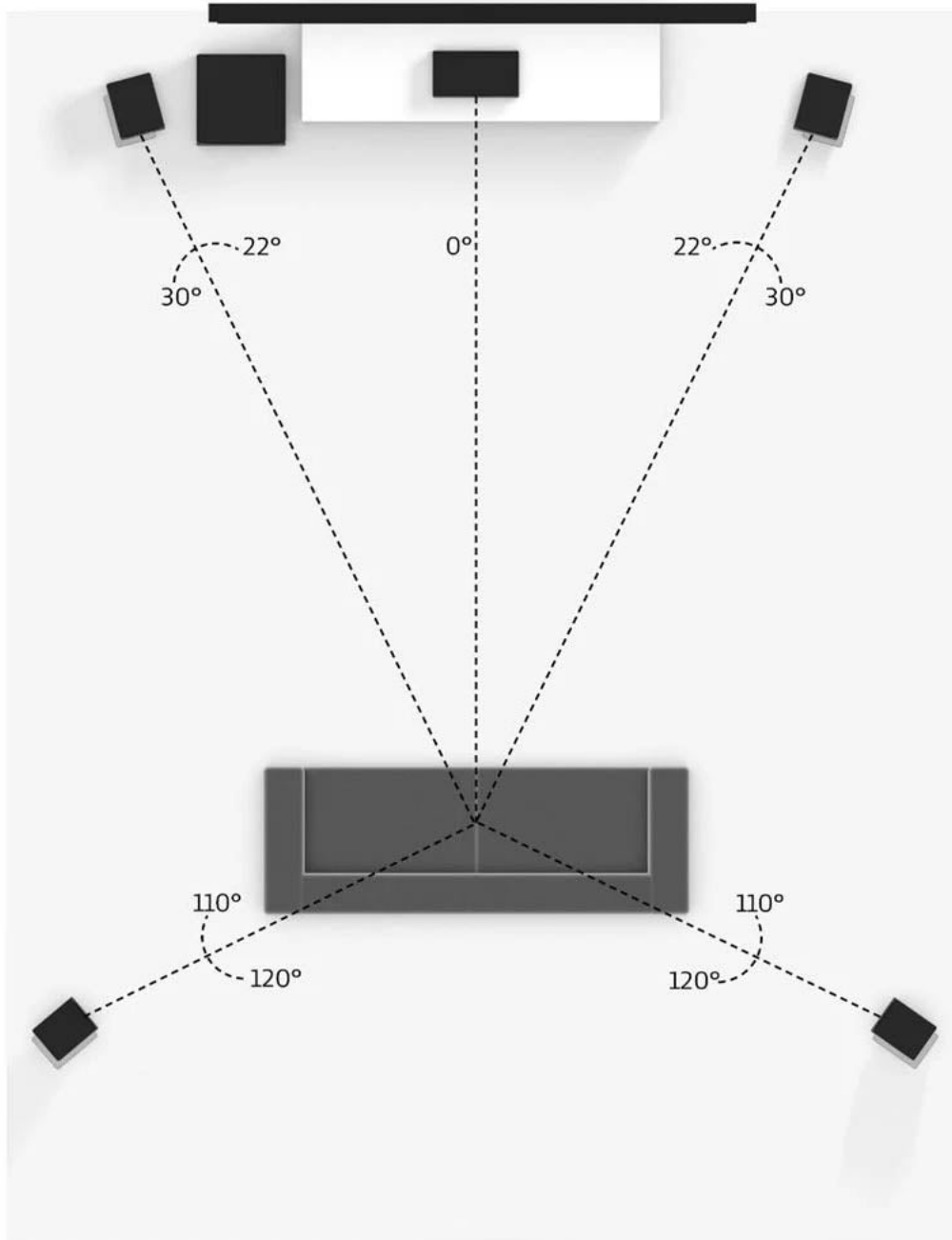

IN ADMIRATION OF MUSIC

DALI PHANTOM SUB S-100 & CI AMP-2500 DSP

APPLICATION NOTES

7.1 Channel System

A 7.1 channel setup is represented by seven horizontal plane channels and one subwoofer:

Left, right, centre, two surround, two rear surround and one subwoofer (LFE or bass managed)

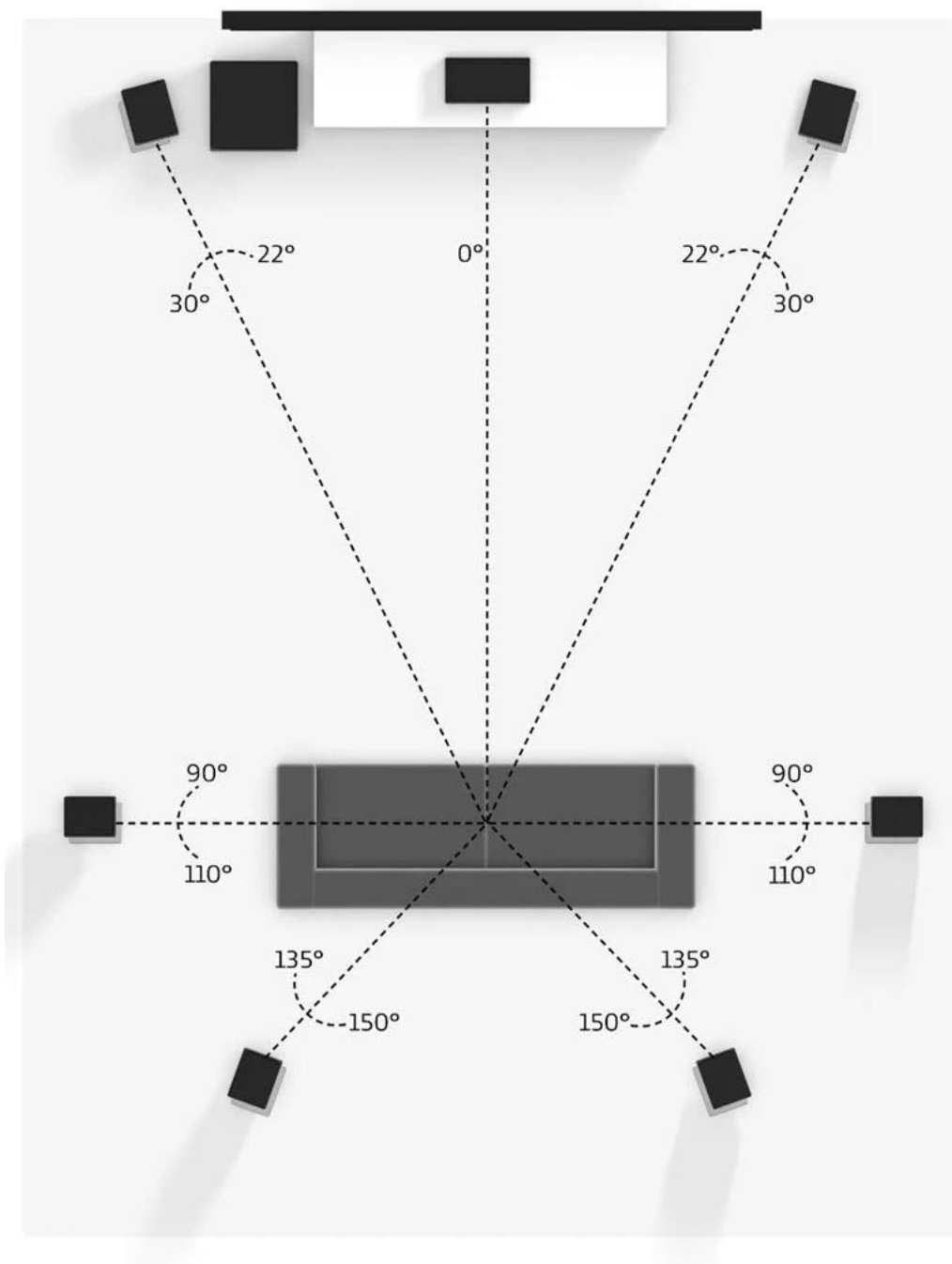

IN ADMIRATION OF MUSIC

DALI PHANTOM SUB S-100 & CI AMP-2500 DSP

APPLICATION NOTES

7.1.4 Channel System

A **7.1.4** channel setup is used for immersive formats with height speakers, such as Dolby Atmos or DTS-X, and is represented by seven horizontal channels, a subwoofer and four height channels:

Left, right, centre, two surround, two surround rear, subwoofer (LFE or bass managed), two height front and two height rear.

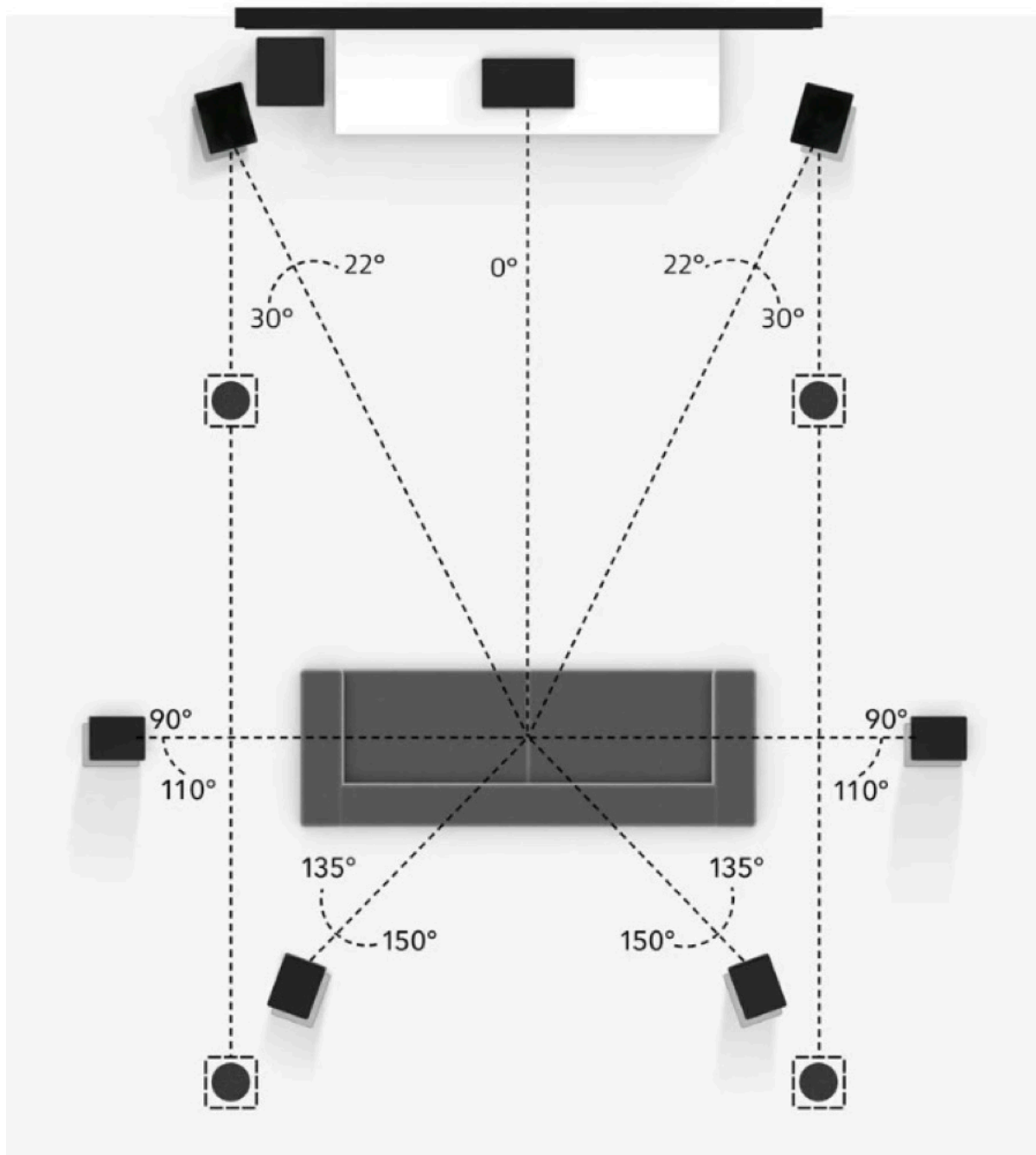

DALI PHANTOM SUB S-100 & CI AMP-2500 DSP

APPLICATION NOTES

Setting up a PHANTOM AMP-2500 DSP

PHANTOM AMP-2500 amplifiers are by default configured for use with (one to four) SUB S-100 subwoofer(s).

Home Theatre / LFE setup:

To install a SUB S-100 and AMP-2500 DSP, first connect the LFE/subwoofer output of the system AVR (Audio/Visual Receiver)/processor to the amplifier Input Channel 1. Next, connect the SUB S-100 subwoofer(s) to the AMP-2500 DSP speaker outputs. These connections are illustrated in the diagram.

1 x Subwoofer (LFE .1)

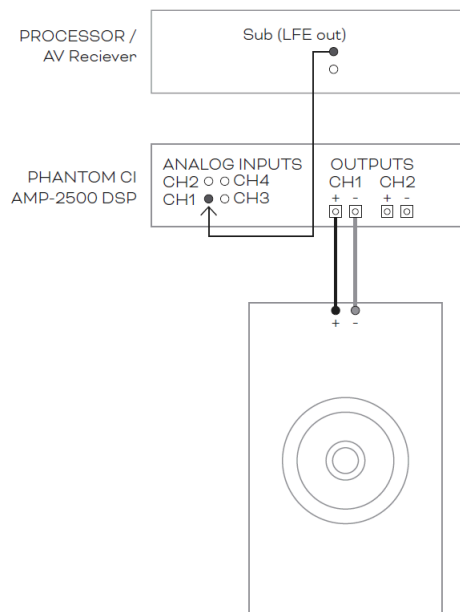

2 x Subwoofer (LFE .1)

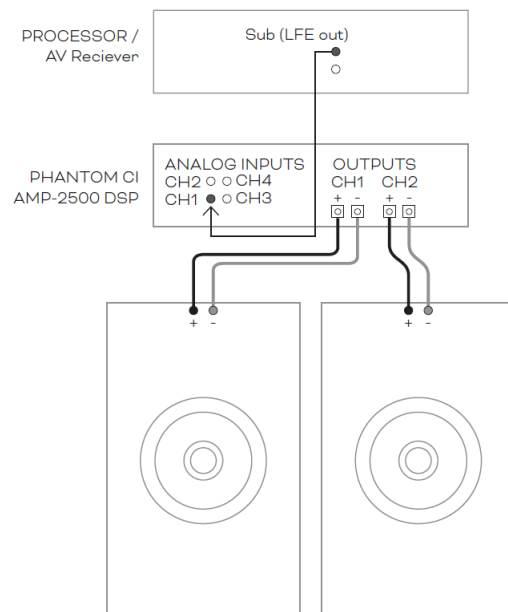

4 x Subwoofer (LFE .1)

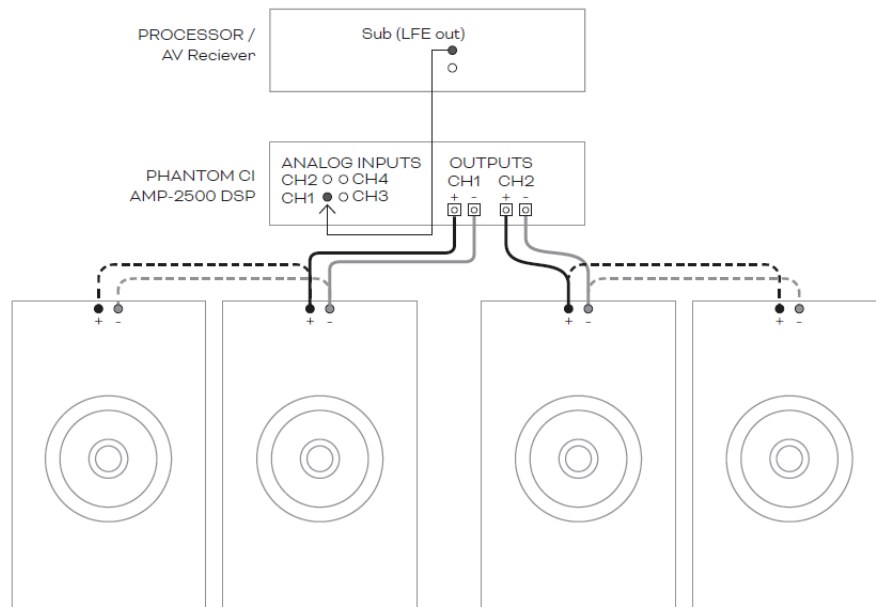

DALI PHANTOM SUB S-100 & CI AMP-2500 DSP

APPLICATION NOTES

Stereo setup:

If using the SUB S-100 and AMP-2500 in a stereo setup (2.1), connect the main speakers to the stereo amplifier left and right outputs then connect the AMP-2500 and SUB-S-100 to the stereo amplifier sub/pre-out line output(s).

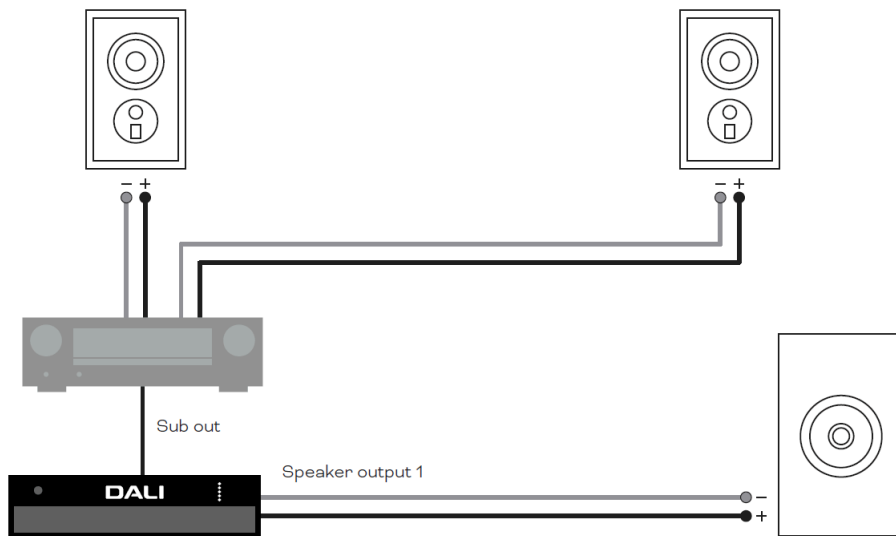

DALI PHANTOM SUB S-100 & CI AMP-2500 DSP

APPLICATION NOTES

Setting up a PHANTOM AMP-2500 DSP

Plug-and play operation:

The default configuration of the AMP-2500 DSP includes the appropriate filters, signal routing and DSP functions required for the SUB S-100 to work correctly. It is not possible to use an alternative power amplifier with the SUB S-100 subwoofer. All that is required for installation is to connect the amplifier and subwoofer to an AVR or Processor.

See the SUB S-100 and AMP-2500 DSP Quick Start Guides and Installation Manuals for more specific instructions on connections. These are available for download from the DALI website.

Configuring the AMP-2500 DSP for use with alternative speakers.

The AMP-2500 DSP amplifier is by default configured with DSP filter characteristics appropriate for the SUB S-100 subwoofer. However, it can also be configured with filter characteristics appropriate for alternative speakers, such as PHANTOM M or PHANTOM S in-wall models, or used in a conventional, unfiltered mode. In the latter mode, the AMP-2500 DSP can be used to drive any loudspeaker that does not require specific filter parameters. AMP-2500 DSP configuration files can be downloaded from the DALI website and the AMP-2500 DSP Installation Manual includes instructions on their installation and deletion.

Additional AMP-2500 DSP Configuration.

Although the AMP-2500 DSP Amp Configurator Web Interface provides multiple options to customise functions such as gain, equalisation and compression, however we strongly recommended that any adjustment of the LFE/subwoofer channel is done in the first instance in the AVR or Processor if possible.

If there is no alternative but to adjust AMP-2500 DSP configuration parameters, this can be done in the AMP-2500 DSP Amp Configurator Interface. To access the AMP-2500 DSP Configurator Interface connect a computer, tablet or smartphone to the AMP-2500 DSP WiFi access point and adjust the configuration parameters as required.

Connection and operation the AMP-2500 DSP Configurator is described in the AMP-2500 DSP Installation Manual.

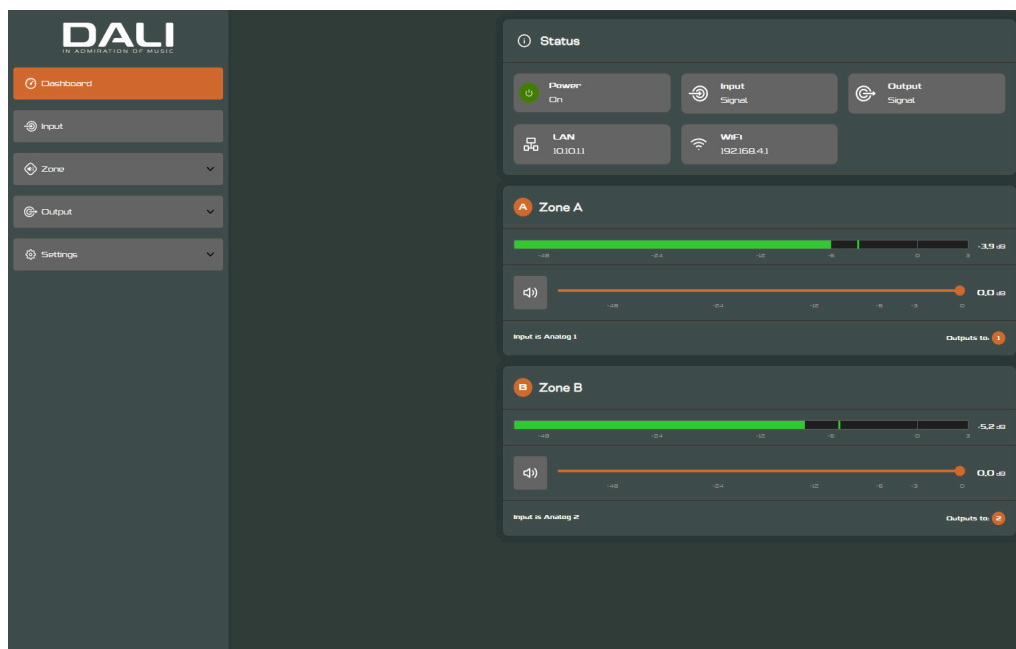

DALI PHANTOM SUB S-100 & CI AMP-2500 DSP

APPLICATION NOTES

Application Examples – Home Theatre/Surround Sound

DALI PHANTOM S-series In-wall Home Theatre (5.2)

Description:

This example shows a true 5.2 channel high-end home theatre system, based on our flagship PHANTOM S-280 front and centre channels. These are accompanied by two in-wall mounted SUB S-100 subwoofers handling the LFE + Main stereo channels, and two DALI PHANTOM K-80 in-ceiling speakers for the surround channels. Everything is driven by the AMP-2500 DSP amplifiers with the appropriate configuration presets to suit the both the subwoofers and the main speakers. Surround decoding and DSP is handled by a surround-sound processor/pre-amplifier.

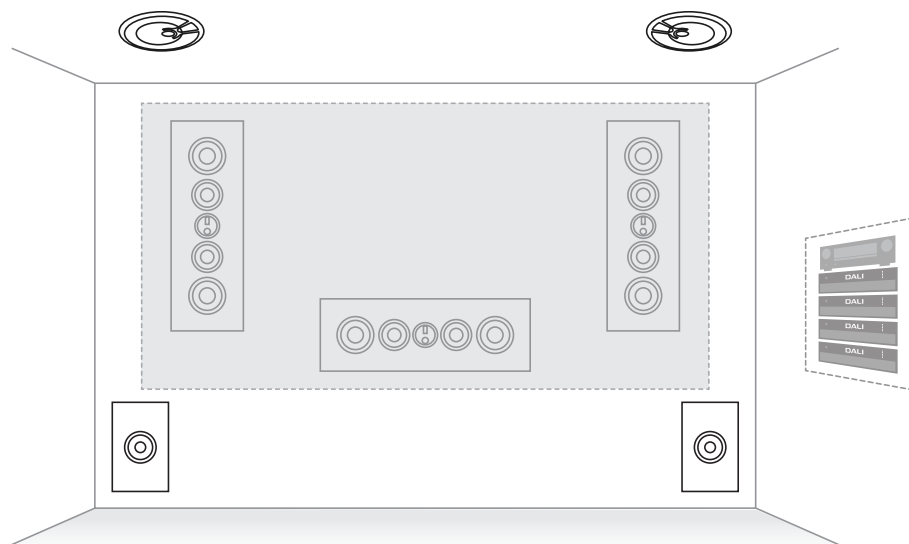

Channels:

Front Left (FL): DALI PHANTOM S-280
Centre (C): DALI PHANTOM S-280
Front Right (FR): DALI PHANTOM S-280
Surround Left (SL): DALI PHANTOM K-80
Surround Right (SR): DALI PHANTOM K-80
Sub/LFE (SW 1+2): 2x DALI PHANTOM SUB S-100
Amplifiers: DALI PHANTOM AMP-2500 DSP
Processor: Surround processor/pre-amp

Speakers:

DALI Parts List	
DALI Model	Quantity
DALI PHANTOM S-280	3
DALI PHANTOM K-80	2
DALI PHANTOM SUB S-100	2
DALI PHANTOM AMP-2500 DSP	4



DALI PHANTOM SUB S-100 & CI AMP-2500 DSP

APPLICATION NOTES

Application Examples – Home Theatre/Surround Sound

Immersive DALI PHANTOM S-series Home Theatre (5.2.2)

Description:

Extending the previous example with immersive audio support, this setup is a 5.2.2 channel high-end home theatre system with height speakers for immersive audio formats such as Dolby Atmos or DTS-X.

In this example, the flagship DALI PHANTOM S-280 is employed for front and centre channels with the PHANTOM S-180 employed for the surround channels. These are accompanied by 2x2 in-wall mounted SUB S-100 subwoofers handling the LFE + Main stereo channel, and two DALI PHANTOM K-80 in-ceiling speakers for the left and right height channels. All channels are driven by AMP-2500 amplifiers with the appropriate configuration presets and settings to suit both the subwoofers and main speakers and surround speakers. Surround decoding and DSP is handled by a surround-sound processor/pre-amplifier with immersive audio support.

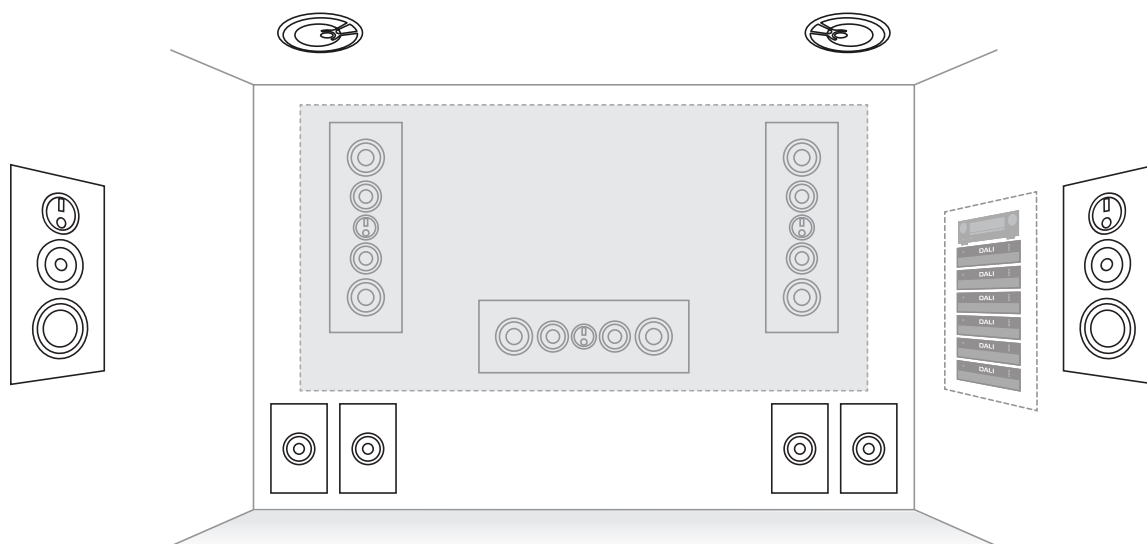

Channels:

Front Left (FL): DALI PHANTOM S-280

Centre (C): DALI PHANTOM S-280

Front Right (FR): DALI PHANTOM S-280

Surround Left (SL): DALI PHANTOM S-180

Surround Right (SR): DALI PHANTOM S-180

Top Left (TL): DALI PHANTOM K-80

Top Right (TR): DALI PHANTOM K-80

LFE Sub. Left: DALI PHANTOM SUB S-100 (SW 1+2)

LFE Sub. Right: DALI PHANTOM SUB S-100 (SW 3+4)

Amplifiers: DALI PHANTOM AMP-2500 DSP

Processor: Surround processor/pre-amp with immersive audio support.

Speakers:

DALI Parts List

DALI Model	Quantity
DALI PHANTOM S-280	3
DALI PHANTOM S-180	2
DALI PHANTOM K-80	2
DALI PHANTOM SUB S-100	4
DALI PHANTOM AMP-2500 DSP	6

DALI

IN ADMIRATION OF MUSIC

DALI PHANTOM SUB S-100 & CI AMP-2500 DSP

APPLICATION NOTES

Application Examples - Home Theatre/Surround Sound

Reference DALI PHANTOM S-series Home Theatre (7.1.4)

Description:

This setup reflects the DALI custom installation home theatre demonstration room at the DALI headquarters and showroom in Nørager, Denmark.

It is the DALI take on an ultimate immersive DALI home theatre system, and consists of PHANTOM S 280/180 front, centre and surround channels,

PHANTOM K series height channels, and no less than eight SUB S-100 subwoofers for the LFE channel. This is an extremely powerful and high-performance system driven by eight AMP-2500 amplifiers and connected to a high-end surround-sound processor/pre-amplifier with immersive audio support.

All the speakers and subwoofers on the front wall can be obscured behind an acoustically transparent projector screen.

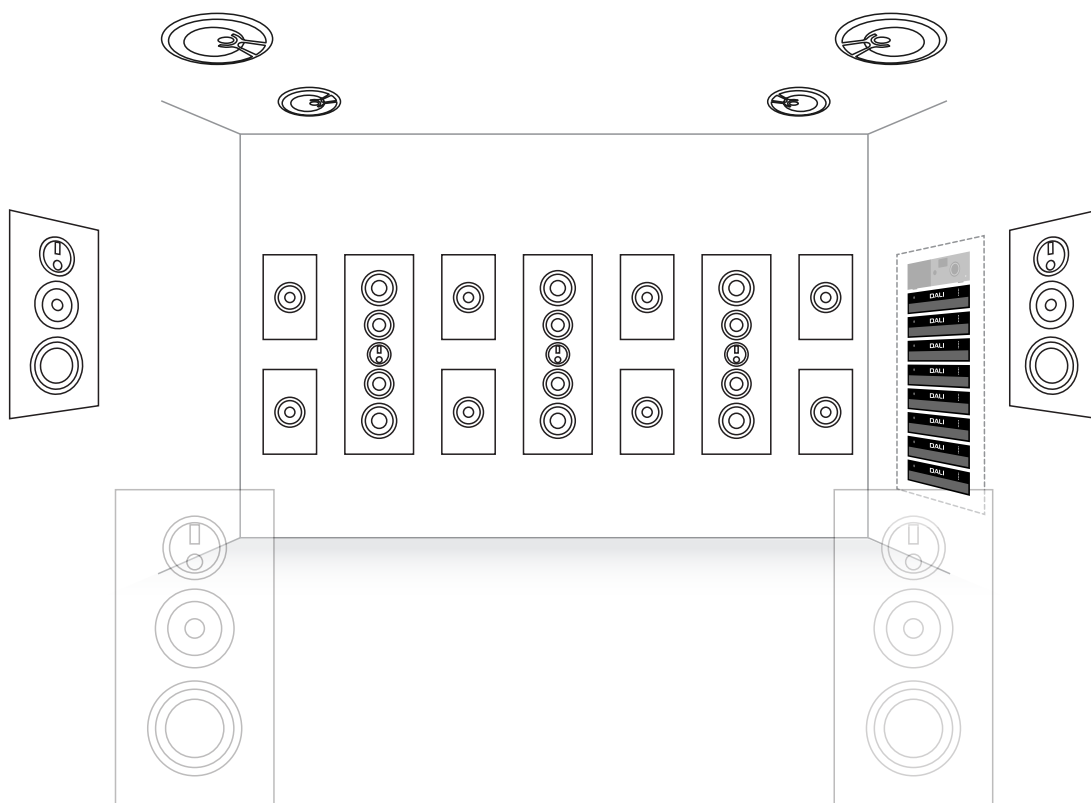

DALI PHANTOM SUB S-100 & CI AMP-2500 DSP

APPLICATION NOTES

Application Examples - Home Theatre/Surround Sound

DALI Reference System Speaker Channel Layout

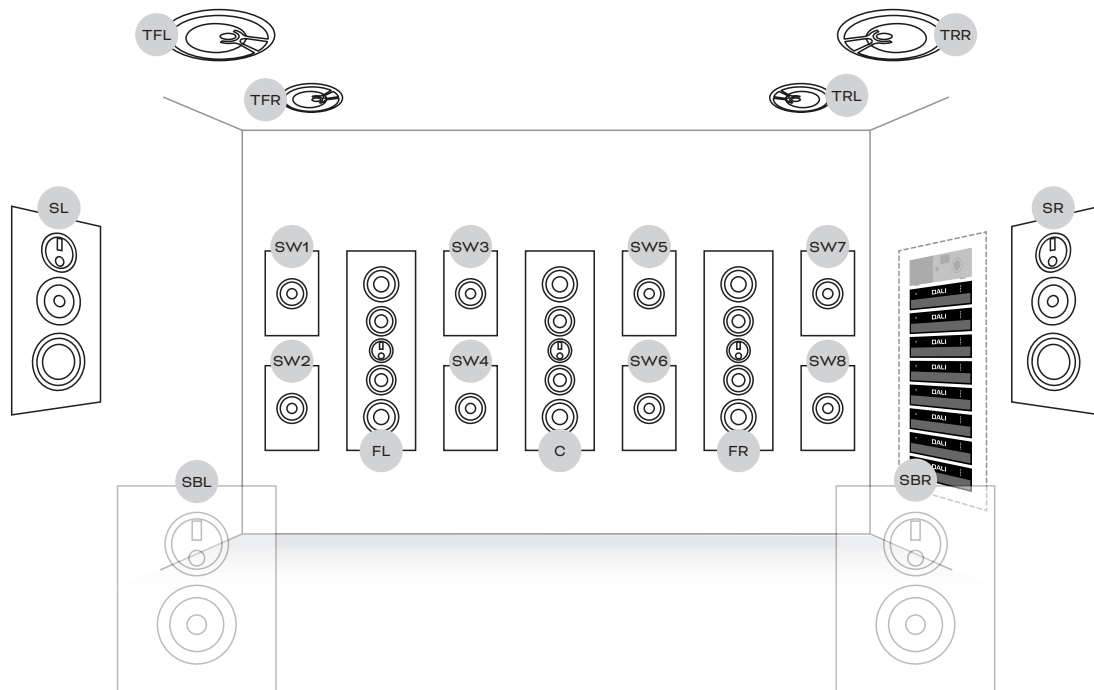

DALI Reference System Amplifier Channel Layout



IN ADMIRATION OF MUSIC

DALI PHANTOM SUB S-100 & CI AMP-2500 DSP

APPLICATION NOTES

Application Examples – Home Theatre/Surround Sound

DALI Reference System Speaker Channel Layout

Channels:**Speakers:**

Front Left (FL): DALI PHANTOM S-280
Centre (C): DALI PHANTOM S-280
Front Right (FR): DALI PHANTOM S-280
Surround Left (SL): DALI PHANTOM S-180
Surround Right (SR): DALI PHANTOM S-180
Surround Back Left: DALI PHANTOM S-180 (SBL)
Surround Back Right: DALI PHANTOM S-180 (SBR)
Top Front Left (TFL): DALI PHANTOM K-60
Top Front Right (TFR): DALI PHANTOM K-60
Top Rear Left (TRL): DALI PHANTOM K-80
Top Rear Right (TRR): DALI PHANTOM K-80
LFE Sub. 1 - 8: DALI PHANTOM SUB S-100 (SW 1 - 8)
Amplifier 1 - 8: DALI PHANTOM AMP-2500 DSP
Processor: High-end Surround Processor

DALI Parts List	
DALI Model	Quantity
DALI PHANTOM S-280	3
DALI PHANTOM S-180	4
DALI PHANTOM K-80	2
DALI PHANTOM K-60	2
DALI PHANTOM SUB S-100	8
DALI PHANTOM AMP-2500 DSP	8
High-end Surround Processor	1



DALI PHANTOM SUB S-100 & CI AMP-2500 DSP

APPLICATION NOTES

Application Examples – Distributed Sound

In-ceiling stereo system with in-wall subwoofer (2.1)

Description:

This example employs four DALI PHANTOM K-80 in-ceiling speakers for distributed sound in a room accompanied by a SUB S-100 in-wall subwoofer.

A popular installation in kitchens, dining areas or large living rooms where sound coverage of the entire room is required with the added low-end response of a subwoofer. All installed discreetly into the ceiling and walls.

This system employs one AMP-2500 DSP to drive the ceiling speakers and another to drive the subwoofer.

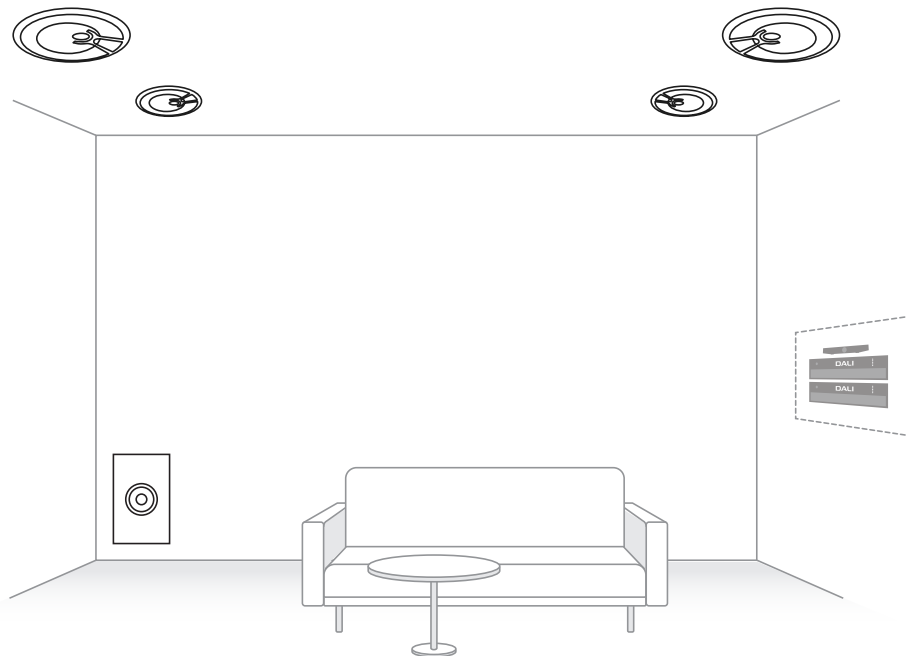

Channels:

Ceiling Left (L):

Ceiling Right (R):

Subwoofer (SW):

Amplifier (L/R):

Amplifier (SW):

Music source:

Speakers:

2x DALI PHANTOM K-80

2x DALI PHANTOM K-80

DALI PHANTOM SUB S-100

DALI PHANTOM AMP-2500 DSP

DALI PHANTOM AMP-2500 DSP
(SUB S-100 preset)

Wireless music streamer

DALI Parts List	
DALI Model	Quantity
DALI PHANTOM K-80	4
DALI PHANTOM SUB S-100	1
DALI PHANTOM AMP-2500 DSP	2



DALI PHANTOM SUB S-100 & CI AMP-2500 DSP

APPLICATION NOTES

Application Examples – Stereo

In-wall stereo CI system (2.1)

Description:

The SUB S-100 is the perfect in-wall partner for the PHANTOM M series in-wall speakers.

This example employs the PHANTOM M-375 as front left and right speakers, driven by the AMP-2500 DSP with the appropriate configuration preset. A single in-wall mounted SUB S-100 is dedicated to extend and support the low-frequency bandwidth of the system – The SUB S-100 is driven by an AMP-2500 DSP using its default configuration preset.

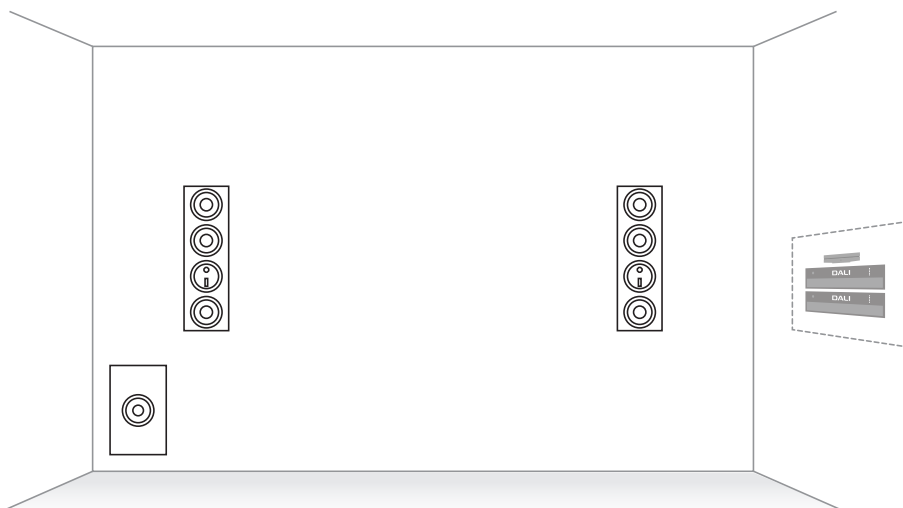

Channels:

- Front Left (FL):
Front Right (FR):
Subwoofer (SW):
Amplifier (FL/FR):
Amplifier (SW):
Music source:

Speakers:

- DALI PHANTOM M-375
DALI PHANTOM M-375
DALI PHANTOM SUB S-100
DALI PHANTOM AMP-2500 DSP
(M-375 preset)
DALI PHANTOM AMP-2500 DSP
(SUB S-100 preset)
Wireless music streamer

DALI Parts List	
DALI Model	Quantity
DALI PHANTOM M-375	2
DALI PHANTOM SUB S-100	1
DALI PHANTOM AMP-2500 DSP	2



DALI PHANTOM SUB S-100 & CI AMP-2500 DSP

APPLICATION NOTES

Application Examples – Stereo

DALI Hi-Fi stereo system with on-wall subwoofer (2.1)

Description:

The SUB S-100 can be used to extend and support the low frequency bandwidth of high performance stand mount or floor-stand stereo speakers, without taking up precious floor space.

This example uses OPTICON 6 MK2 as front left and right speakers, driven by a stereo integrated amplifier. The on-wall SUB S-100 is driven by the AMP-2500, connected to the sub or preamp output of the integrated amplifier.

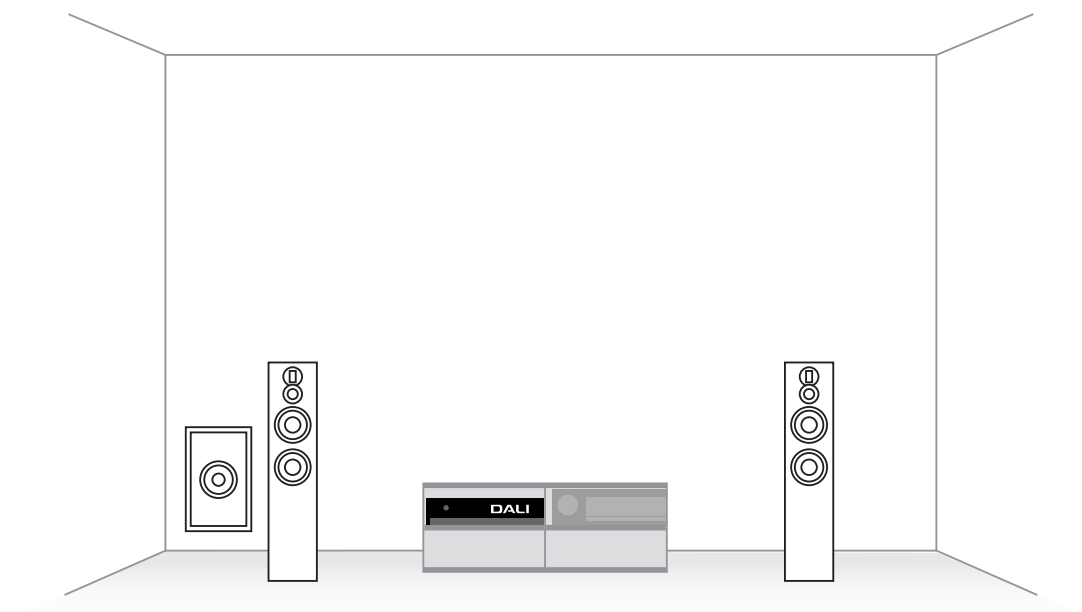

Channels:

Front Left (FL):

Front Right (FR):

Subwoofer (SW):

Amplifier (FL/FR):

Amplifier (SW):

Speakers:

DALI OPTICON 6 MK2

DALI OPTICON 6 MK2

DALI PHANTOM SUB S-100

2 channel stereo integrated streaming amplifier with sub out

DALI PHANTOM AMP-2500 DSP (SUB S-100 preset)

DALI Parts List

DALI Model	Quantity
DALI OPTICON 6 MK2	2
DALI PHANTOM SUB S-100	1
DALI PHANTOM AMP-2500 DSP	1
DALI S-80 On-Wall Frame	1



DALI PHANTOM SUB S-100 & CI AMP-2500 DSP

APPLICATION NOTES

Application Examples – Stereo

DALI High End stereo system with on-wall subs (2.2)

Description:

The SUB S-100's brilliant performance enables it to be used with high-end speakers as well.

This example uses two SUB S-100's configured as left and right subwoofers, extending and supporting the low frequency bandwidth of the DALI EPICON 2 high-end stand mount speakers. The EPICON 2 speakers are driven by a high-end stereo integrated amplifier. The in-wall SUB S-100s are driven by one AMP-2500 DSP, connected to the stereo preamp output of the integrated amplifier.

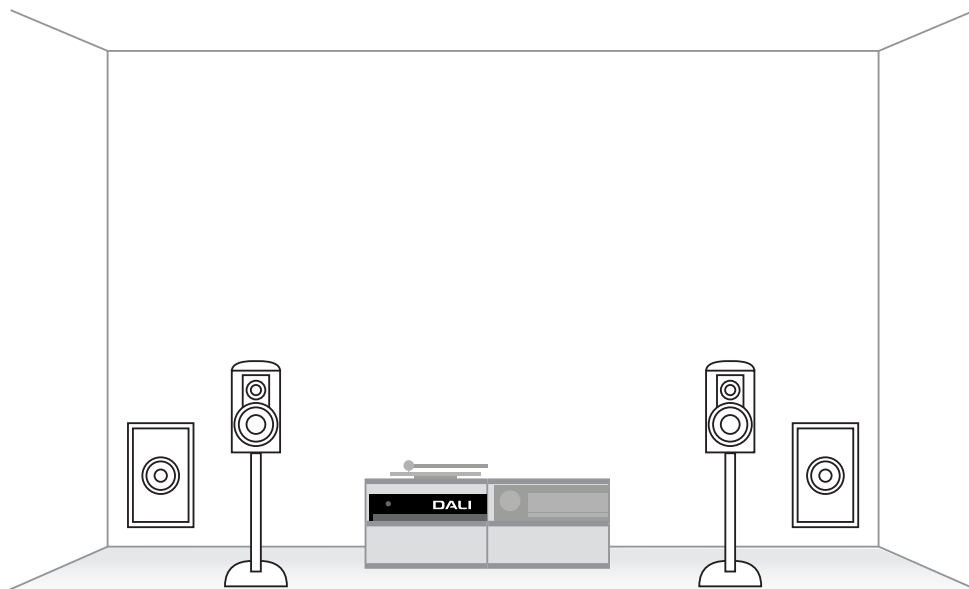

Channels:

Front Left (FL):

DALI EPICON 2

Front Right (FR):

DALI EPICON 2

Subwoofer:
(SW 1 + 2)

2 x DALI PHANTOM SUB S-100

Amplifier (FL/FR):

2 channel high-end stereo
integrated streaming amplifier
with sub out

Amplifier (SW):

DALI PHANTOM AMP-2500 DSP
(SUB S-100 preset)

Music Source:

High-end turntable

Speakers:

DALI Parts List	
DALI Model	Quantity
DALI EPICON 2	2
DALI EPICON 2 STAND	2
DALI PHANTOM SUB S-100	2
DALI PHANTOM AMP-2500 DSP	1
DALI S-80 On-Wall Frame	2



DALI PHANTOM SUB S-100 & CI AMP-2500 DSP

APPLICATION NOTES

Application Examples – Stereo

On-wall stereo CI system with stereo subwoofers (2.2)

Description:

The SUB S-100 is the perfect in-wall partner for the PHANTOM S series in-wall speakers.

This example employs the PHANTOM S-80 as front left and right speakers, driven by the AMP-2500 DSP with the appropriate configuration preset. Two SUB S-100s support and extend the low frequency bandwidth of the PHANTOM S-80s driven by a second AMP-2500 DSP using its default configuration preset.

Both the PHANTOM S-80 speakers and SUB S-100 subwoofers are mounted in S-80 on-wall frames. On-wall frames provide much of the installation benefits of in-wall mounting but without the necessity to create wall apertures. They are especially useful in situations where solid walls are present.

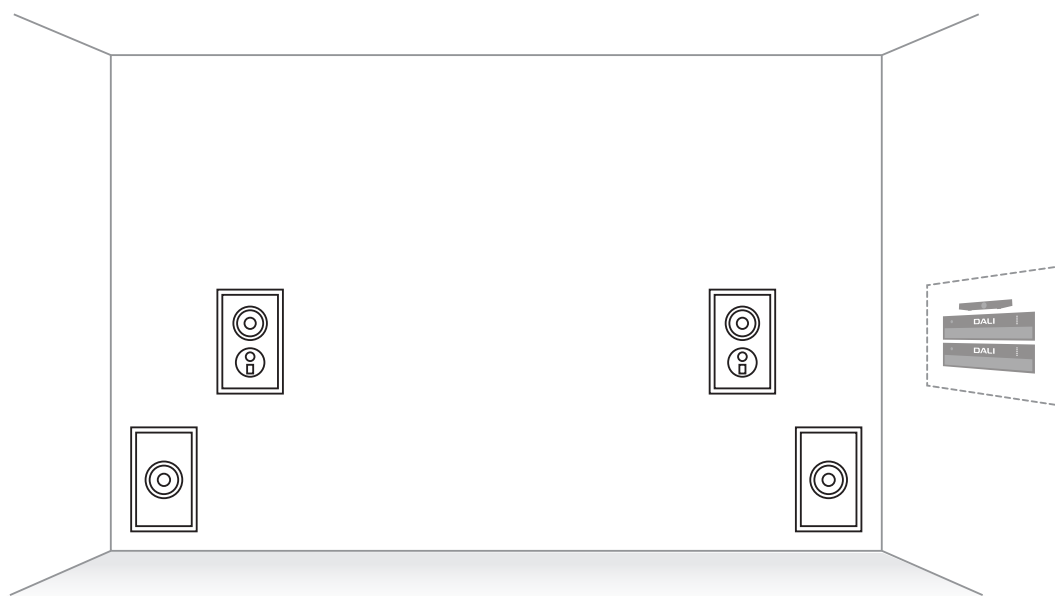

Channels:

Front Left (FL):

DALI PHANTOM S-80

Front Right (FR):

DALI PHANTOM S-80

Subwoofer

2x DALI PHANTOM SUB S-100

(SW 1+2):

Amplifier (FL/FR):

DALI PHANTOM AMP-2500
DSP (S-80 preset)

Amplifier (SW):

DALI PHANTOM AMP-2500
DSP (SUB S-100 preset)

Music source:

Wireless music streamer

Speakers:

DALI Parts List

DALI Model	Quantity
DALI PHANTOM S-80	2
DALI PHANTOM SUB S-100	2
DALI PHANTOM AMP-2500 DSP	2
DALI S-80 On-Wall Frame	4

