

---

# GREENWORKS

## COMMERCIAL

40V BRUSHLESS CHAINSAW  
GS 110

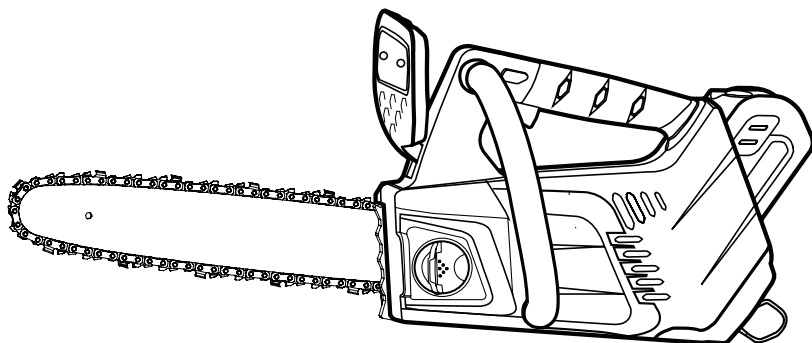

Intertek  
3091488

Owner's Manual  
**TOLL-FREE HELPLINE: 1-855-470-4267**  
[www.greenworkscommercial.com](http://www.greenworkscommercial.com)

---

 Read all safety rules and instructions carefully before operating this tool.

# CONTENTS

---

Contents .....	2
Product Specifications .....	2
Safety Information .....	3
Symbols .....	7
Know Your Chainsaw .....	9
Assembly .....	10
Operation .....	13
Maintenance .....	20
Environmentally Safe Battery Disposal .....	27
Troubleshooting .....	28
Warranty .....	30
Exploded View .....	32
Part List .....	33

## PRODUCT SPECIFICATIONS

---

### 40V CORDLESS CHAINSAW

Type .....	Cordless
Motor .....	40V Brushless
Bar Length .....	10" (254 mm)
Chain Pitch .....	1/4" LP (6.35 mm)
Chain Gauge .....	.050" (1.27 mm)
Chain Type .....	25AP058X(Oregon)
Guide Bar Type .....	100SDAA041(Oregon)
Drive Links .....	58
Oil Tank Capacity .....	120 ml
Unit Weight (Without Battery) .....	5.3 lbs. (2.4 kg)
Unit Weight (With 2.5Ah Battery) .....	7.5 lbs. (3.4 kg)



# SAFETY INFORMATION

---

## GENERAL POWER TOOL SAFETY WARNINGS

---

### **⚠ WARNING**

**Read all safety warnings and all instructions.** Failure to follow the warnings and instructions may result in electric shock, fire and/or serious injury.

---

Save all warnings and instructions for future reference.

The term “power tool” in all of the warnings listed below refers to your mains-operated (corded) power tool or battery-operated (cordless) power tool.

### **WORK AREA SAFETY**

- **Keep the working area clean and well lit.** Cluttered or dark areas invite accidents.
- **Do not operate power tools in explosive atmospheres, such as in the presence of flammable liquids, gases or dust.** Power tools create sparks which may ignite the dust or fumes.
- **Keep children and bystanders away while you are using the tool.** Distractions can cause you to lose control.

### **ELECTRICAL SAFETY**

- **Do not expose power tools to the rain or damp conditions.** Water penetrating a power tool will increase the risk of electric shock.
- **Avoid body contact with earthed or grounded surfaces such as pipes, radiators, ranges and refrigerators.** There is an increased risk of electric shock if your body is earthed or grounded.

### **PERSONAL SAFETY**

- **Stay alert, watch what you are doing and use common sense when using the tool. Do not use a tool when you are tired or under the influence of drugs, alcohol or medication.** A moment of inattention while operating power tools may result in serious personal injury.
- **Use personal protective equipment. Always wear eye protection.** Safety equipment such as dust masks, non-slip safety shoes, helmets or acoustic protection used in appropriate conditions will reduce the risk of injury.
- **Prevent unintentional starting.** Ensure the switch is in the off-position before connecting to power source and/or battery pack, picking up or carrying the tool. Carrying power tools with your finger on the switch or plugging in power tools that have the switch on invites accidents.
- **Remove any adjusting key or wrench before turning the power tool on.** A wrench left attached to a rotating part can cause injury.
- **Do not overreach.** Keep proper footing and balance at all times. This enables better control of the power tool in unexpected situations.
- **Dress appropriately. Do not wear loose clothing or jewellery. Keep hair, clothing and gloves away from moving parts.** Loose clothing, jewellery or long hair can get caught in moving parts.

### **POWER TOOL USE AND CARE**

# SAFETY INFORMATION

---

- **Do not force the power tool. Use the correct chain saw for your application.** The correct chain saw will do the job better and safer at the rate for which it was designed.
- **Do not use the power tool if the switch does not turn it on and off.** Any power tool that cannot be controlled with the switch is dangerous and must be repaired.
- **Disconnect the battery pack from the power tool before making any adjustments, changing accessories, or storing power tools.** Such preventive safety measures reduce the risk of starting the power tool accidentally.
- **Store idle power tools out of the reach of children and do not allow persons unfamiliar with the power tool or these instructions to operate the power tool.** Power tools are dangerous in the hands of untrained users. Power tools are dangerous for inexperienced users.
- **Maintain power tools.** Check for misalignment or binding of moving parts, breakage of parts and any other condition that may affect the power tool's operation. If damaged, have the power tool repaired before use. Many accidents are caused by poorly maintained power tools.
- **Keep cutting tools sharp and clean.** Properly maintained cutting tools with sharp cutting edges are less likely to bind and are easier to control.
- **Use the power tool, accessories and tool bits etc.** in accordance with these instructions, taking into account the working conditions and the work to be performed. Use of the power tool for operations different from those intended could result in a hazardous situation.

## BATTERY TOOL USE AND CARE

- **Recharge only with the charger specified by the manufacturer.** A charger that is suitable for one type of battery pack may create a risk of fire when used with another battery pack.
- **Use power tools only with specifically designated battery packs.** Use of any other battery packs may create a risk of injury and fire.
- **When battery pack is not in use, keep it away from other metal objects like paper clips, coins, keys, nails, screws, or other small metal objects that can make a connection from one terminal to another.** Shorting the battery terminals together may cause burns or a fire.
- **Under abusive conditions, liquid may be ejected from the battery, avoid contact.** If contact accidentally occurs, flush with water. If liquid contacts eyes, additionally seek medical help. Liquid ejected from the battery may cause irritation or burns.

## SERVICE

- **Have your power tool serviced by a qualified repair person using only identical replacement parts.** This will ensure that the safety of the power tool is maintained.

## CHAINSAW SAFETY WARNINGS

- **Keep all parts of the body away from the saw chain when the chainsaw is operating. Before you start the chainsaw, make sure the saw chain is not contacting anything.** A moment of inattention while operating chainsaws may cause entanglement of your clothing or body with the saw chain.
- **Always hold the chainsaw with your right hand on the rear handle and your left hand on the front handle.** Holding the chainsaw with a reversed hand configuration increases the risk of personal injury and should never be done.
- **Hold the power tool by insulated gripping surfaces only, because the saw chain may**

# SAFETY INFORMATION

---

- contact hidden wiring.** Saw chains contacting a “live” wire may make exposed metal parts of the power tool “live” and could give the operator an electric shock.
- **Wear safety glasses and hearing protection. Further protective equipment for head, hands, legs and feet is recommended.** Adequate protective clothing will reduce personal injury by flying debris or accidental contact with the saw chain.
  - **Always keep proper footing and operate the chainsaw only when standing on fixed, secure and level surface.** Slippery or unstable surfaces such as ladders may cause a loss of balance or control of the chainsaw.
  - **When cutting a limb that is under tension be alert for spring back.** When the tension in the wood fibres is released the spring loaded limb may strike the operator and/or throw the chainsaw out of control.
  - **Use extreme caution when cutting brush and saplings.** The slender material may catch the saw chain and be whipped toward you or pull you off balance.
  - **Follow instructions for lubricating, chain tensioning and changing accessories.** Improperly tensioned or lubricated chain may either break or increase the chance for kickback.
  - **Only cut wood.** Do not use the chainsaw for any purpose other than for which it is intended. For example: do not use the chainsaw to cut plastic materials, masonry or constructions other than wood. Using the chainsaw for operations other than those for which it is intended can cause hazardous situations.
  - **Keep handles dry, clean, and free from oil and grease.** Greasy, oily handles are slippery causing loss of control.

## CHILD SAFETY

Tragic accidents can occur if the operator is not aware of the presence of children.

- Keep children out of the working area and under the watchful care of a responsible adult.
- Do not allow children under the age of 18 to operate this chainsaw. Children who are 18 years of age and older must read and understand the operating instructions and safety rules in this manual and must be trained and supervised by a parent.
- Stay alert, and turn the chainsaw off if a child or any other person enters the working area.
- Use extreme care when approaching blind corners, doorways, shrubs, trees, or other objects that may obscure your view of a child who may run into the path of the chainsaw.

# SAFETY INFORMATION

## ⚠ WARNING

Kickback may occur when the moving chain contacts an object at the upper portion of the tip of the guide bar or when the wood closes in and pinches the saw chain in the cut. Contact at the upper portion of the tip of the guide bar can cause the chain to dig into the object and stop the chain for an instant. The result is a lightning fast reverse reaction which kicks the guide bar up and back toward the operator. If the saw chain is pinched along the top of the guide bar, the guide bar can be driven rapidly back toward the operator. Either of these reactions can cause loss of saw control which can result in serious injury. Do not rely exclusively upon the safety devices built into the saw. As a chainsaw user, you should take several steps to keep your cutting jobs free from accident or injury.

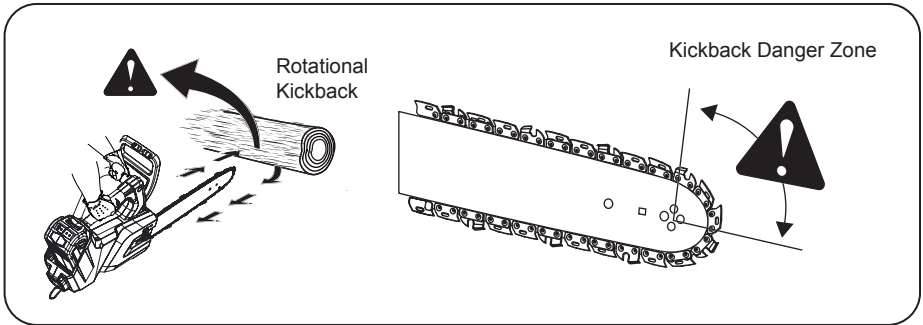





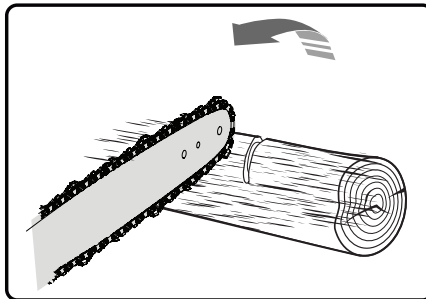







Kickbacks result from incorrect use of the tool and/or incorrect operating conditions or procedures, and can be avoided by taking the appropriate precautions specified below:

- **Maintain a firm grip, with thumbs and fingers encircling the chainsaw handles, with both hands on the saw and position your body and arm to allow you to resist kickback forces.** Kickback can be controlled by the operator, if proper precautions are taken. Do not let go of the chainsaw.
- **Do not overreach and do not cut above shoulder height.** This helps prevent unintended tip contact and enables better control of the chainsaw in unexpected situations.
- **Only use replacement bars and chains specified by the manufacturer.** Incorrect replacement bars and chains may cause chain breakage and/or kickback.
- **Follow the manufacturer's sharpening and maintenance instructions for the saw chain.** Decreasing the depth gauge height can lead to increased kickback.



# SYMBOLS



Some of the following symbols may be used on this product. Please study them and learn their meaning. Proper interpretation of these symbols will allow you to operate the product better and safer.

SYMBOLS	DESIGNATION	EXPLANATION
V	Volts	Voltage
A	Amperes	Current
Hz	Hertz	Frequency (cycles per second)
W	Watts	Power
hrs	Hours	Time
$n_0$	No Load Speed	Rotational speed, at no load
/ min	Per Minute	Revolutions, strokes, surface speed, orbits etc., per minute.
	Lithium-ion Battery Recycling	Designates that this tool is in compliance with lithium-ion battery recycling program requirements.
	Safety Alert Symbol	Precautions that involve your safety.
	Read the Instruction Manual	To reduce the risk of injury, user must read and understand the Instruction manual before using this product.
	Eye Protection	Wear eye protection when operating this equipment.
	Wear Ear Protection	Wear ear protection when operating this equipment.
	Gloves	Wear non-slip, heavy-duty protective gloves when handling the chainsaw and the blade.
	Safety Footwear	Wear non-slip safety footwear when using this equipment.
	Kickback	DANGER! Beware of kickback.
	Operate With Two Hands	Hold and operate the saw properly with both hands.
	Bar Nose Contact	Avoid bar nose contact.
	Wet Conditions Alert	Do not expose to rain or use in damp locations.
	One Handed	Do not operate the saw using only one hand.

# SYMBOLS

---

The following signal words and meanings are intended to explain the levels of risk associated with this product.

SYMBOL	SIGNAL	MEANING
	<b>DANGER</b>	Indicates an imminently hazardous situation, which, if not avoided, will result in death or serious injury.
	<b>WARNING</b>	Indicates a potentially hazardous situation, which, if not avoided, could result in death or serious injury.
	<b>CAUTION</b>	Indicates a potentially hazardous situation, which, if not avoided, may result in minor or moderate injury.
	<b>CAUTION</b>	(Without Safety Alert Symbol) Indicates a situation that may result in property damage.

## SERVICE

Servicing requires extreme care and knowledge and should be performed only by a qualified service technician. For service we suggest you return the product to your nearest **AUTHORIZED SERVICE CENTER** for repair. When servicing, use only identical replacement parts.

---

### **WARNING**

- Do not use on wet ground.
  - Disconnect before cleaning or changing accessories.
- 

### **WARNING**

To avoid serious personal injury, do not attempt to use this product until you have read this Owner's Manual thoroughly and understand it completely. If you do not understand the warnings and instructions in this Owner's Manual, do not use this product. Call the Toll-free Helpline (1-855-470-4267) for assistance.

---

### **WARNING**



The operation of any power tool can result in foreign objects being thrown into your eyes, which can result in severe eye damage. Before operating a power tool, always wear safety goggles, safety glasses with side shields, or a full face shield when needed. We recommend a Wide Vision Safety Mask for use over eyeglasses or standard safety glasses with side shields. Always use eye protection that is marked to comply with ANSI Z87.1.

---

**SAVE THESE INSTRUCTIONS**

---



# KNOW YOUR CHAINSAW

## KNOW YOUR CHAINSAW

The safe use of this product requires an understanding of the information on the product and in this operator's manual as well as a knowledge of the project you are attempting. Before use of this product, familiarize yourself with all operating features and safety rules.

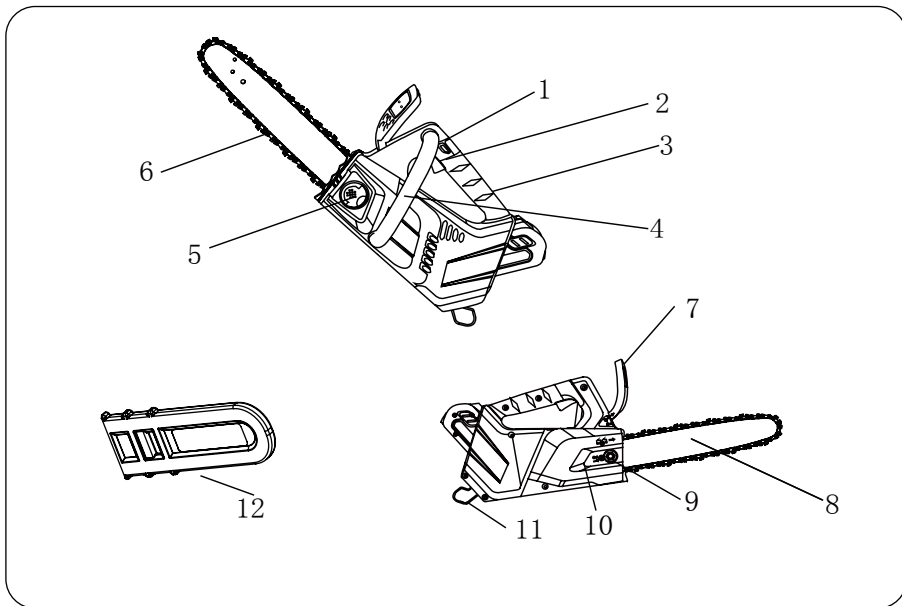

1. Safety Lock	7. Chain Brake
2. Trigger	8. Guide Bar
3. Top Handle	9. Chain Guard Retainment Nut
4. Assistant Handle	10. Chain Cover
5. Oil Cap	11. Hook
6. Chain	12. Scabbard

# ASSEMBLY

---

## UNPACKING

This product has been shipped completely assembled.

- Carefully remove the product and any accessories from the box. Make sure that all items listed in the package list section are included.
- Inspect the product carefully to make sure no breakage or damage occurred during shipping.
- Do not discard the packing material until you have carefully inspected and satisfactorily operated the product.
- If any parts are damaged or missing, please call 1-855-470-4267 for assistance.

## PACKING LIST

- Chainsaw (Bar and Chain)
- Scabbard
- Operator's Manual

---

## **▲ W A R N I N G**

If any parts are damaged or missing, do not operate this product until the parts are replaced. Using a product with damaged or missing parts could result in serious personal injury.

---

## **▲ W A R N I N G**

Do not attempt to modify this product or create accessories not recommended for use with this product. Any such alteration or modification is misuse and could result in a hazardous condition leading to possible serious personal injury.

---

## **▲ W A R N I N G**

Do not insert the battery until assembly is complete. Failure to comply could result in accidental starting and possible serious personal injury.

---

# ASSEMBLY

---

## ADDING BAR AND CHAIN LUBRICANT (See Figure 2)

Use a bar and chain lubricant with this product. It is designed for chains and chain oilers, and is formulated to perform over a wide temperature range with no dilution required.

- Remove oil cap. Open the removable cover and then rotate the cover counterclockwise to remove it.
- Carefully pour the bar and chain oil into the tank.
- Wipe off excess oil and replace cap.
- Check and fill the oil tank.
- Repeat as needed.

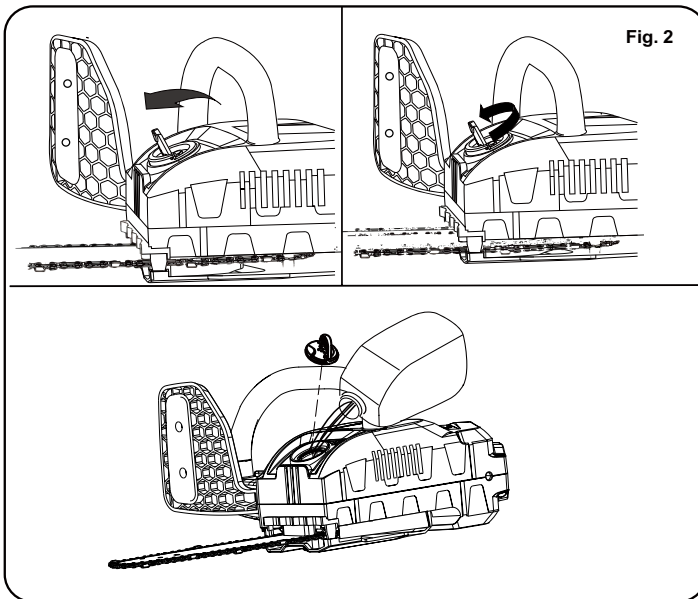

**NOTE:** Chainsaw comes from the factory with no bar and chain oil added. The level should also be checked after every 20 minutes of use and refilled as needed.

### NOTE:

- Do not use dirty, used, or otherwise contaminated oils. Damage may occur to the bar or chain.
- It is normal for oil to seep from the saw when not in use. To prevent seepage, empty the oil tank after each use, then run for one minute. When storing the unit for a long period of time (three months or longer) be sure the chain is lightly lubricated; this will prevent rust on the chain and bar sprocket.

# ASSEMBLY

---

## **▲ I M P O R T A N T**

To preserve natural resources, please recycle or dispose of oil properly. Consult your local waste authority for information regarding available recycling and/disposal options.

---

### **BATTERY**

#### **TO INSTALL THE BATTERY:**

1. Align the battery with the battery opening.
2. Insert the battery into the battery opening until the battery release button locks into place. You should hear a “click” once it is installed

#### **TO REMOVE THE BATTERY:**

1. Press the battery release button on the battery.
2. Grasp the chainsaw firmly and pull the battery out of the handle.

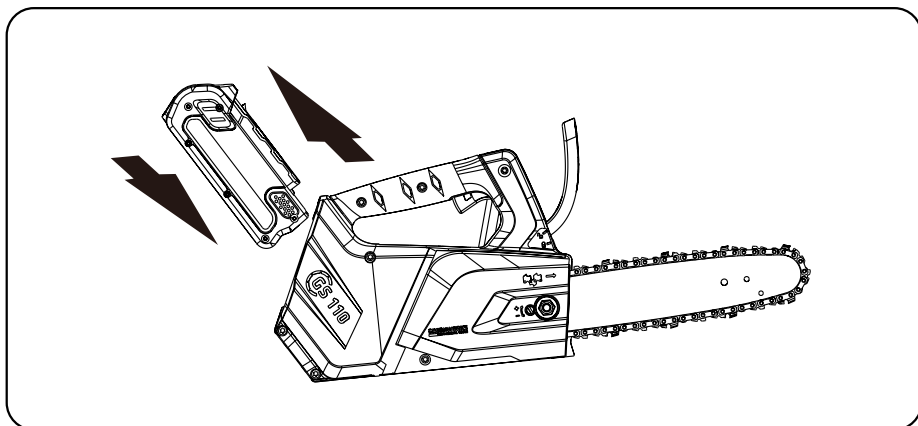

## **▲ W A R N I N G**

The battery may not be charged when it is purchased. Before using the chainsaw for the first time, place the battery in the battery charger and charge it fully. Be sure to read all safety precautions and follow the instructions in the battery and charger manuals. When storing the chainsaw for a prolonged period of time, remove the battery. When the chainsaw is going to be used again, charge the battery for at least a full charging period. The battery has no memory effect.

---

## **▲ W A R N I N G**

Follow these instructions in order to avoid injury and to reduce the risk of electric shock or fire:

- Replace the battery or the charger immediately if the battery case or charger accord is damaged.
  - Read, understand, and follow the instructions contained in the charger manual.
-

# OPERATION

---

## STARTING AND STOPPING THE CHAINSAW

### A. Starting the chainsaw:

- Make sure chain tension is at desired setting. Refer to adjusting the chain tension in the Care and Maintenance section of this manual.
- Make sure no objects or obstructions are in the immediate vicinity which could come in contact with the bar and chain.
- Insert the battery into the chainsaw.
- Press in the safety lock. This makes the trigger operational.
- Press and hold the trigger, and keep it pressed for continued operation.

### B. Stopping the chainsaw

- Release the trigger.
- Upon release of the trigger, the safety lock will be automatically reset to the lock position.
- This chainsaw is equipped with a mechanical chain brake which is designed to stop a moving chain in a fraction of a second if kickback occurs, reducing the chances of severe injury. To manually engage the chain brake push the chain brake forward. This action will lock the chain from moving; to release the chain brake, pull the brake toward the handle. This will reset the chain brake.

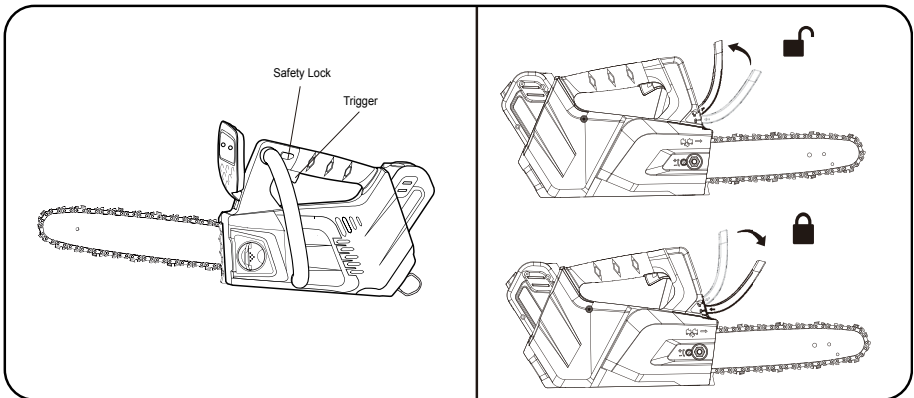

**NOTE:** It is normal for the chain to coast to a stop once the trigger is released.

# OPERATION

## BASIC OPERATING/CUTTING PROCEDURES

Practice cutting a few small logs using the following technique to get the “feel” of using the saw before you begin a major sawing operation.

- Take the proper stance in front of the wood.
- Press the safety lock in and squeeze the trigger, then release the safety lock and let the chain accelerate to full speed before entering the cut.
- Begin cutting with the saw against the log.
- Keep the unit running the entire time you are cutting, maintain a steady speed.
- The chain will cut for you; **exert only light downward pressure**. Forcing the cut could result in damage to the bar, chain, or motor.
- Release the trigger as soon as the cut is completed, allowing the chain to stop. If you run the saw without a cutting load, unnecessary wear can occur to the chain, bar, and unit.
- Do not put pressure on the saw at the end of the cut.

## REMOVING BUTTRESS ROOTS

A buttress root is a large root extending from the trunk of the tree above the ground. Remove large buttress roots prior to felling. Make the horizontal cut into the buttress first, followed by the vertical cut. Remove the resulting loose section from the work area. Follow the correct tree felling procedure as stated in Proper Procedure For Tree Felling after you have removed the large buttress roots.

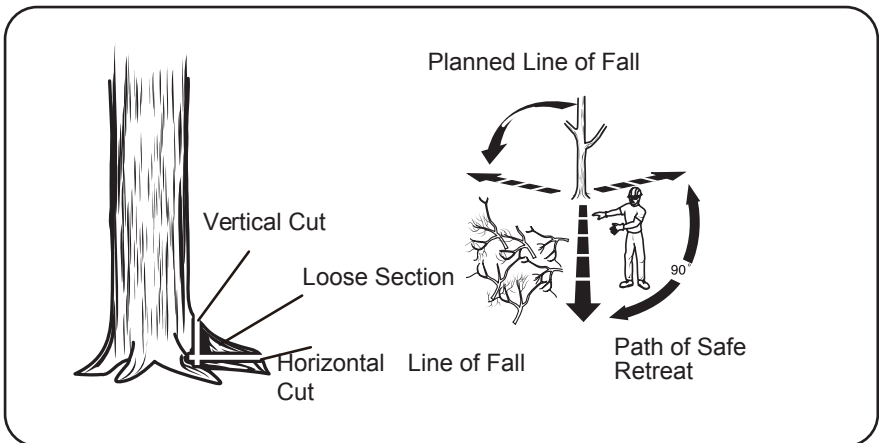

## PROPER PROCEDURE FOR TREE FELLING

- Felling a tree — When bucking and felling operations are being performed by two or more persons at the same time, the felling operation should be separated from the bucking operation by a distance of at least twice the height of the tree being felled. Trees should not be felled in a manner that would endanger any person, strike any utility line or cause any property damage. If the tree does make contact with any utility line, the utility company should be notified immediately.
- Operator should keep on the uphill side of terrain as the tree is likely to roll or slide after it is felled.
- Pick your escape route (or routes in case the intended route is blocked). Clear the

# OPERATION

immediate area around the tree and make sure there are no obstructions in your planned path of retreat. Clear the path of safe retreat approximately  $135^\circ$  from the planned line of fall.

- Consider the force and direction of the wind, the lean and balance of the tree, and the location of large limbs. These things influence the direction in which the tree will fall. Do not try to fell a tree along a line different from its natural line of fall.
- Remove dirt, stones, loose bark, nails, staples, and wire from the tree where felling cuts are to be made.
- Notched Undercut. Cut a notch about  $1/3$  the diameter of the trunk on the side of the tree. Make the notch cuts so they intersect at a right angle to the line of fall. This notch should be cleaned out to leave a straight line. To keep the weight of the wood off the saw, always make the lower cut of the notch before the upper cut.
- Felling Backcut. As the felling cut gets close to the hinge, the tree should begin to fall. If there is any chance the tree may not fall in the desired direction or it may rock back and bind the saw chain, stop cutting before the felling cut is complete and use wedges of wood, plastic or aluminum to open the cut and drop the tree along its desired line of fall. Make the backcut level and horizontal, and at a minimum of 2 in. (5 cm) above the horizontal cut of the notch.
- On large diameter trees, stop the back cut before it is deep enough for the tree to either fall or settle back on the stump. Then insert soft wooden or plastic wedges into the cut so they do.
- As tree starts to fall, stop the chainsaw and put it down immediately. Retreat along the cleared path, but watch the action in case something falls your way.

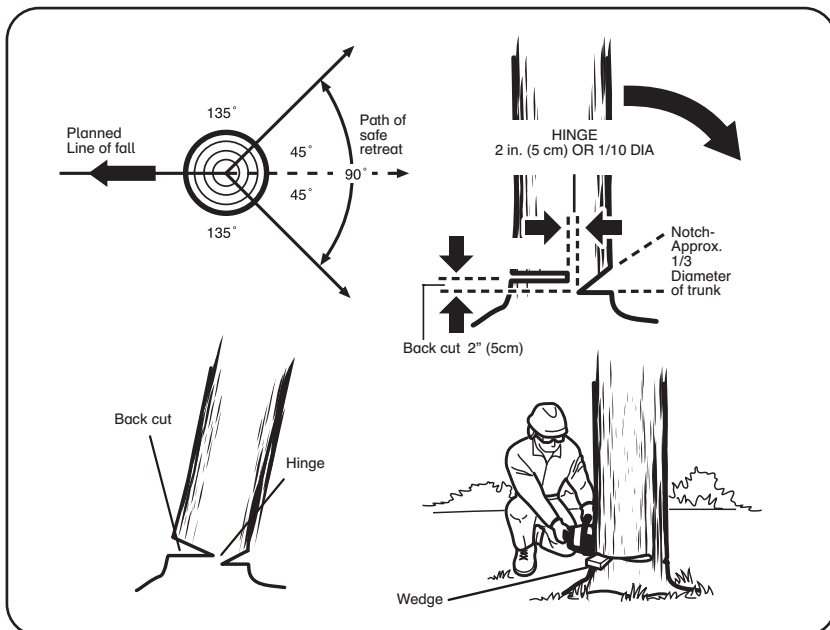

# OPERATION

---

## BUCKING

Bucking is the term used for cutting a fallen tree to the desired log length.

- Always make sure your footing is secure and your weight is distributed evenly on both feet.
- Cut only one log at a time.
- Support small logs on a saw horse or another log while bucking.
- Keep a clear cutting area. Make sure that no objects can contact the guide bar nose and chain during cutting as this can cause kickback. Refer to Kickback earlier in this manual.
- When bucking on a slope, always stand on the uphill side of the log. To maintain complete control of the chainsaw when cutting through the log, release the cutting pressure near the end of the cut without relaxing your grip on the chainsaw handles. Do not let the chain contact the ground. After completing the cut, wait for the saw chain to stop before you move the chainsaw. Always stop the motor before moving from tree to tree.

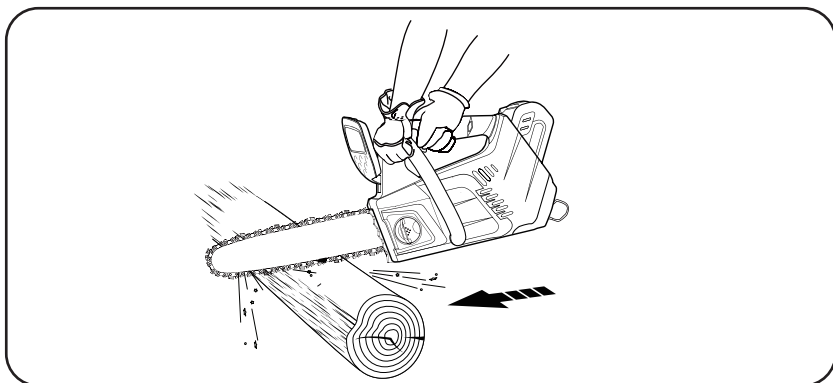

## BUCKING WITH A WEDGE

If the wood diameter is large enough for you to insert a soft bucking wedge without touching the chain, you should use the wedge to hold the cut open to prevent pinching.

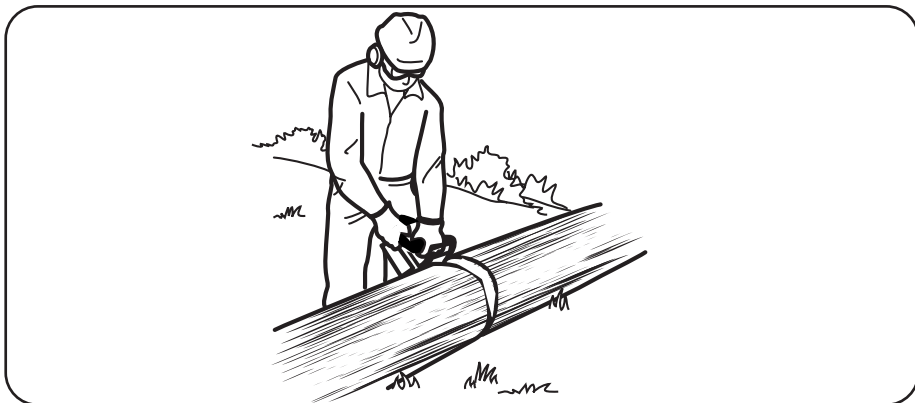



# OPERATION

## BUCKING LOGS UNDER STRESS

When the log is supported on one end, cut 1/3 the diameter from the underside. Then make the finished cut by overbucking to meet the first cut. When the log is supported on both ends, cut 1/3 of the diameter from the top overback. Then make the finished cut by under bucking the lower 2/3 to meet the first cut.

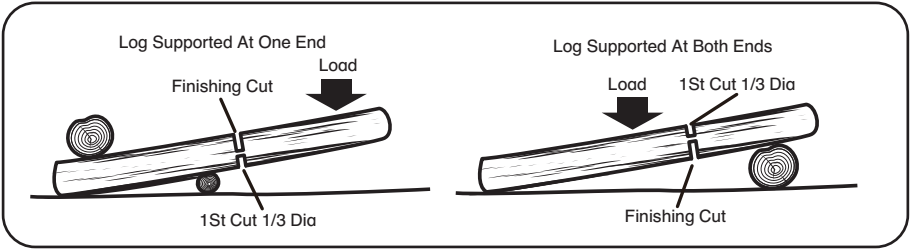

## OVERBUCKING

Begin on the top side of the log with the bottom of the saw against the log; exert light pressure downward. Note that the saw will tend to pull away from you.

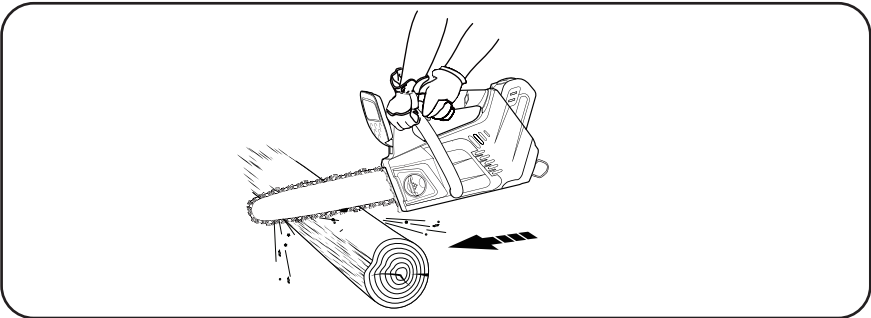

## UNDERBUCKING

Begin on the under side of the log with the top of the saw against the log; exert light pressure upward. During under bucking, the saw will tend to push back at you. Be prepared for this reaction and hold the saw firmly to maintain control.

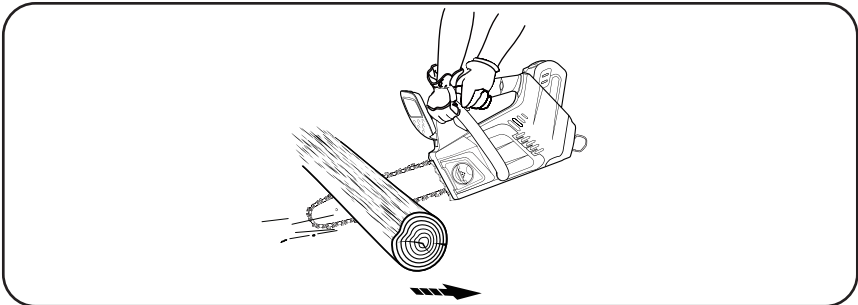

# OPERATION

## LIMBING

Limbing is removing branches from a fallen tree.

- Work slowly, keeping both hands on the chainsaw with a firm grip. Always make sure your footing is secure and your weight is distributed evenly on both feet.
- Leave the larger support limbs under the tree to keep the tree off the ground while cutting.
- Limbs should be cut one at a time. Remove the cut limbs from the work area often to help. Keep the work area clean and safe.
- Branches under tension should be cut from the bottom up to avoid binding the chainsaw.
- Keep the tree between you and the chainsaw while limbing. Cut from the side of the tree opposite the branch you are cutting.

## PRUNING

Pruning is trimming limbs from a live tree.

- Work slowly, keeping both hands on the chainsaw with a firm grip. Always make sure your footing is secure and your weight is distributed evenly on both feet.
- Do not cut from a ladder. This is extremely dangerous. Leave this operation for professionals.
- Do not cut above chest height as a saw held higher is difficult to control against kickback.
- When pruning trees it is important not to make the finishing cut next to the main limb or trunk until you have cut off the limb further out to reduce the weight. This prevents stripping the bark from the main member.
- Underbuck the branch 1/3 through for your first cut.
- Your second cut should overbuck to drop the branch off.
- Now make your finishing cut smoothly and neatly against the main member so the bark will grow back to seal the wound.

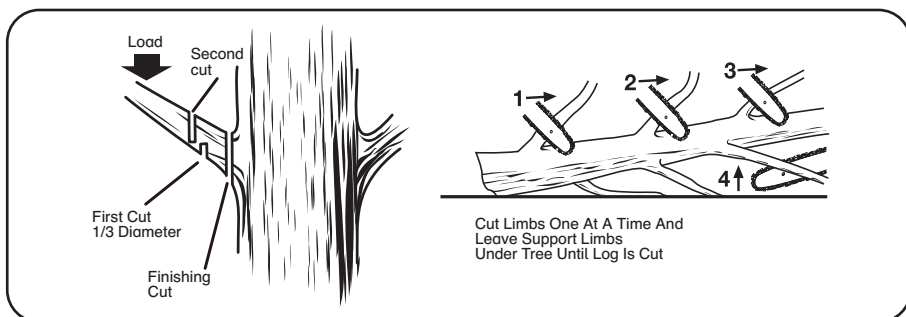

# OPERATION

---

When bucking on a slope always stand on the uphill side of the log. When cutting through to maintain complete control release the cutting pressure near the end of the cut without relaxing your grip on the chainsaw handle. Do not let the chain contact the ground. After completing the cut, wait for the saw chain to stop before you move the chainsaw. Always stop the motor before moving from tree to tree.

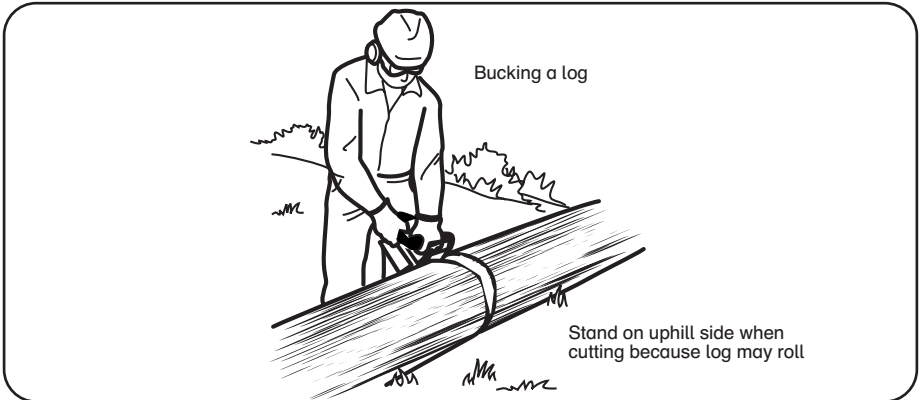

## CUTTING SPRINGPOLES

A springpole is any log, branch, rooted stump, or sapling which is bent under tension by other wood so that it springs back if the wood holding it is cut or removed. On a fallen tree, a rooted stump has a high potential of springing back to the upright position during the bucking cut to separate the log from the stump. Watch out for springpoles — they are dangerous.

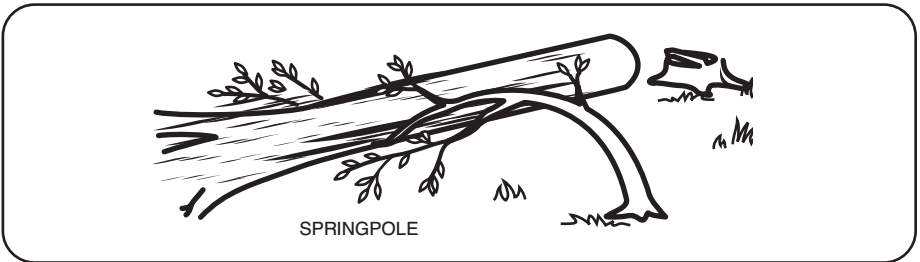

---

## **▲ WARNING**

If the limbs to be pruned are above chest height, hire a professional to perform the pruning.

---

## **▲ WARNING**

Springpoles are dangerous and could strike the operator, causing the operator to lose control of the chain saw. This could result in severe or fatal injury to the operator.

# MAINTENANCE

---

## GENERAL MAINTENANCE

Avoid using solvents when cleaning plastic parts. Most plastics are susceptible to damage from various types of commercial solvents and may be damaged by their use. Use clean cloths to remove dirt, dust, lubricant, grease, etc., firmly to maintain control.

- Do not at any time let brake fluids, gasoline, petroleum-based products, penetrating oils, etc., come in contact with plastic parts. Chemicals can damage, weaken, or destroy plastic, which may result in serious personal injury.

## LUBRICATION

- All of the bearings in this product are lubricated with a sufficient amount of high grade lubricant for the life of the unit under normal operating conditions. Therefore, no further lubrication is required.

---

## **⚠ WARNING**

- When servicing, use only identical replacement parts. Use of any other parts may create a hazard or cause product damage.
- Always wear safety goggles or safety glasses with side shields during power tool operation or when blowing dust. If the operation is dusty, also wear a dust mask.

---

## **⚠ WARNING**

- Never start the motor before installing the guide bar, chain, bar cover, and bar nuts. Without all these parts in place, the clutch can fly off or explode, exposing the user to possible serious injury.

---

## **⚠ WARNING**

- To avoid serious personal injury, read and understand all the safety instructions in this section.
- Before performing any maintenance, make sure the battery is removed. Failure to heed this warning could result in serious personal injury.

---

## **⚠ WARNING**

- Always wear gloves when handling the bar and chain; these components are sharp and may contain burrs.
- Never touch or adjust the chain while the motor is running. The saw chain is very sharp; always wear protective gloves when performing maintenance to the chain to avoid possible serious lacerations.

---

**NOTE:** When replacing the guide bar and chain, always use the specified bar and chain listed in the bar and chain combinations section later in this manual.

# MAINTENANCE

---

## ADJUSTING THE CHAIN TENSION

### **⚠ WARNING**

Never touch or adjust the chain while the motor is running. The saw chain is very sharp. Always wear protective gloves when performing maintenance on the chain.

- Loosen the chain cover lock nuts with the supplied wrench.
- Rotate the chain adjustment screw clockwise to increase the chain tension and rotate counterclockwise to decrease the chain tension.
- Once the chain is at the desired tension, tighten the chain cover lock nuts.

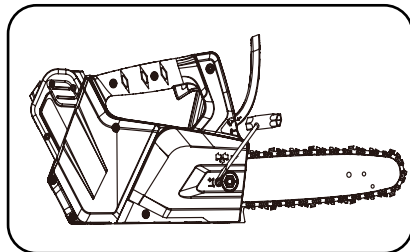
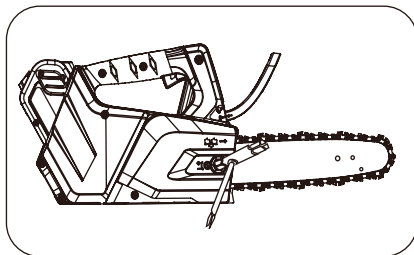

*NOTE: During normal saw operation, the temperature of the chain increases. The drive links of a correctly tensioned warm chain will hang approximately 1/16 in. (1,58 mm) out of the bar groove.*

*NOTE: New chains tend to stretch; check the chain tension frequently and tension as required.*

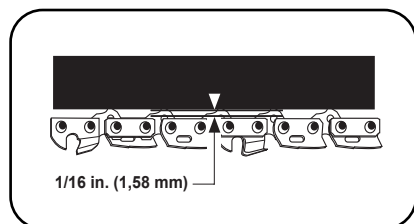

# MAINTENANCE

## REPLACING THE BAR AND CHAIN

- Remove the chain cover.
- The bar contains a bar stud slot that fits over the bar stud. The bar also contains a chain tensioning pin hole that fits over the chain tensioning pin.
- Place the bar onto the bar stud so that the chain tensioning pin fits into the chain tensioning pin hole. Fit the chain over the sprocket and into the bar groove. The cutters on the top of the bar should face toward the bar tip, in the direction of the chain rotation.
- Replace the chain cover.
- Remove all slack from chain by turning the chain tensioning bolt clockwise, assuring that the chain seats into the bar groove during tensioning.
- Lift the tip of the bar up to check for sag. Release the tip of the bar, and turn the chain tensioning bolt 1/2 turn clockwise.
- Repeat this process until the sag no longer exists.
- Hold the tip of the bar up and tighten the locked bolt securely.
- The chain is correctly tensioned when there is no slack on the underside of the bar, the chain is snug, and it can be turned by hand without binding.

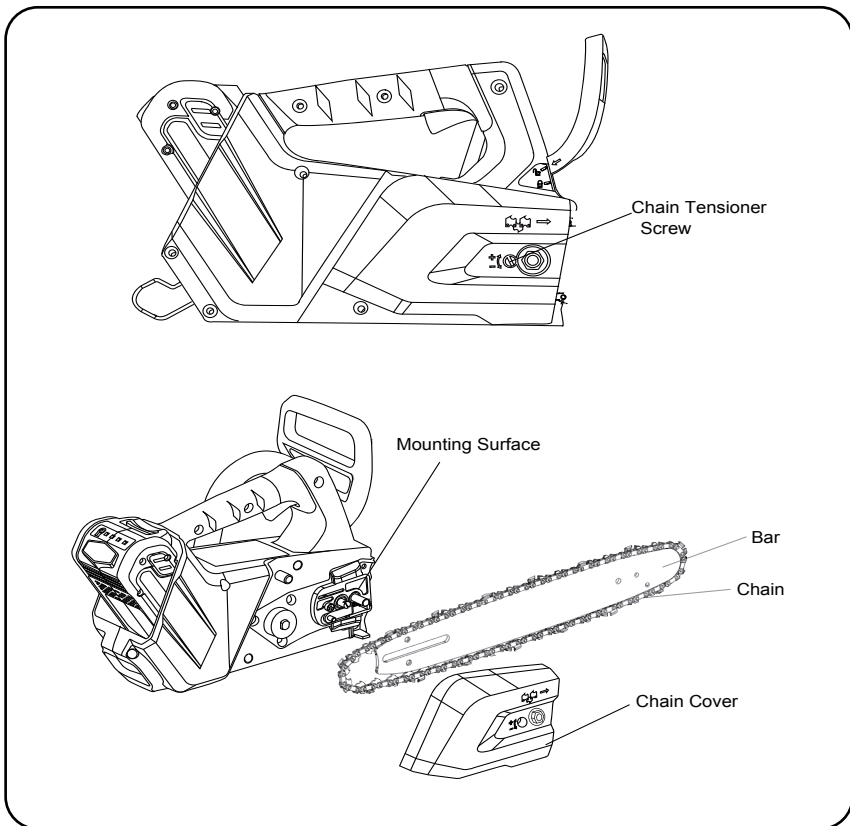

# MAINTENANCE

---

## CHAIN OILER

- Use a lubricant that is designed for chains and chain oilers and is formulated to perform over a wide temperature range with no dilution required.
- Remove the cap and carefully pour bar and chain lubricant into the bar lube reservoir.
- Replace the cap and tighten securely.
- Check and refill the bar lube reservoir every time the chainsaw is used.

## CHAIN MAINTENANCE

Use only a low-kickback chain on this saw. This fast-cutting chain provides kickback reduction when properly maintained. For smooth and fast cutting, maintain the chain properly. The chain requires sharpening when the wood chips are small and powdery, the chain must be forced through the wood during cutting, or the chain cuts to one side. During maintenance of the chain, consider the following:

- Improper filing angle of the side plate can increase the risk of severe kickback.
- Raker (depth gauge) clearance.
- Too low increases the potential for kickback.
- Not low enough decreases cutting ability.
- If the cutter teeth hit hard objects such as nails or stones, or are abraded by mud or sand on the wood, have an authorized service center sharpen the chain.

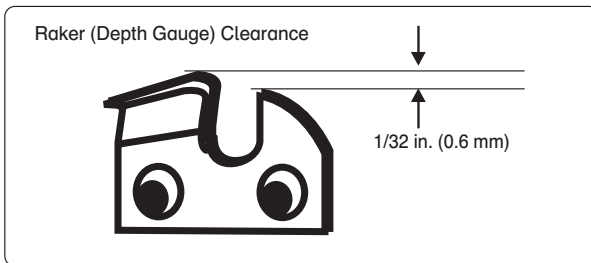

### NOTE:

- Inspect the sprocket for wear or damage when replacing the chain. If signs of wear or damage are present in the areas indicated, have the sprocket replaced by an authorized service center.
- If you do not fully understand the correct procedure for sharpening the chain after reading the instructions that follow, have the saw chain sharpened by an authorized service center or replace with a recommended low-kickback chain.

# MAINTENANCE

## SHARPENING THE CUTTERS

- Be careful to file all cutters to the specified angles and to the same length, as fast cutting can be obtained only when all cutters are uniform.
- Tension the chain prior to sharpening. Refer to Page 21.
- Use a round file and holder. Do all of your filing at the midpoint of the bar.
- Keep the file level with a top plate of the tooth. Do not let the file dip or rock.
- Using light but firm pressure. Stroke towards the front corner of the tooth.
- Lift the file away from the steel on each return stroke.
- Put a few firm strokes on every tooth. File all left hand cutters in one direction. Then move to the other side and file the right hand cutters in the opposite direction.
- Remove filings from the file with a wire brush.

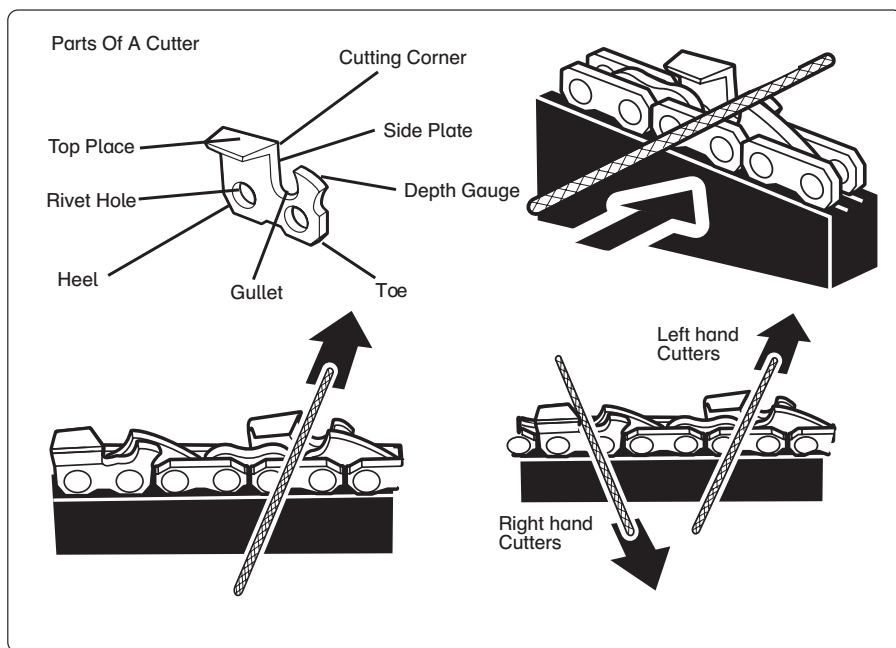

## ⚠ WARNING

- Make sure the battery is removed from the chainsaw before you work on the saw.
- The saw chain is very sharp. Always wear protective gloves when performing maintenance to the chain to prevent serious personal injury.
- A dull or improperly sharpened chain can cause excessive motor speed during cutting, which may result in severe motor damage.



# MAINTENANCE

## TOP PLATE FILING ANGLE

- CORRECT 30° – file holders are marked with guide marks to align file properly to produce correct top plate angle.
- LESS THAN 30° – for cross cutting.
- MORE THAN 30° – feathered edge dulls quickly.

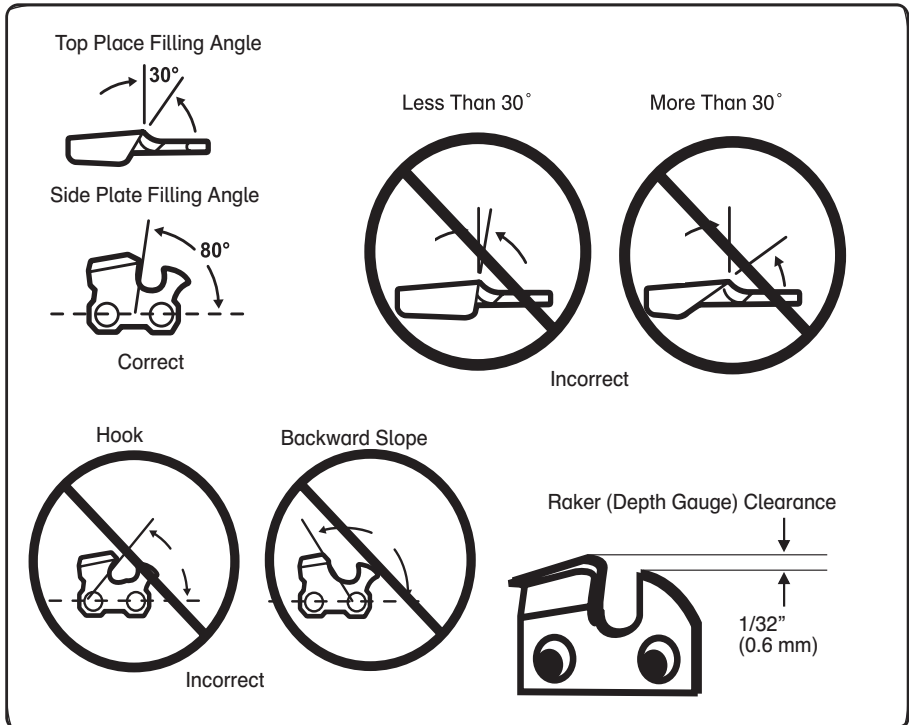

## SIDE PLATE ANGLE

- Correct 80° – Produced automatically if you use the correct diameter file in the file holder.
- Hook – “Grabs” and dulls quickly; increases the potential of kickback. Results from using a file with a diameter too small or a file held too low.
- Backward Slope – Needs too much feed pressure; causes excessive wear to the bar and chain. Results from using a file with a diameter too large or file held too high.

# MAINTENANCE

---

## SIDE PLATE ANGLE

- Maintain the depth gauge at a clearance of 1/32 in. (0.6 mm). Use a depth gauge tool for checking the depth gauge clearances.
- Every time the chain is filed, check the depth gauge clearance.
- Use a flat file and a depth gauge jointer to lower all gauges uniformly. Use a 1/32 in (0.6 mm) depth gauge jointer. After lowering each depth gauge, restore original shape by rounding the front.
- Depth gauges must be adjusted with the flat file in the same direction the adjoining cutter was filed with the round file.
- Use care not to contact cutter face with flat file when adjusting depth gauges.

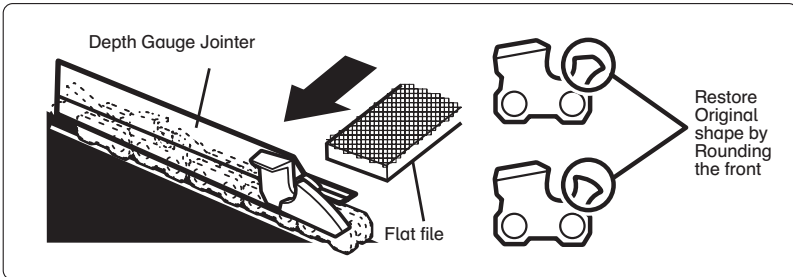

## MAINTAINING THE GUIDE BAR

Every week of use, reverse the guide bar on the saw to distribute the wear for maximum bar life. The bar should be cleaned every day of use and checked for wear and damage. Feathering or burring of the bar rails is a normal process of bar wear. Such faults should be smoothed with a file as soon as they occur. A bar with any of the following faults should be replaced:

- Wear inside the bar rails that permits the chain to lay over sideways
- Bent guide bar
- Cracked or broken rails
- Spread rails

Lubricate guide bars weekly with a sprocket at their tip. Using a grease syringe, lubricate weekly in the lubricating hole. Turn the guide bar and check that the lubrication holes and chain groove are free from impurities.

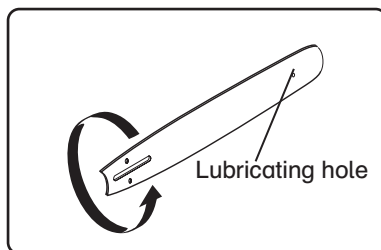

# ENVIRONMENTALLY SAFE BATTERY DISPOSAL

---

The batteries used in this chainsaw's battery pack contain the following toxic and corrosive material: LITHIUM-ION.



---

## **▲ W A R N I N G**

Toxic materials must be disposed of in a specific manner in order to prevent contamination of the environment. Before disposing of damaged or worn out Lithium-Ion battery packs, contact your local waste disposal agency or the local Environmental Protection Agency for information and specific instructions. Take the batteries to a local recycling and/or disposal center that is certified for disposal. If the battery pack cracks or breaks, whether it leaks or not, do not recharge it and do not use it. Dispose of it and replace it with a new battery pack.

**DO NOT ATTEMPT TO REPAIR IT!**

---

Follow these instructions and to avoid damage to the environment:

- Cover the battery's terminals with heavy-duty adhesive tape.
- Do not attempt to remove or destroy any of the components of the battery pack.
- Do not attempt to open the battery pack.
- If a leak develops, the electrolytes that are released are corrosive and toxic. Do not get the solution in the eyes or on the skin, and do not swallow it.
- Do not place batteries in regular household trash.
- DO NOT incinerate batteries.
- DO NOT place batteries where they will become part of any waste landfill or municipal solid waste stream.
- Dispose of batteries at a certified recycling or disposal center.

# TROUBLESHOOTING

<b>PROBLEM</b>	<b>POSSIBLE CAUSE</b>	<b>SOLUTION</b>
Bar and saw chain running hot and smoking.	Check saw chain tension for overtightened condition.	Tension saw chain.
	No oil in the oil tank.	Refill oil into the oil tank.
	The discharge port is blocked by debris.	Refer to the manual to remove the bar and clean out the debris.
	Oil tank is blocked by debris.	Clean out the oil tank and refill with clean oil.
	Bar and chain oil tank cap is blocked by debris.	Clean the debris off the oil cover.
Motor runs, but chain is not rotating.	The sprocket or guide wheel is clogged with debris.	Clean and remove debris from sprocket and guide wheel.
	Saw chain tension is too tight.	Refer to Saw Chain Tension Guide earlier in this manual.
	Check guide bar and saw chain assembly.	Refer to Page 21.
Motor runs, chain rotates but does not cut.	Check guide bar and saw chain for damage.	Remove the battery from the unit. Take the bar cover off, and remove the bar and saw chain. Clean all debris from the chainsaw. After all debris is cleared, insert battery and run the chainsaw. If the sprocket is spinning your motor is okay. If the sprocket is not spinning, call customer service.
	Dull chain.	Sharpen or replace the saw chain.
Chainsaw does not start.	Chain on backwards.	Refer to Replacing the Bar and Saw Chain assembly earlier in this manual.
	Chain tension could be overtightened or too loose.	Refer to Re-tensioning the saw chain in the manual.
	The chain brake is engaged.	Pull the chain brake towards you until the chain brake is disengaged.
Chainsaw does not start.	No electrical contact between the chainsaw and battery.	To secure the battery, make sure the latches on the battery compartment snap into place.
	The battery pack is depleted.	Charge the battery pack.
	The battery and power tool is too hot or too cold.	Refer to the battery and charger maintenance part in the manual.

# TROUBLESHOOTING

---

PROBLEM	POSSIBLE CAUSE	SOLUTION
Motor running, but cutting abnormal.	Motor stops after about 10 seconds.	Recharge the battery.
	If the unit cuts off and beeps during a cut, it went into protection mode. This protects the PCB from damage.	Release the trigger and restart the chainsaw. Let the chainsaw do the work and do not force the cut.
	Battery is not charged.	Charge the battery. Refer to the battery and charger manual for correct charging procedures.
	The saw chain needs lubrication, and will increase friction if not properly maintained.	Make sure the chain is always lubricated by never letting the bar and chain oil run low.
	Incorrect battery storage temperature.	Allow the battery pack to cool until it drops to room temperature.

---

## **⚠ W A R N I N G**

Disconnect the battery pack from the appliance before making any adjustments, changing accessories, or storing appliance. Such preventive safety measures reduce the risk of starting the appliance accidentally.

---

# LIMITED WARRANTY

---



GREENWORKS™ hereby warranties this product, to the original purchaser with **proof of purchase**, 2 year commercial power train warranty, 2 year commercial battery warranty against defects in materials, parts or workmanship. GREENWORKS™, at its own discretion will repair or replace any and all parts found to be defective, through normal use, free of charge to the customer. This warranty is valid only for units which have been used for personal use that have not been hired or rented and that have been maintained in accordance with the instructions in the owners' manual supplied with the product from new.

## **2 Year Limited Power Train Warranty Coverage:**

- Motor
- PCB Boards
- Gear Box
- 2 years from the date of purchase (non transferable)

## **2 Year Limited Battery Warranty Coverage:**

- Greenworks Commercial Battery Packs (GL 200, GL 250, GL 300, GL 400, GL 500, GL 900)
- 2 year from the date of purchase (non transferable)

## **60 Day Limited Wearable Parts Warranty Coverage:**

- Bars
- Blades
- Guards
- Chains
- Bump Feed Heads
- Tines
- 60 Days from date of purchase (non transferable)

## **Warranty Exclusions, Limitations and Rights:**

1. All warranties may not be transferred by the consumer to any subsequent purchaser.
2. Parts or components not supplied by the warrantor, or parts or components that have been modified.
3. Any failure resulting from the use of improper tools or improper repair procedures.
4. Any failure or part that has become inoperative due to accident, impact, abuse, misuse, neglect, mishandling, dulling of cutting edges, or failure to operate the product in accordance with the information provided in the instruction manual

# LIMITED WARRANTY

---

supplied with the product.

5. Normal deterioration of the exterior due to use or exposure, and any repairs made necessary by normal wear, improper maintenance, improper lubrication, improper storage, dirt, abrasives, impact, moisture, water, rain, snow, rust, corrosion, varnish, or other similar conditions.
6. Routine maintenance items such as lubricants, blade sharpening.
7. The unit, if it has not been operated and/or maintained in accordance with the owner's manual.
8. Improper voltage for electric products and batteries that have been exposed to temperatures beyond those specified in the product's instruction manual, batteries that have not been properly charged or batteries that have reached their useful life.

## **GREENWORKS HELPLINE:**

Warranty service is available by calling our toll-free helpline, at **1-855-470-4267**.

## **TRANSPORTATION CHARGES:**

Transportation charges for the movement of any power equipment unit or attachment are the responsibility of the purchaser. It is the purchaser's responsibility to pay transportation charges for any part submitted for replacement under this warranty unless such return is requested in writing by **GREENWORKS**.

# EXPLODED VIEW

---

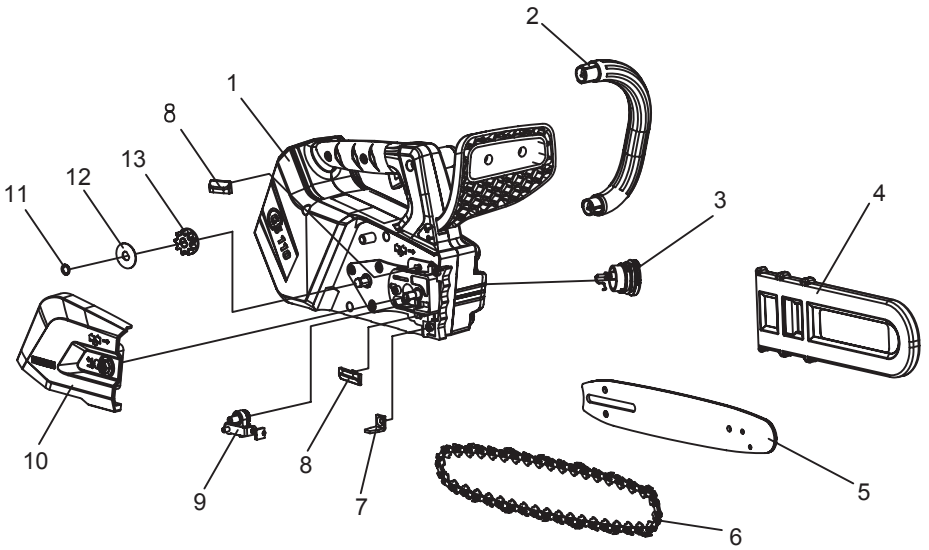



# PARTS LIST

---

ITEM NO.	PART NO.	DESCRIPTION	QTY
1	311061898	Chainsaw	1
2	341031898	Auxiliary Handle	1
3	311051898	Oil Cap Assembly	1
4	34114155C	Scabbard	1
5	322001726B	Bar	1
6	311101726	Chain	1
7	333061075	Chain Block Device	1
8	341101898	Block Chip	2
9	311031063A	Chain Tension Assembly	1
10	341051898	Side Cover	1
11	32209590A	C-Clip	1
12	33304590	Chain Wheel Washer	1
13	339001726A	Sprocket	1

# GREENWORKS

---

## COMMERCIAL

Greenworks Tools  
PO Box 1238  
Mooresville, NC 28115

**TOLL-FREE HELPLINE: 1-855-470-4267**

