

Cased-Hole and Slickline Unit

- » **Efficient cased-hole and slickline unit**
- » **Small footprint**
- » **Easy and quick rig up**

Cased-Hole, Slickline-3-Piece 2-Man Unit
 DNV 2.7-1 Certified Lift
 Class 1 Division 2

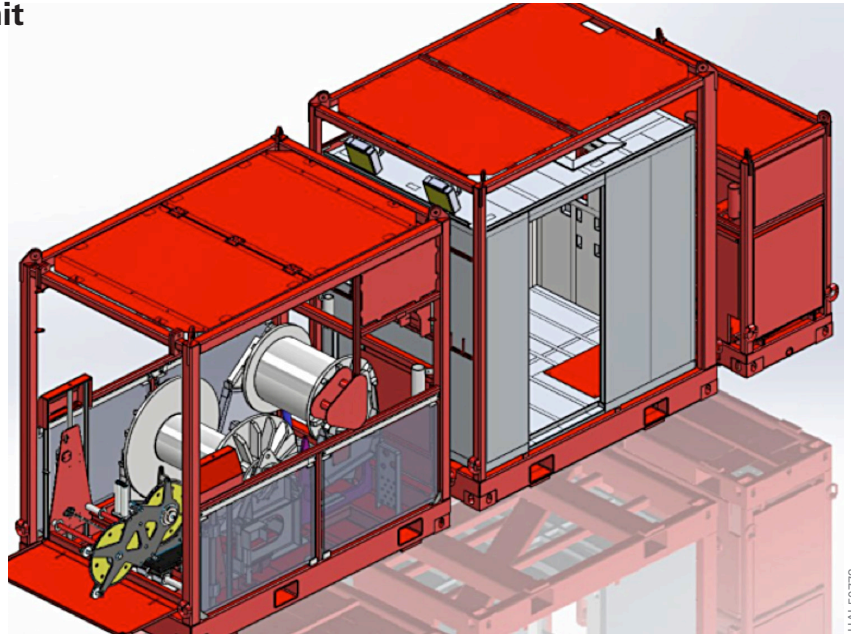

CABIN AND SKID FRAME ASSEMBLY

This unit is equipped to provide cased-hole and slickline services. It has two rooftop A/C units and 220-AC voltage.

DNV 2.7-1 Certified Lift
 Class 1 Division 2
 Overall Size: 103 in. L x 72.625 in. W x 117.5 in. T
 Max Gross: 8,000 lb

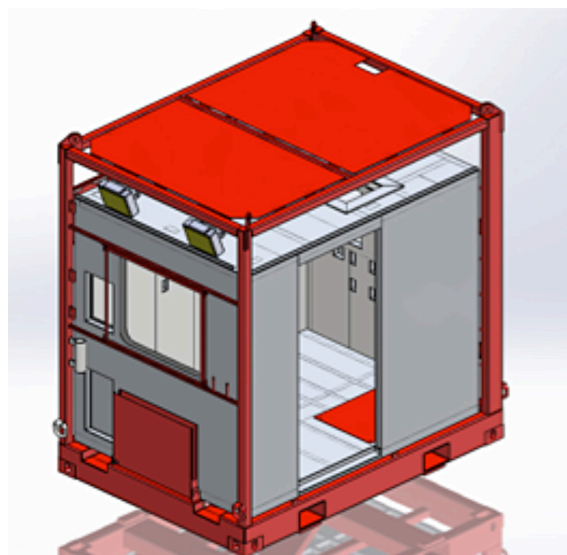

DUAL REEL SKID PACKAGE

Equipped with Cummins QSB 4.5 Dual Reel Skid Package Direct Drive is equipped with 4-lb Slickline, Cased-Hole 14-lb Reel, and Benchmark Mako Head. It is Certified Electrical Connection only.

DNV 2.7-1 Certified Lift
Class 1 Division 2
Overall Size: 110 in. L x 72 in. W x 110.75 in. T
Max Gross: 18,000 lb

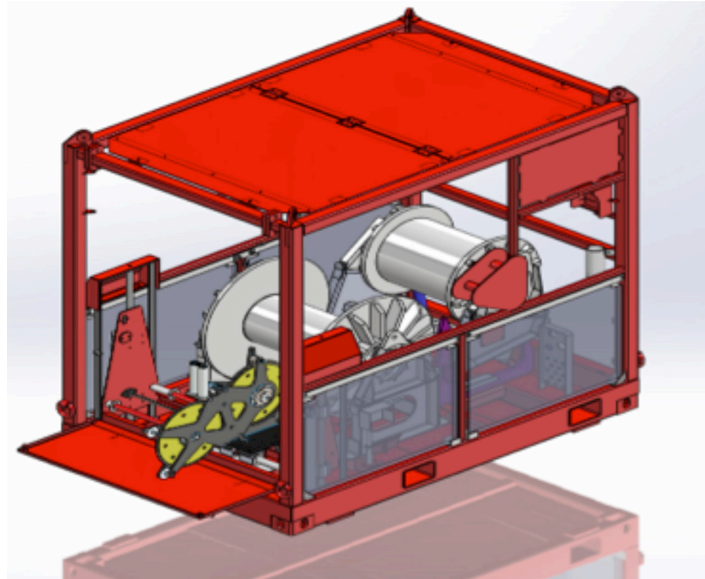

HAL50779

DIESEL POWER PACK

Diesel engine, 160HP@1,800 RPM,
0260KW generator for 220-AC voltage.

DNV 2.7-1 Certified Lift
Class 1 Division 2
Overall Size: 76 in. L x 40.5 in. W x 83 in. T
Actual Weight: 4,910 lb
Frame rated to: 13,000 lb

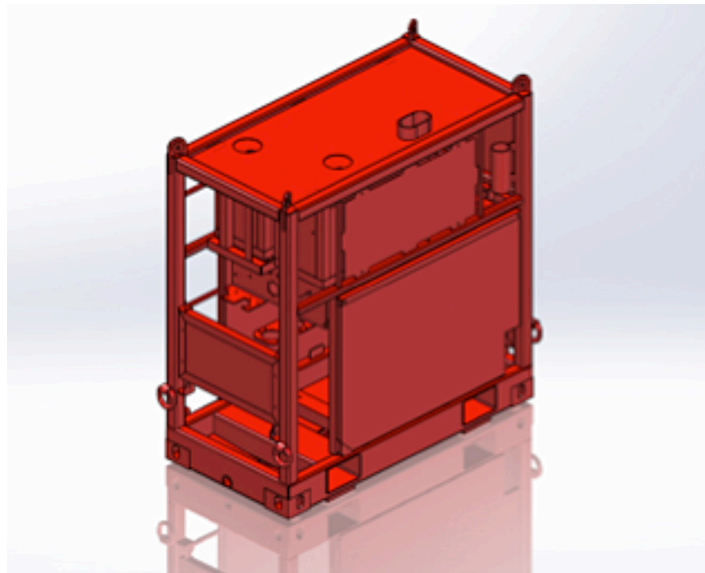

HAL50777

For more information, contact your local Halliburton representative or visit us on the web at www.halliburton.com

Sales of Halliburton products and services will be in accord solely with the terms and conditions contained in the contract between Halliburton and the customer that is applicable to the sale.

H012336 9/16 © 2016 Halliburton. All Rights Reserved.