

## 5.75 in Maxim® Dual String, Zinc Case, RDX 56.5 g Shaped Charge

Part No. 102184167

CE Certificate No.:

DOT EX No.: EX2004020380

### PROPER SHIPPING NAME

UN0059, CHARGES, SHAPED, 1.1D,  
PGII

### Technical Drawing

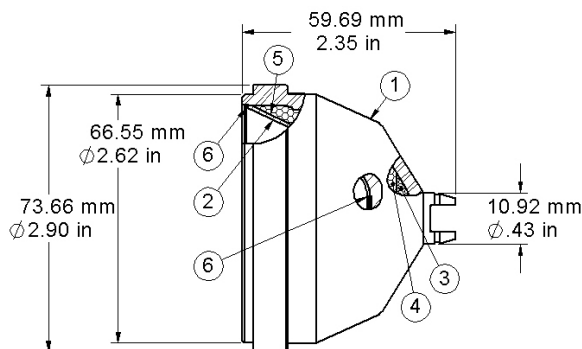

1. Case
2. Liner
3. Explosive, booster
4. Explosive, main
5. Paint
6. Glue ring

### Technical Information

#### APPLICATION:

Shaped charge for oilfield use.

#### PERFORATING SYSTEM

##### SPECIFICATION: (w/ cold drawn steel):

- Diameter: 5.75 inch (146.05 mm) OD
- Collapse rating: 21,000 psi (1,448 bar)
- Tensile rating: 512,000 lbs (232,239 kg)

#### EXPLOSIVES:

Booster: Pure RDX, 1g  
Main load: Desensitized RDX, 55.5 g  
Density: > 1.5 g/cm<sup>3</sup>

#### TEMPERATURE LIMITS:

325 F / 162 C 1 h  
260 F / 125 C 24 h  
225 F / 107 C 100 h

#### PERFORMANCE:

Manufacturing quality control data:

- Hole Diameter 1: 0.83 in (21.08 mm)
- Hole Diameter 2: 0.71 in (18.03 mm)
- Penetration: 9.20 in (233.43 mm)

#### SHELF LIFE:

10 years when stored unopened in original packaging. Storage temperature:  
0 C / 32 F min 54 C / 130 F max

#### DISPOSAL:

Dispose of product not suitable for oilfield use according to applicable laws and regulations.

### Packing Information

Quantity per box: 30 pieces  
Gross weight per box: 13.52 kg (29.8 lbs)  
Net weight per box: 9.70 kg (21.4 lbs)  
NEC per box: 1.6950 kg  
Box dim: 45.7 x 30.5 x 20.3 cm  
18 x 12 x 8 in

Package type: Trays with desiccant enclosed by vacuum bag, then placed inside fibreboard box.

Product Designation: Z503(P/N 102184167)

D00652637 Rev. A