

Ceiling Cloud

# Platter

Clouds of quiet

Soft forms drift overhead. With rounded edges and organic geometry, shapes intersect, overlap, and gather like clouds in motion. Installed in layered compositions or expansive fields, Platter reshapes the acoustic atmosphere while creating sculptural ceilings that immerse you in quiet.



Image by Imperfect\*

# How To Specify

**Key Information**

Platter can be configured in a variety of ways to suit your space. Consider the following as you design your layout.

If shop drawings are required for your project, please follow steps 1 - 6.

**Fast Track**

If you're looking to expedite your project, this product is available as Turf Fast Track!

Using Fast Track, our standard lead time for shop drawings is eliminated allowing the project to move directly into production.

Please note: installation and seaming drawings are not included in this process.

Turf recommends 10-15% additional panels to cover overage / attic stock.

**Standard Shapes**

Only Standard Shapes at the listed dimensions are available through Fast Track.

See "Standard Shapes" page for more information.

**1**

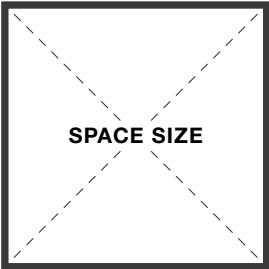

What are the dimensions of your space?

**2**

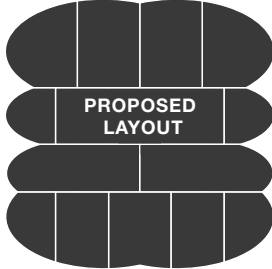

What is your proposed layout?

PAGE 3

**3**

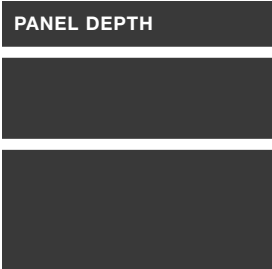

What panel depth do you need?

PAGE 3

**4**

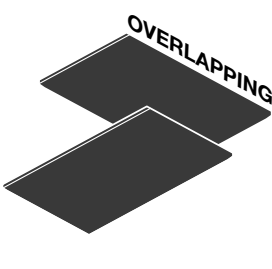

Are panels overlapping in your layout?

PAGE 6

**5**

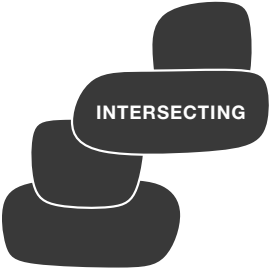

Are panels intersecting in your layout?

\*Knife Edge detail required

PAGE 7

**6**

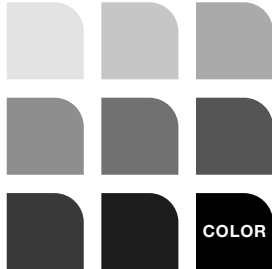

What is the color, grain or texture of tiles?

PAGE 15-18



1. Which Standard Shapes do you need?
2. What color, texture or grain?
3. How many panels do you need?
4. Do you want to include any additional product for overage or attic stock?



## Dimensions

Variable Length	12"L Min - 116"L Max
Variable Width	12"W Min - 44"W Max
Variable Depth	2"D Min - 6"D Max
Standard Depths	2"D, 4"D, 6"D

## Standard Shapes

Fast Track	Turf offers a range of standard shapes with set dimensions available for Fast Track.  See our "Standard Shapes" page for more information.
------------	--

## Connection

Cable Hung	Cable To Deck  See our "Connection" page for more information.
------------	--

## Color

9mm Palette	Platter can be specified in any of our 9mm felt colors, Grains or Textures.
Color Match	UV ink creates colorful possibilities for Turf's felt. The acoustic performance isn't affected by printing.

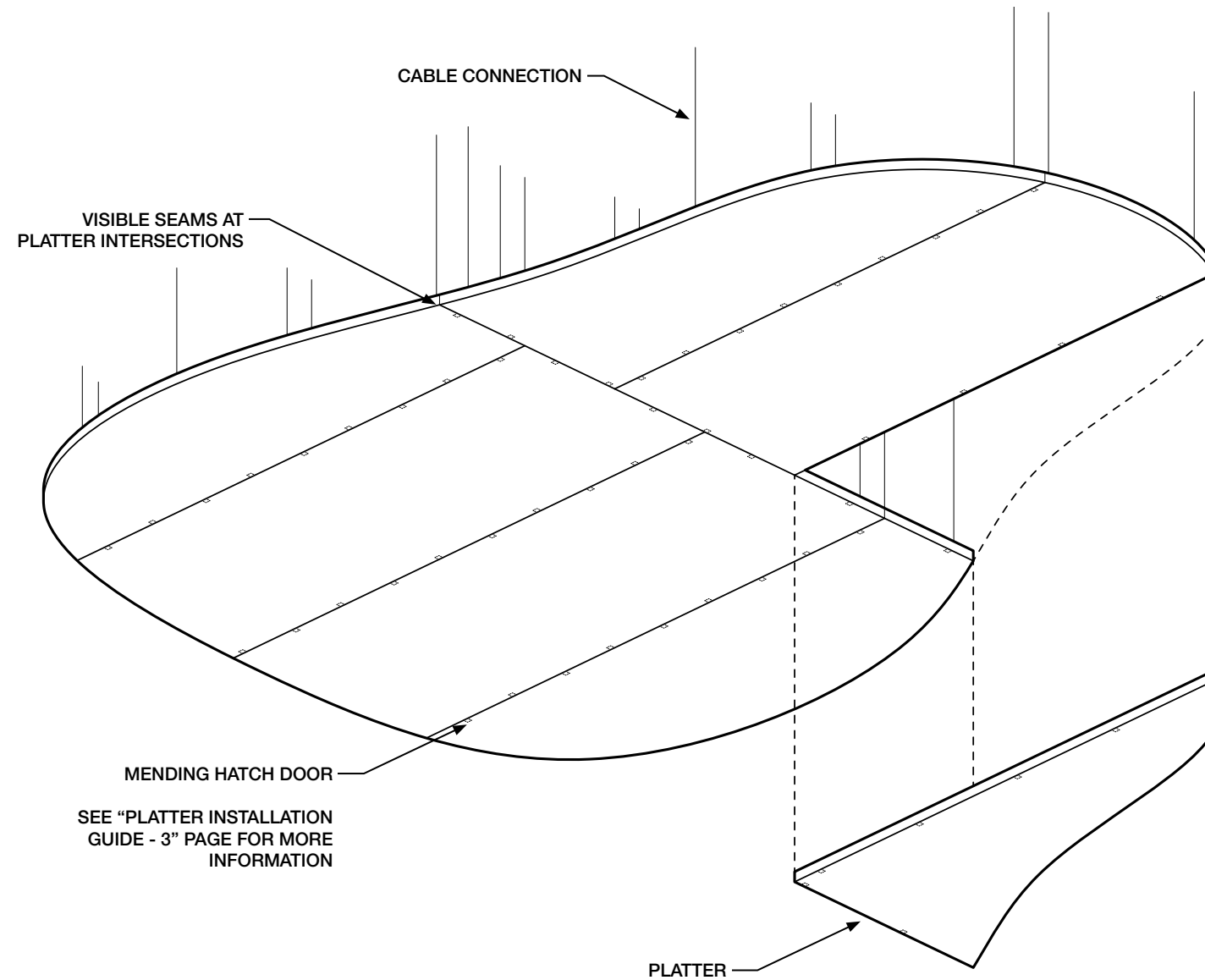

## SHAPE TYPES

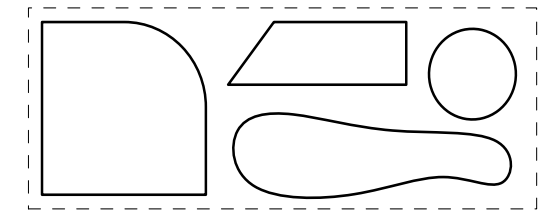

Organic shapes and polygons, oh my!  
Almost any shape is possible with the Platter construction, please follow general rules below.

## CUSTOM SHAPE MINIMUMS

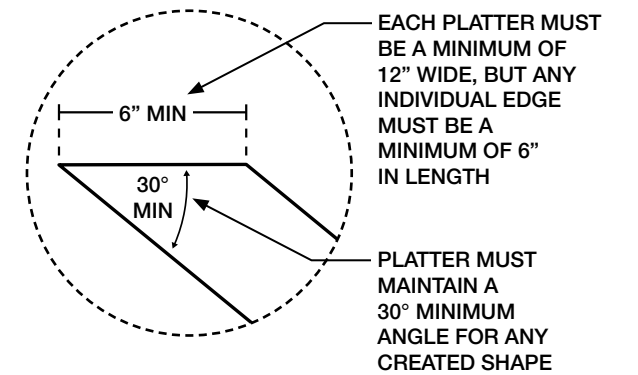

## INTERIOR RADIUS MINIMUM

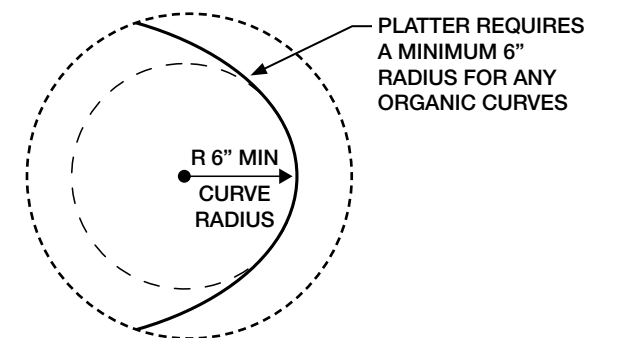

ALL DIMENSIONS NOMINAL UNLESS NOTED OTHERWISE

# Standard Shapes

## Fast Track

Platter's standard shapes provide a beautiful and efficient ceiling solution. The shapes and sizes listed below are available for Fast Track, allowing your project to move directly into production.

## 1" Gap Between Panels

Standard shapes do not include mending hatch door locations. Turf recommends maintaining a minimum 1" gap between adjacent panels when developing your layout.

## Cardboard Layout & Connections

Turf will supply cardboard layout templates with each standard shape. These templates indicate recommended connection locations that can be used as pick points.

Connections can be adjusted in field as required. See best practices for moving connections on the following page.

### RECTANGLE

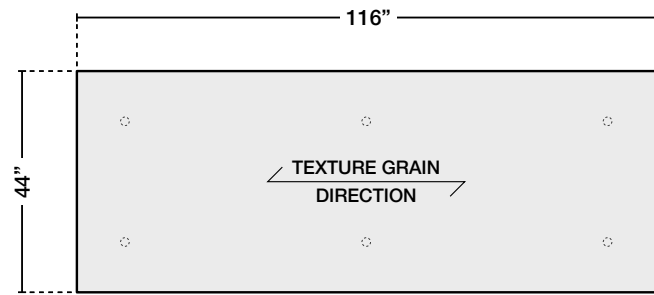

### WEDGE

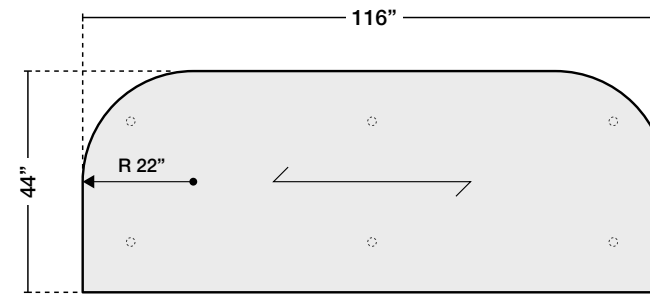

### SQUARE

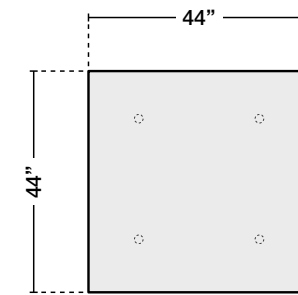

### CIRCLE

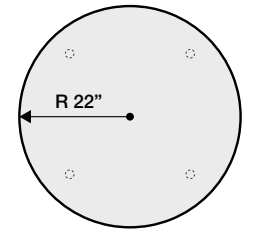

### WINDOW

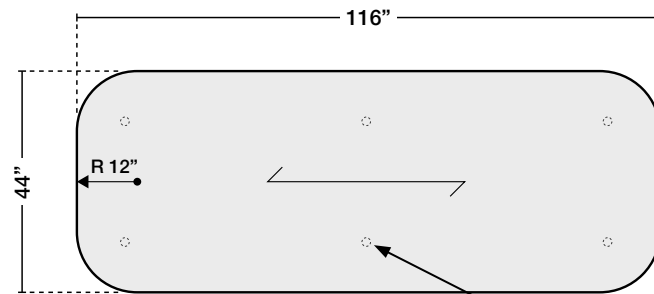

### ARCH

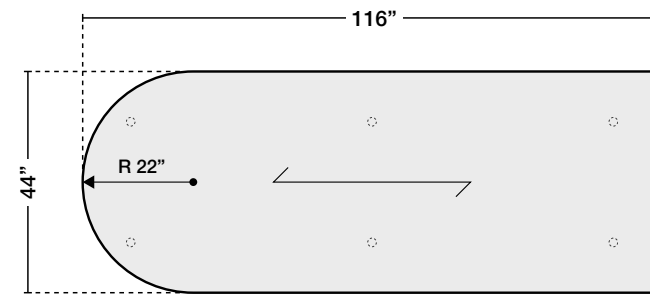

### BUTTON

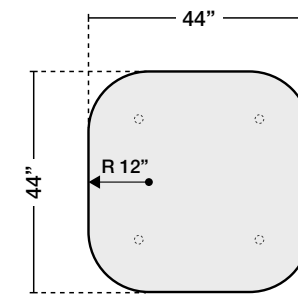

### DOT

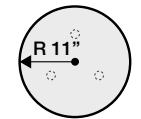

### PILL

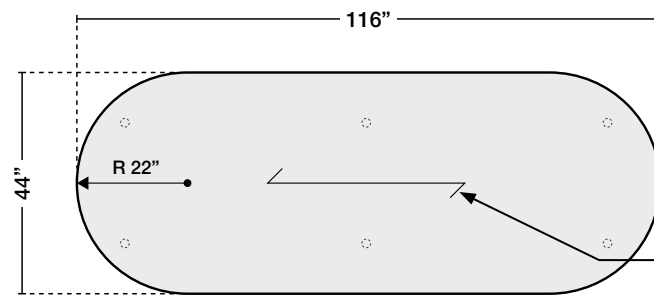

CABLE CONNECTION LOCATION, TYP.

ON LARGE SHAPES THE TEXTURE GRAIN DIRECTION RUNS THE LENGTH OF THE PANEL

\*DOT ONLY USES THREE CONNECTIONS ON THE BACK OF THE PANEL, ALL CABLES ARE HUNG FROM A SINGLE CABLE PUCK AT THE CENTER

## Dimensions

44"W x 116"L x 2"D

Rectangle  
Window  
Pill  
Wedge  
Arch

44"W x 44"L x 2"D

Square  
Button

R 22"

Circle

R 11"

Dot



# Connection

## Connection Spacing

48" OC Max

Spacing varies per project. Platter requires a minimum of four connection points, number of connections will vary per panel and project.

## Cable To Deck

Panels with cable grippers snap into deck-mounted aircraft cables.

10' aircraft cable supplied by Turf should be trimmed in the field as needed.

## Stiffener Matrix

The top side of each Platter panel includes a matrix of indentations that add structural strength. The stiffener pattern varies by panel shape and size.

## Connection Adjustment

Connections can be adjusted in the field, provided they comply with maximum OC spacing and cantilever limits.

Connections cannot be relocated within the indentation areas.

See our "Platter Installation Guide - 2" page for more information on adjusting connections in field.

PLATTER BOTTOM

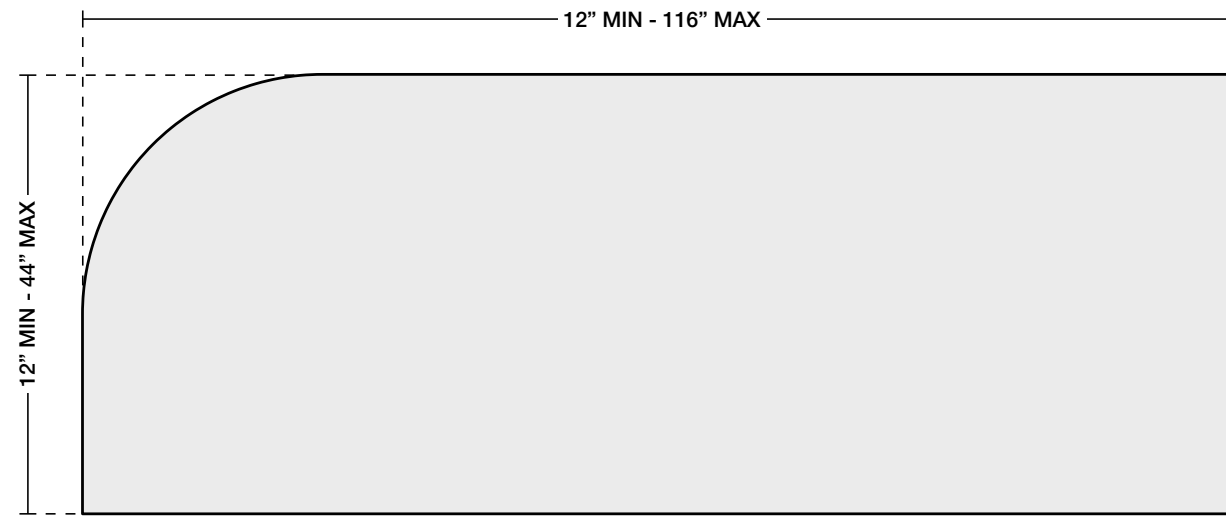

PLATTER FROM BELOW

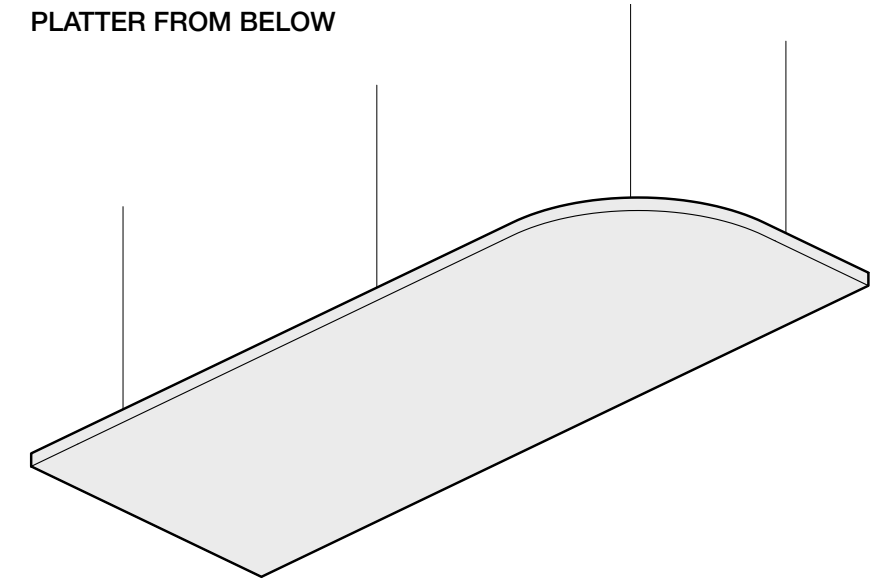

PLATTER TOP

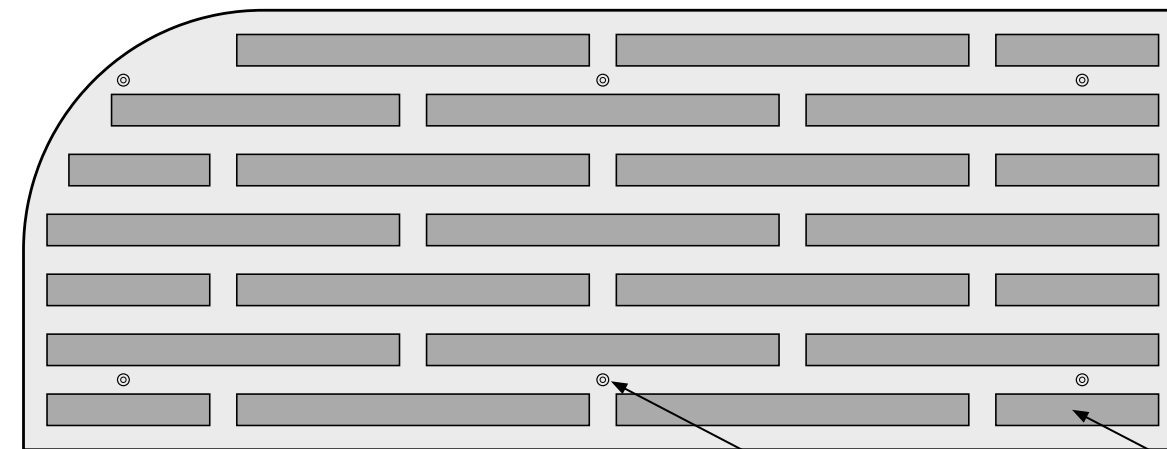

CONNECTION POINTS CAN BE ADJUSTED IN FIELD, NEVER MOVE A CONNECTION INSIDE AN INDENTATION

INDENTATION

PLATTER FROM ABOVE

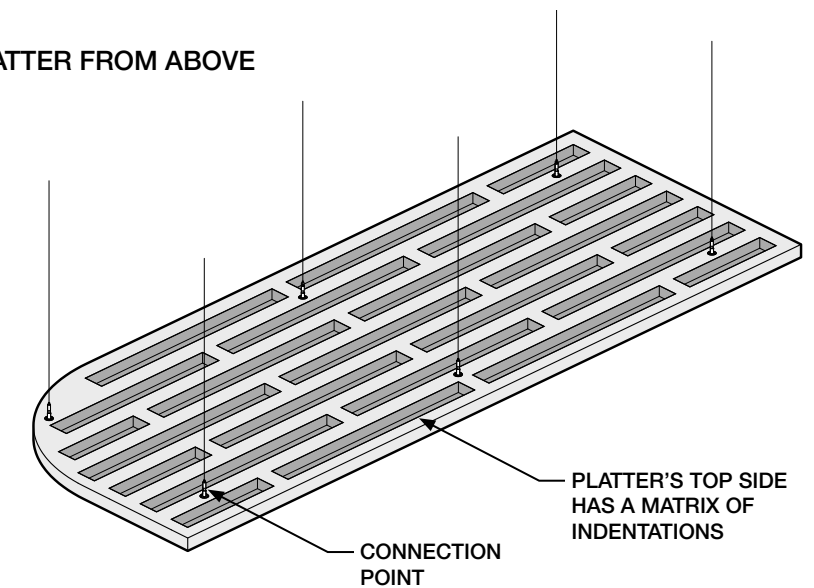

PLATTER ELEVATION

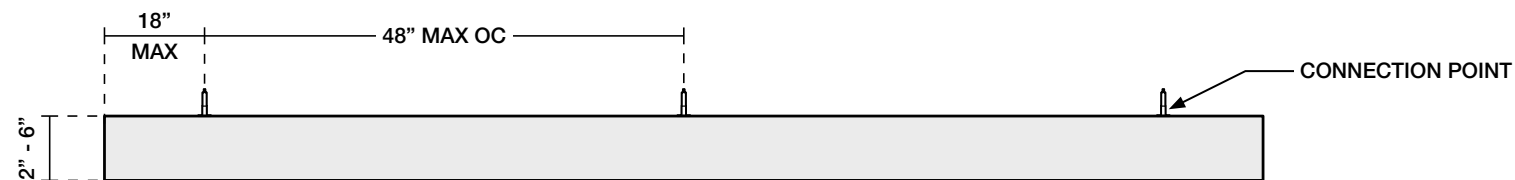

# Overlapping Platter

**Coordination with Turf**

Layering Platter offers designers infinite opportunities for creative compositions.

Turf recommends coordinating with our in-house team and completing the shop drawing process to address the complexities of layered layouts.

**Standard Shapes**

When creating overlapping arrays using Fast Track standard shapes, cable locations and additional coordination will need to be completed in the field.

Follow the details on this page, as well as the "Platter Installation Guide" for more information on field coordination.

**OVERLAPPING PLATTER EXAMPLE**

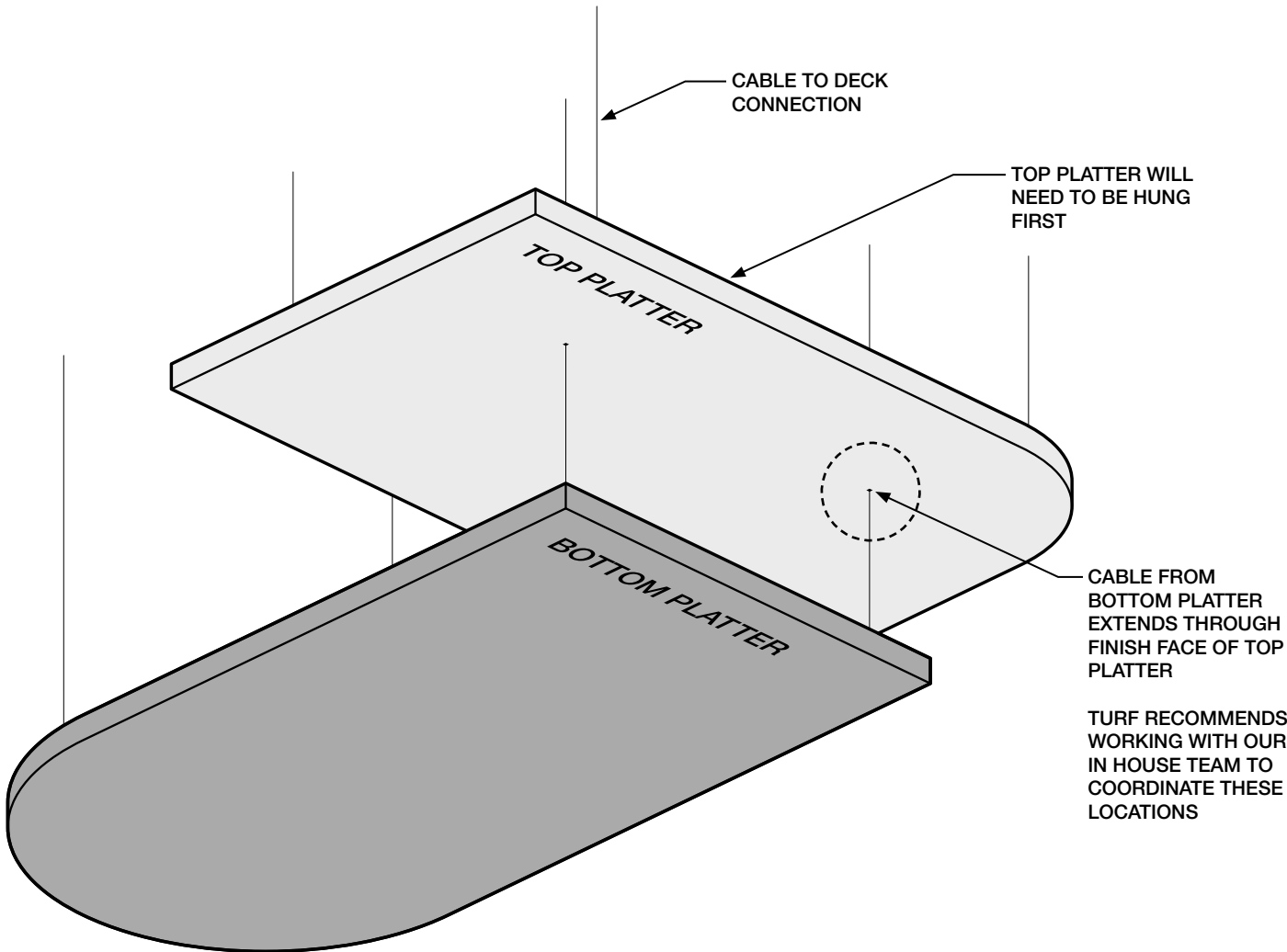

**CABLE MINIMUM DETAIL**

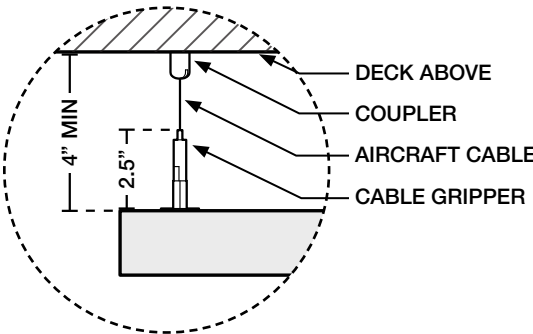

**CABLE THROUGH PLATTER DETAIL**

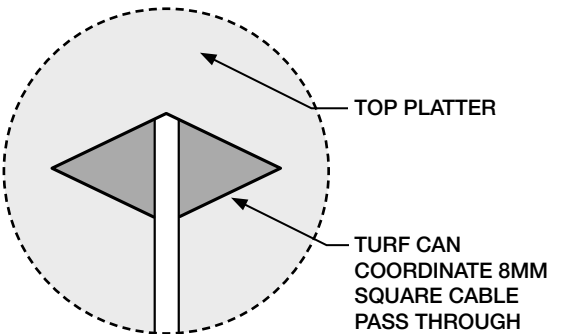

IF FAST TRACKING TURF PRODUCT, USE A 1/4" DRILL BIT TO CREATE PASS THROUGH



# Intersecting Platter

- Coordination with Turf**  
 All intersecting Platter installations must be coordinated with Turf's in-house design team.
- Depth Difference**  
 Adjacent intersecting panels must have a minimum 2" difference in their respective depths.
- Intersection Minimum**  
 Intersecting panels require a minimum 6" overlap.
- Intersection Platter Installation**  
 Intersecting Platter installations follow a different process than traditional installations.  
  
 See our "Platter Installation Guide - Intersecting" page for more information.

## INTERSECTING PLATTER EXAMPLE

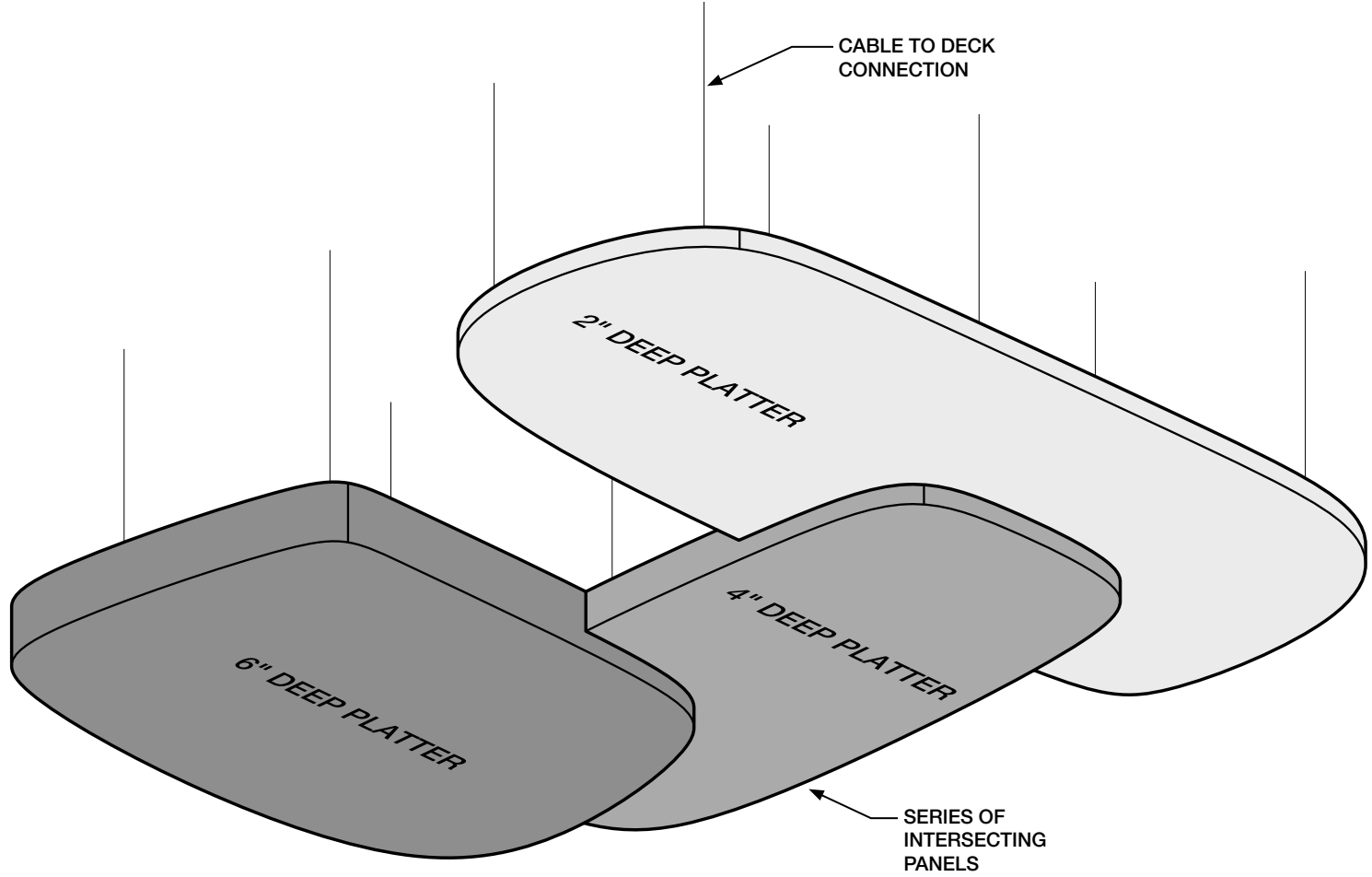

## DEPTH DIFFERENCE MINIMUM

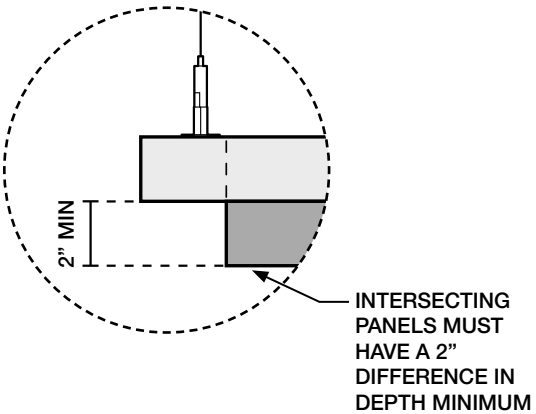

## INTERSECTION MINIMUM

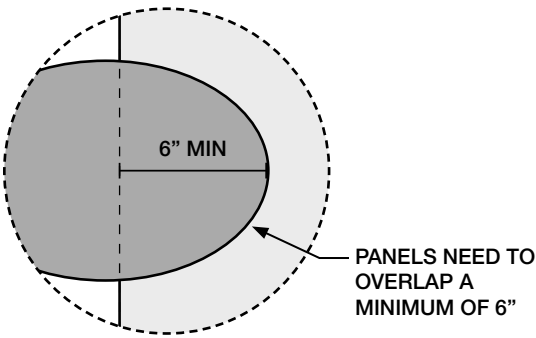

# Texture & Grain Considerations

**Pattern Direction**  
 All of Turf's Wood Grains, Wood Textures, and Travertine Stone Textures have an inherent pattern direction. When using these finish options, consider the following.

**Pattern Along Curves**  
 Our Grains and Textures flow in a single direction, meaning they will not follow along with the curves of an organic shaped panel.  
 See the "Curved Platter with Texture" drawing for details.

**Pattern Around Edge**  
 Grains and Textures will flow horizontally around the edge of all Platter panels.  
 See the "Pattern Direction Along Edge" detail for more information.

**CURVED PLATTER WITH TEXTURE EXAMPLE**

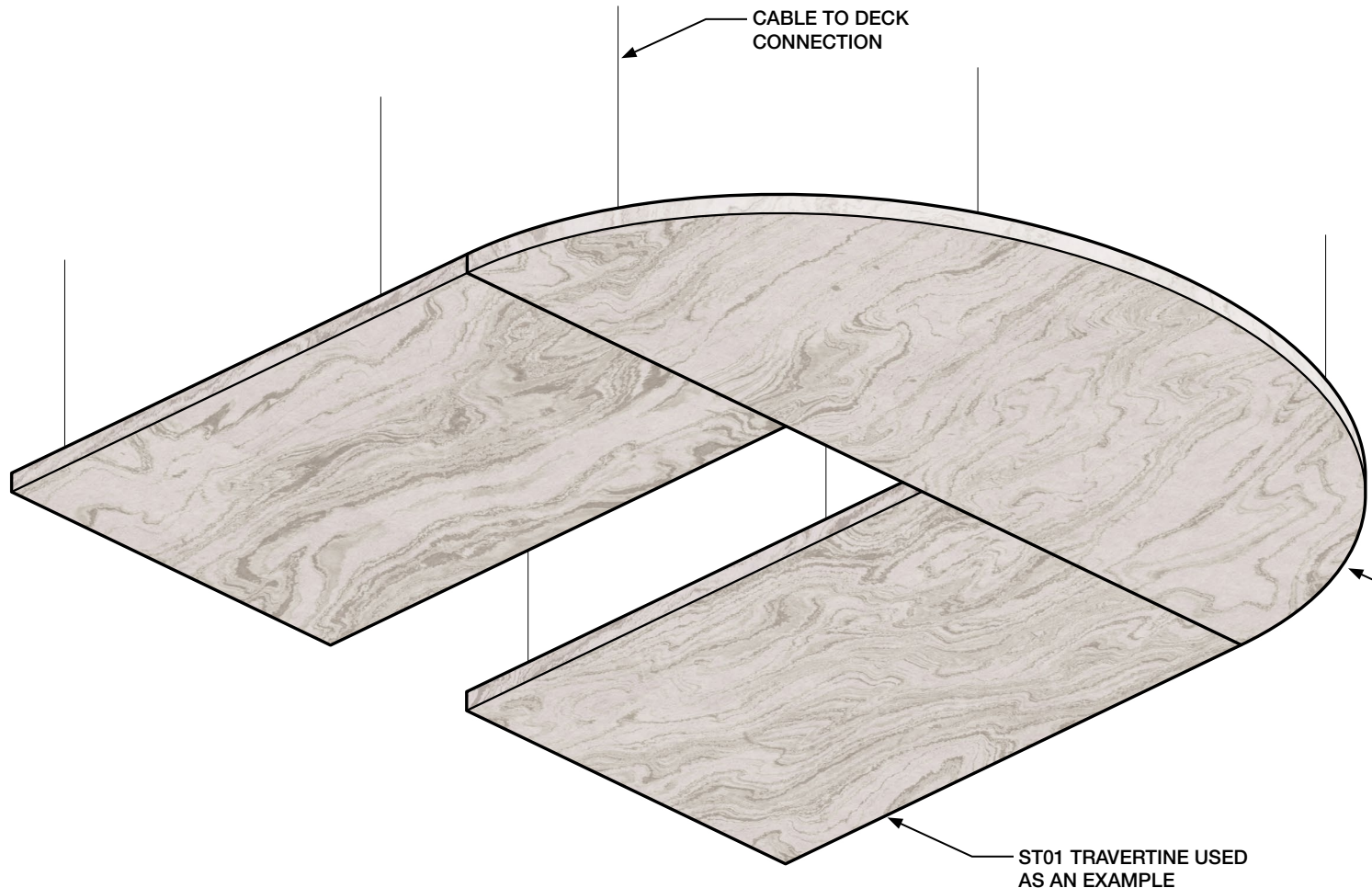

**PATTERN DIRECTION ALONG EDGE**

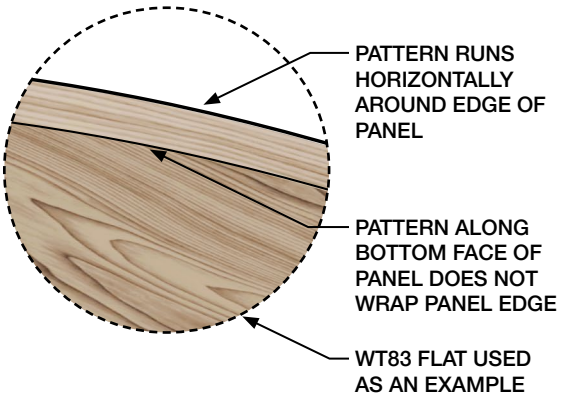

TEXTURE FLOWS IN A SINGLE DIRECTION AND WILL NOT FOLLOW PANEL CURVES

ST01 TRAVERTINE USED AS AN EXAMPLE



# Platter Installation Guide - 1

## Cardboard Layout

Turf supplies cardboard templates to help during Platter installation.

Cardboard templates show product outline, Platter tags and cable locations ensuring reliable and efficient installation.

Reference Turf shop drawings for detailed information on how to install Platter.

## Tools Required

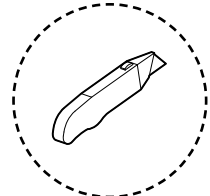

SHARP BLADE

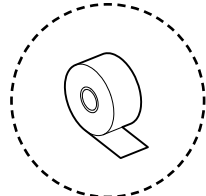

ROLL OF TAPE

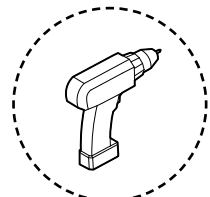

DRILL

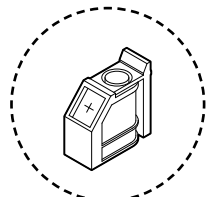

LASER

### 1 - CARDBOARD LAYOUT PROVIDED BY TURF

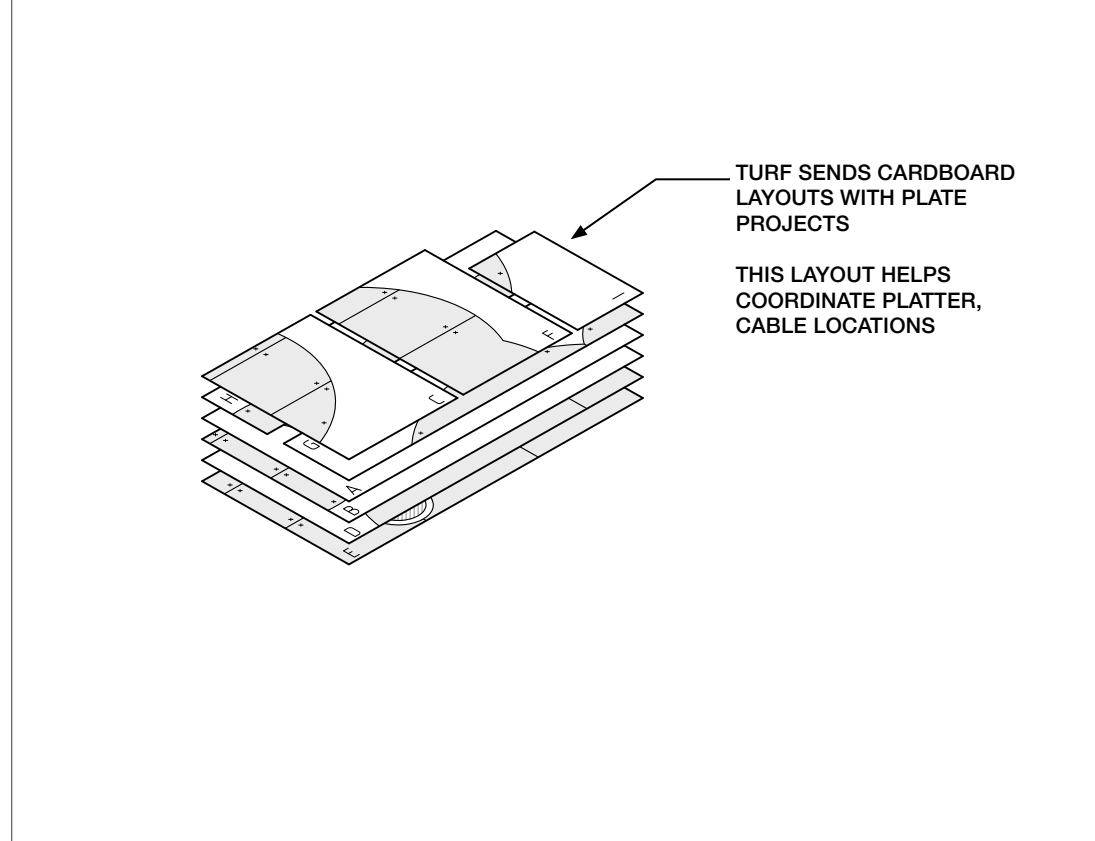

### 2 - CARDBOARD LAYOUT DETAILS

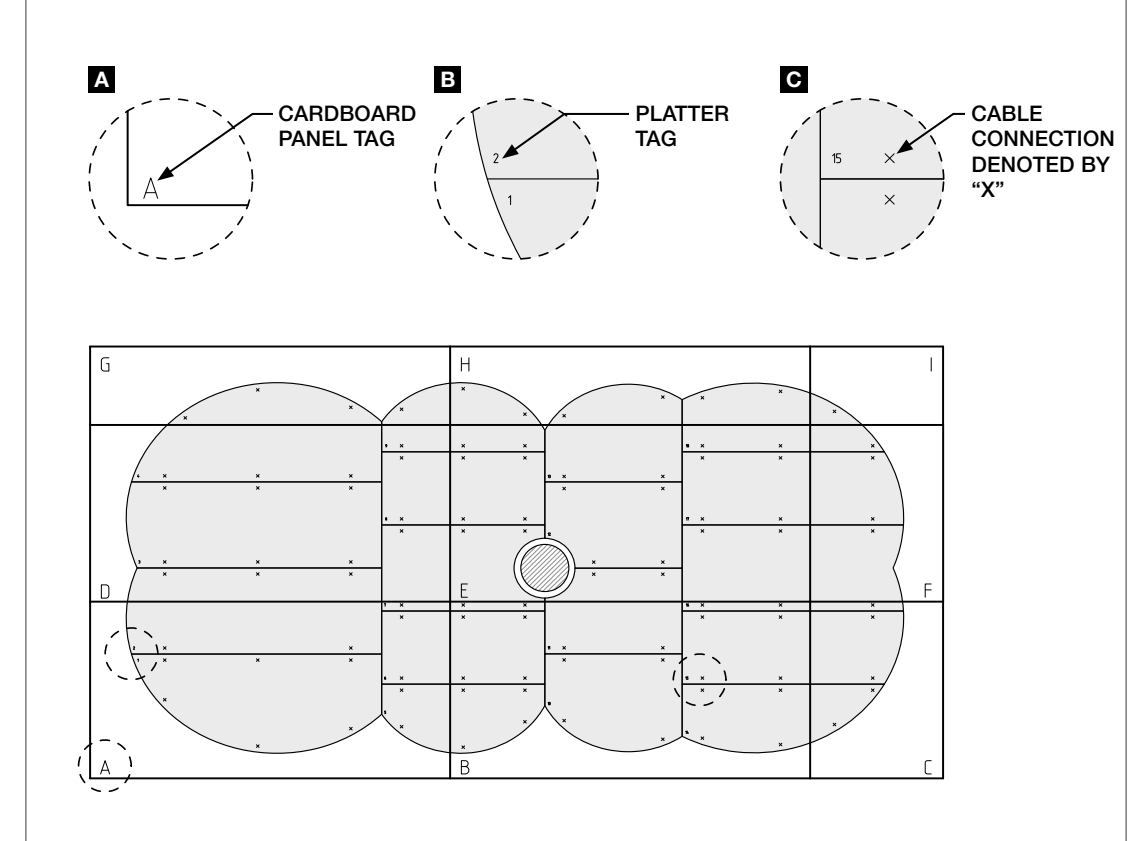

### 3 - UNPACK AND LAYOUT CARDBOARD

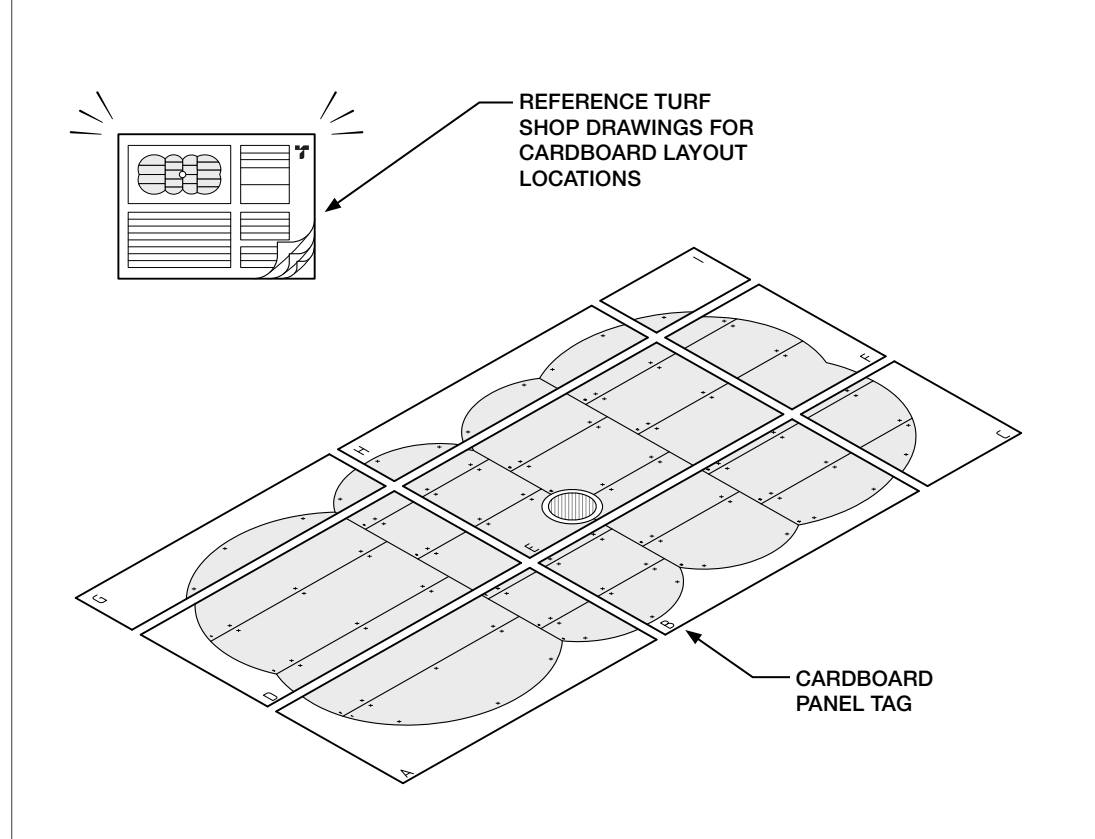

### 4 - FIELD TRIM AROUND OBSTRUCTIONS AS REQUIRED

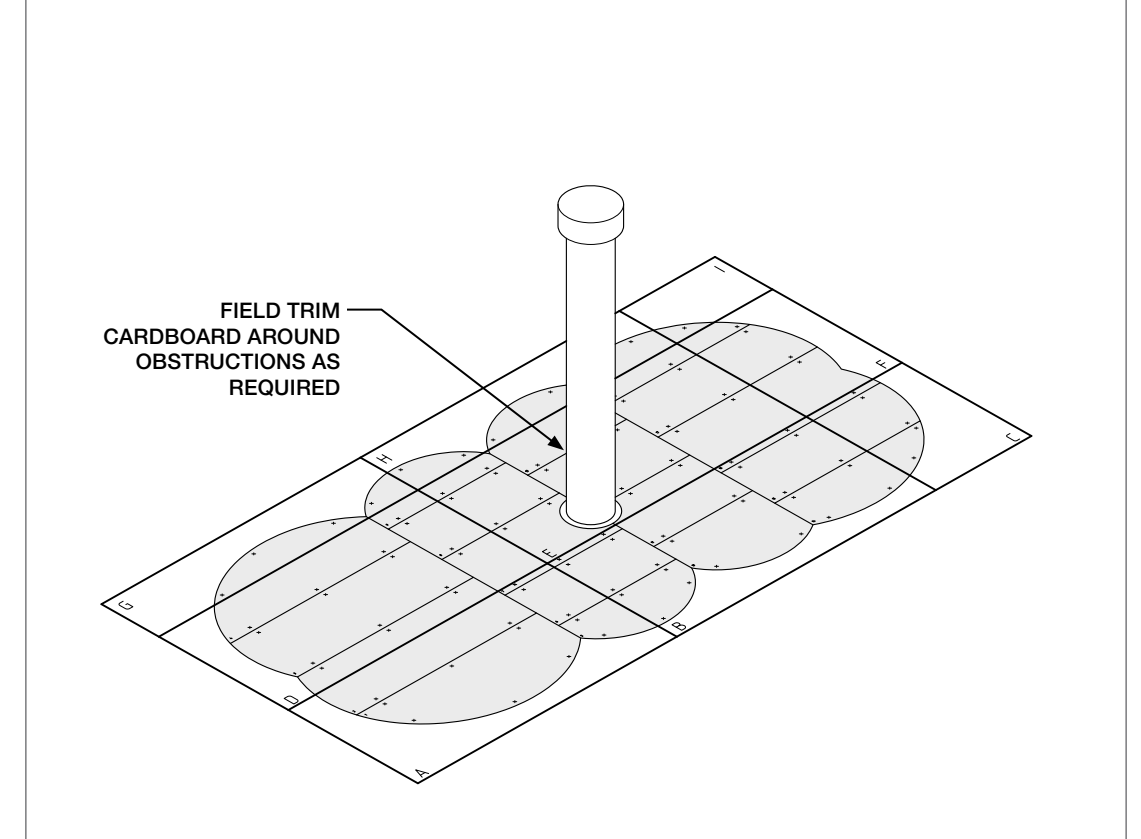

# Platter Installation Guide - 2

## Pick Points

Once the cardboard template is installed in the space, place a laser on each individual connection point which will give you the correct location to mount the cable coupler to your ceiling. "X" marks the spot.

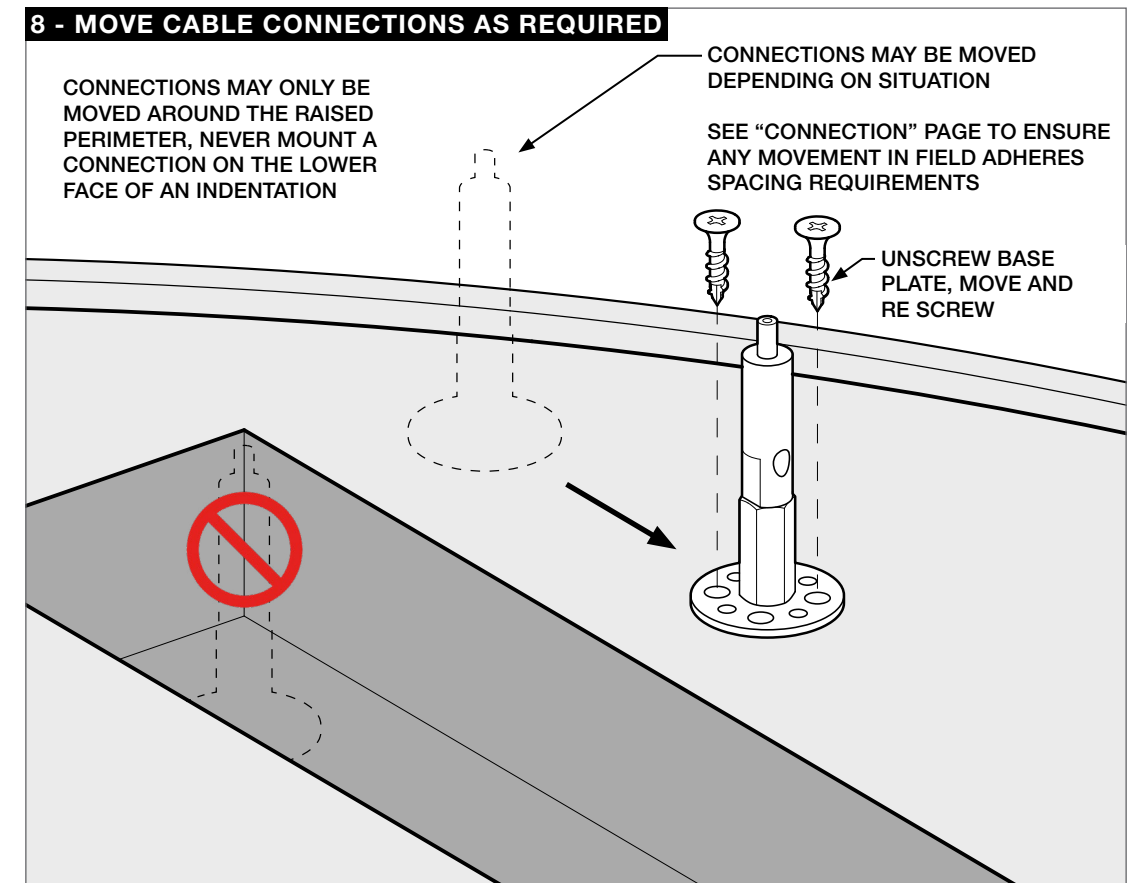
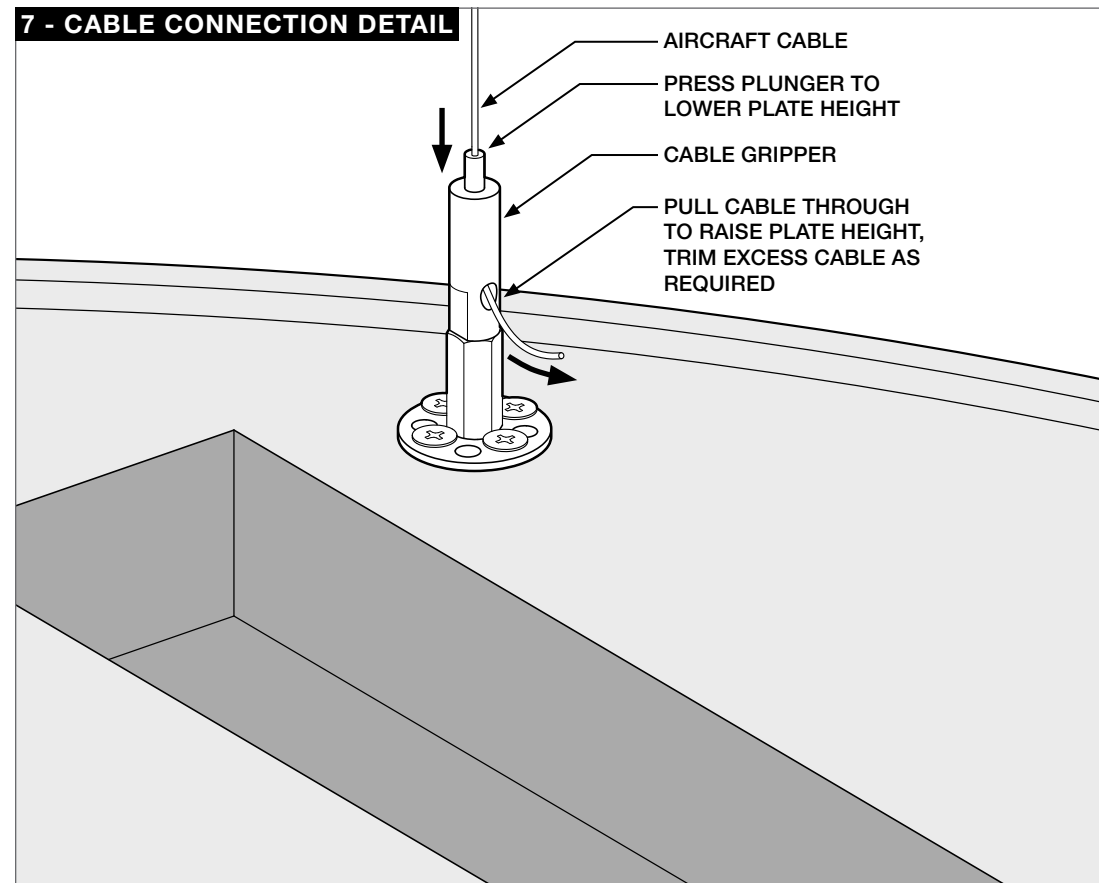
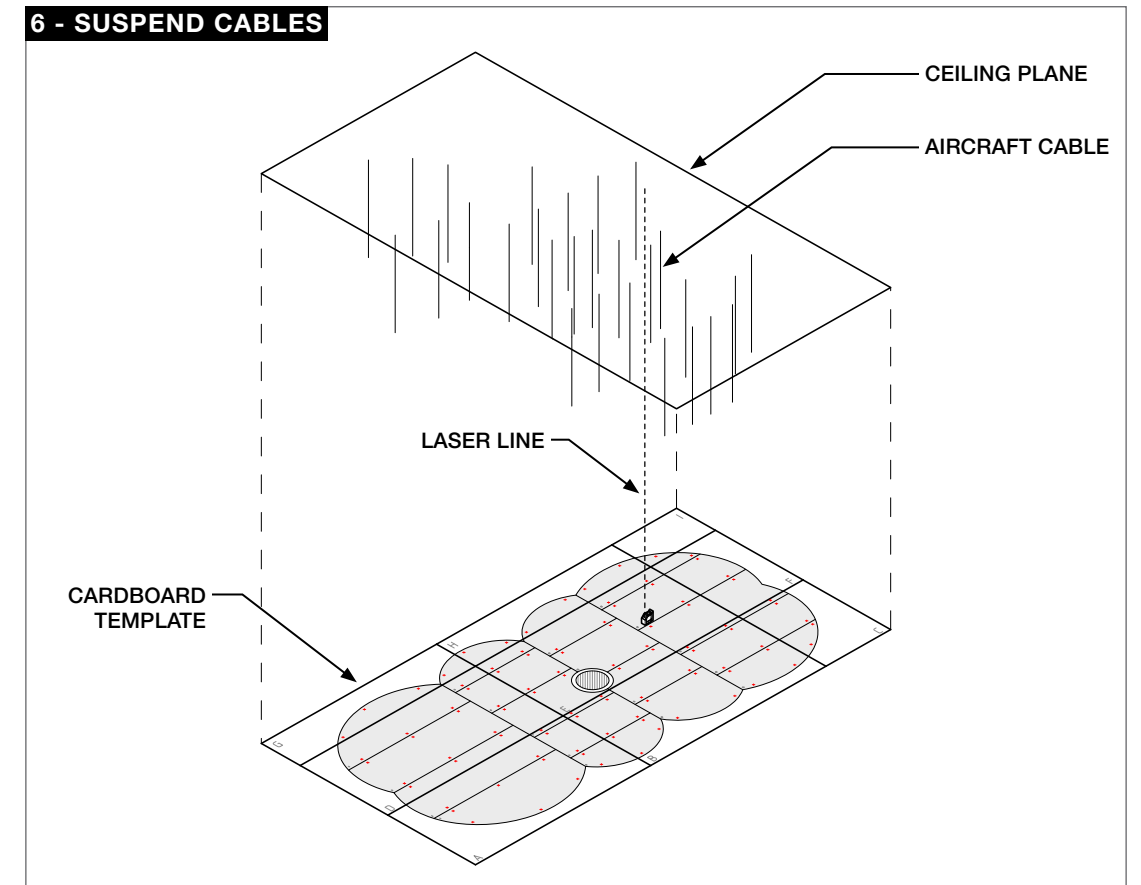
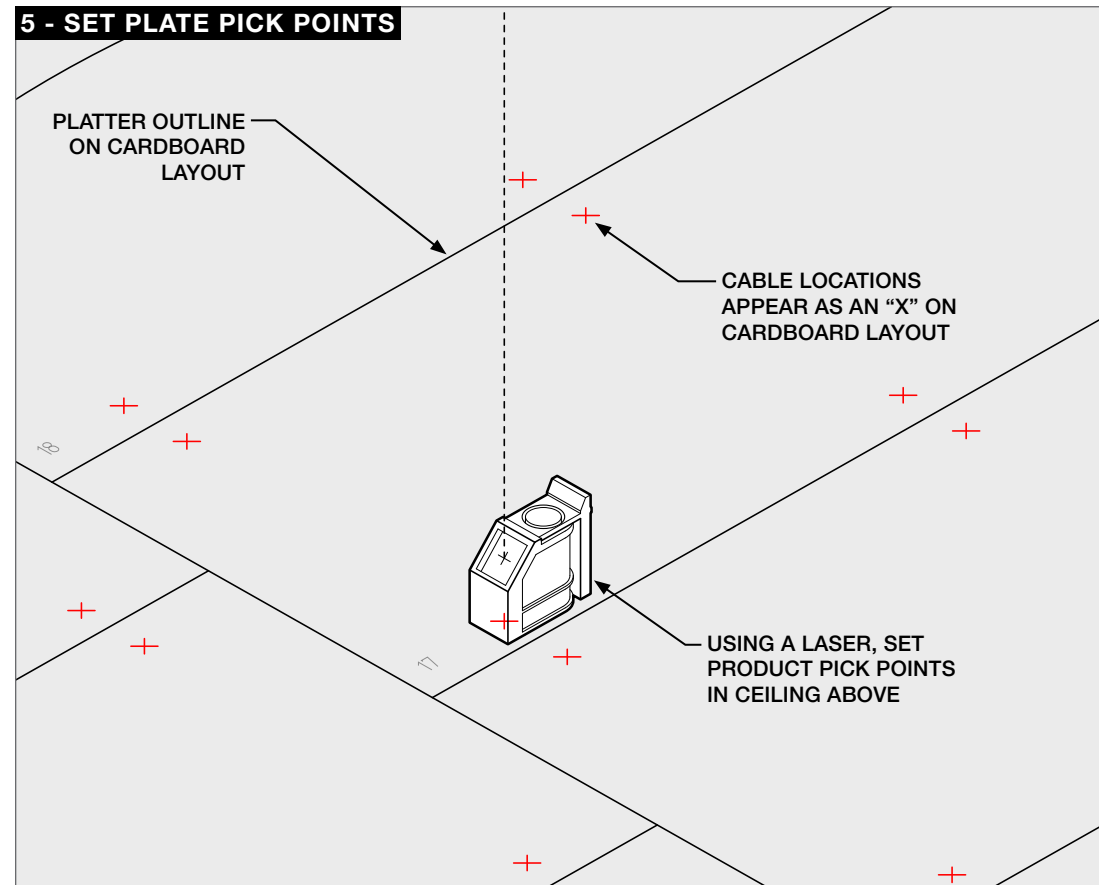

# Platter Installation Guide - 3

## Mending Hatch Doors

Adjacent Platter panels include a system of hatch doors along their seams. These can be opened to allow installers to fasten panels together, creating a tight seam.

## Hatch Doors Spacing

Hatch doors are typically spaced 12" OC and staggered on either side of the seam being joined. Spacing may be adjusted depending on specific project conditions.

## Opening Hatch Doors

The back of Platter panels include holes where installers can poke doors open using a flat head screwdriver or other flat tool.

Do not use a knife or sharp tool to open or close hatch doors.

## Hatch Doors Seams

Hatch doors are 1" squares and are nearly invisible once panels are installed in the ceiling, see images below.

Hatch Door Open Photo



Hatch Door Closed Photo



### 9 - RAISE ADJACENT PANELS INTO PLACE

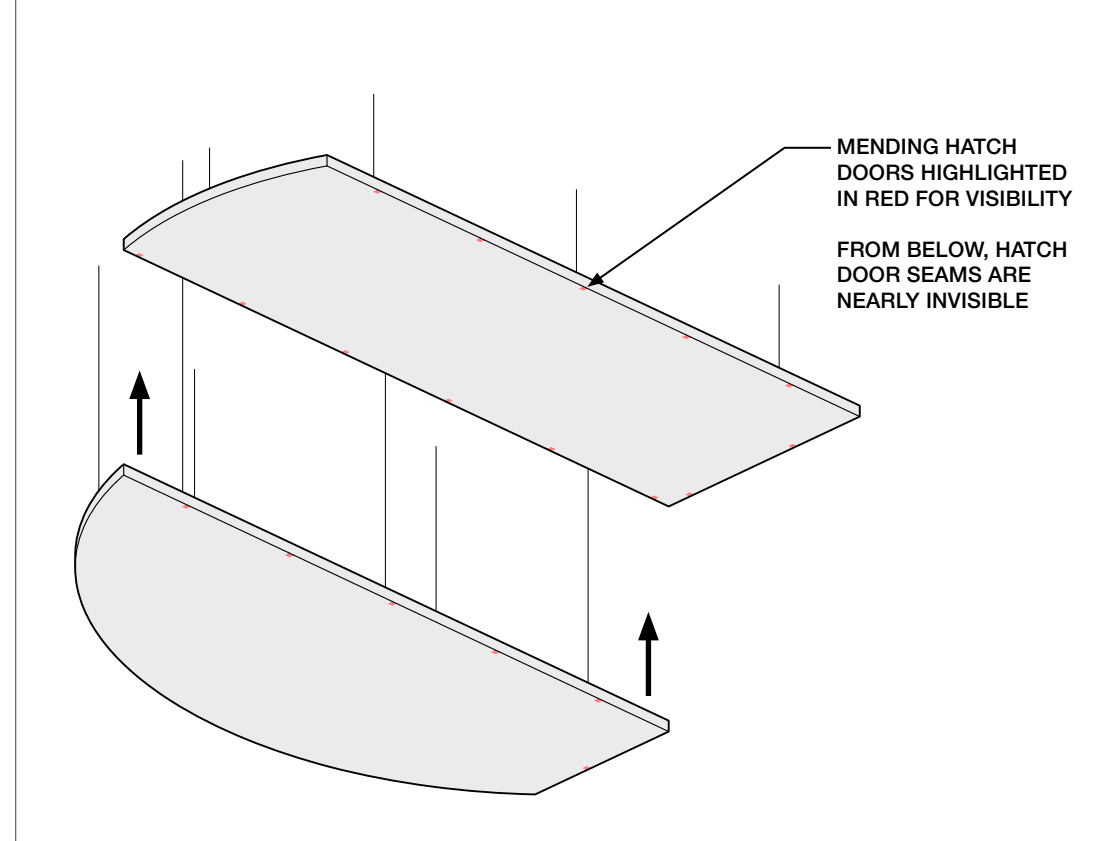

### 10 - MENDING DOOR SPACING

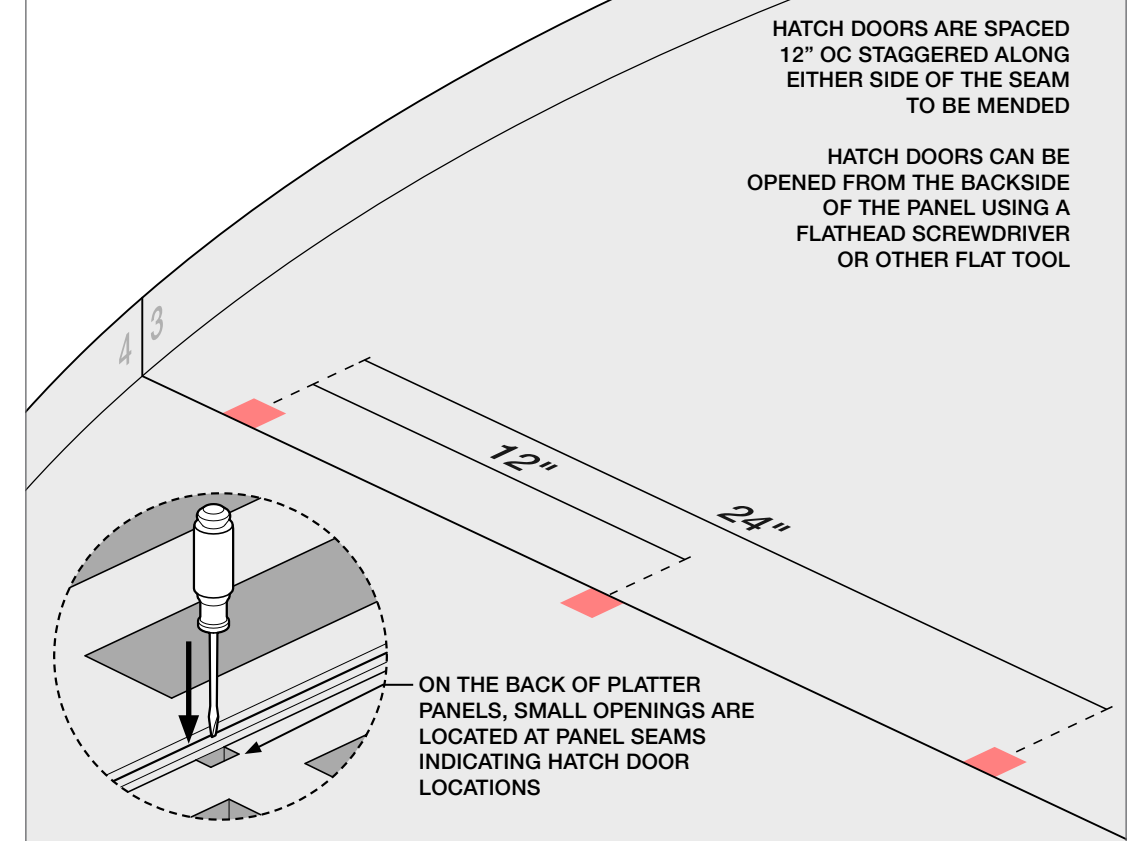

### 11 - SCREW ADJACENT PANELS TOGETHER

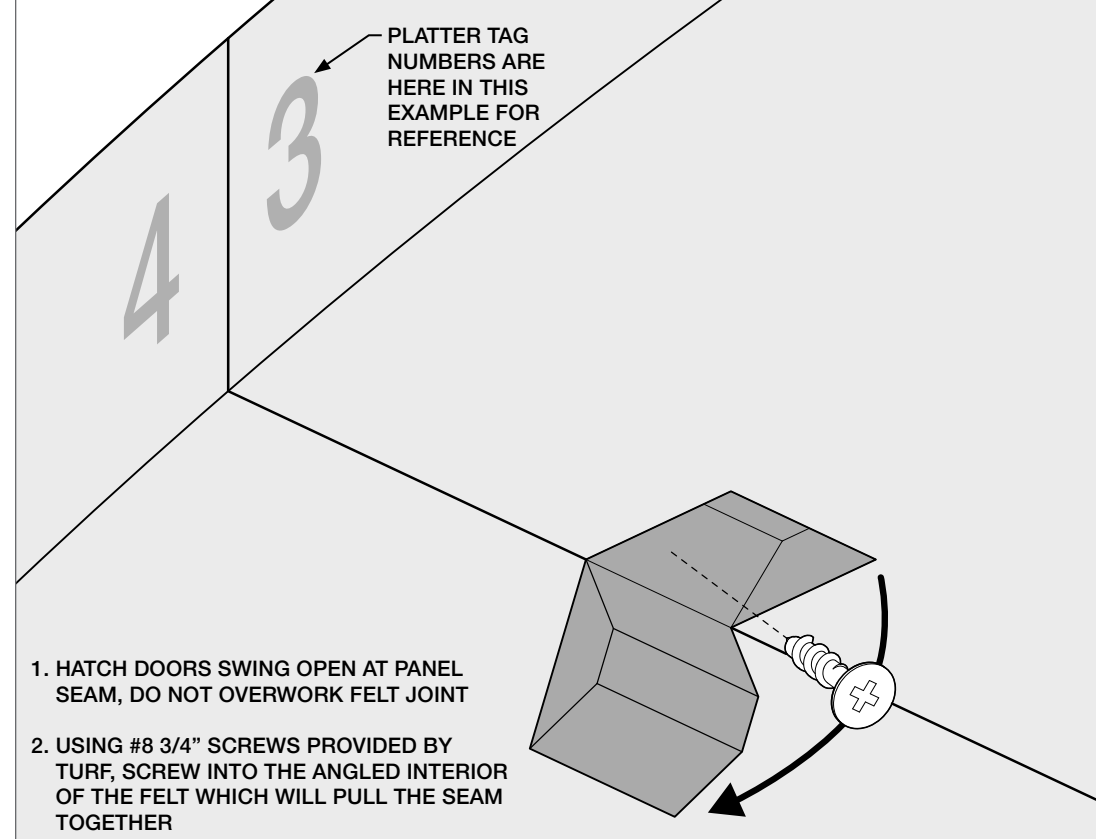

### 12 - CLOSE HATCH DOOR, SMOOTH SEAM

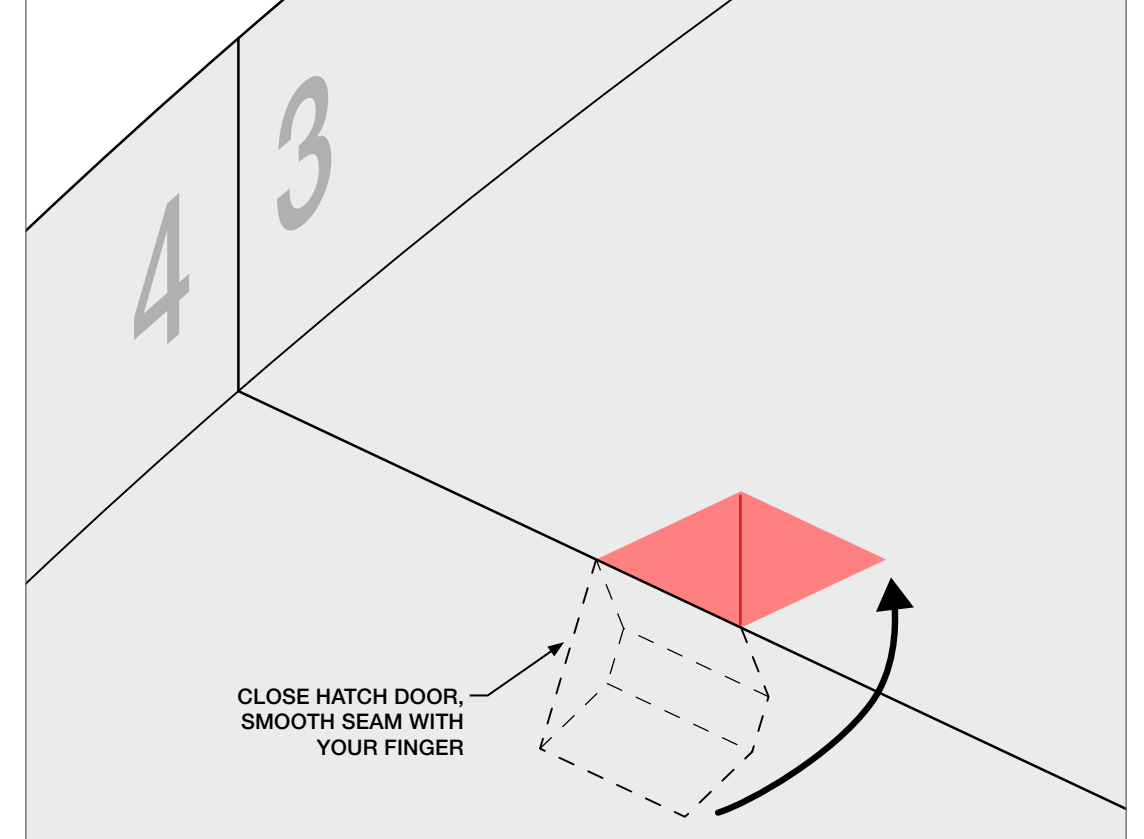

# Platter Installation Guide - Intersecting

## Previous Steps

Follow steps 1-8 in the previous Installation Guide pages. Skip the "Platter Installation Guide - 3" page, as Intersecting Platter does not include mending hatch doors.

## Hanging Sequence

For intersecting installations, panels must be installed in the correct sequence.

Panels positioned behind the overlap should be hung first.

## Stiffener Matrix

The back side of Platter panels includes a series of indentations in a running bond pattern that provide added rigidity.

When fastening through these areas, take care to ensure screws do not penetrate the front face of the panel.

### 9 - RAISE ADJACENT PANELS INTO PLACE

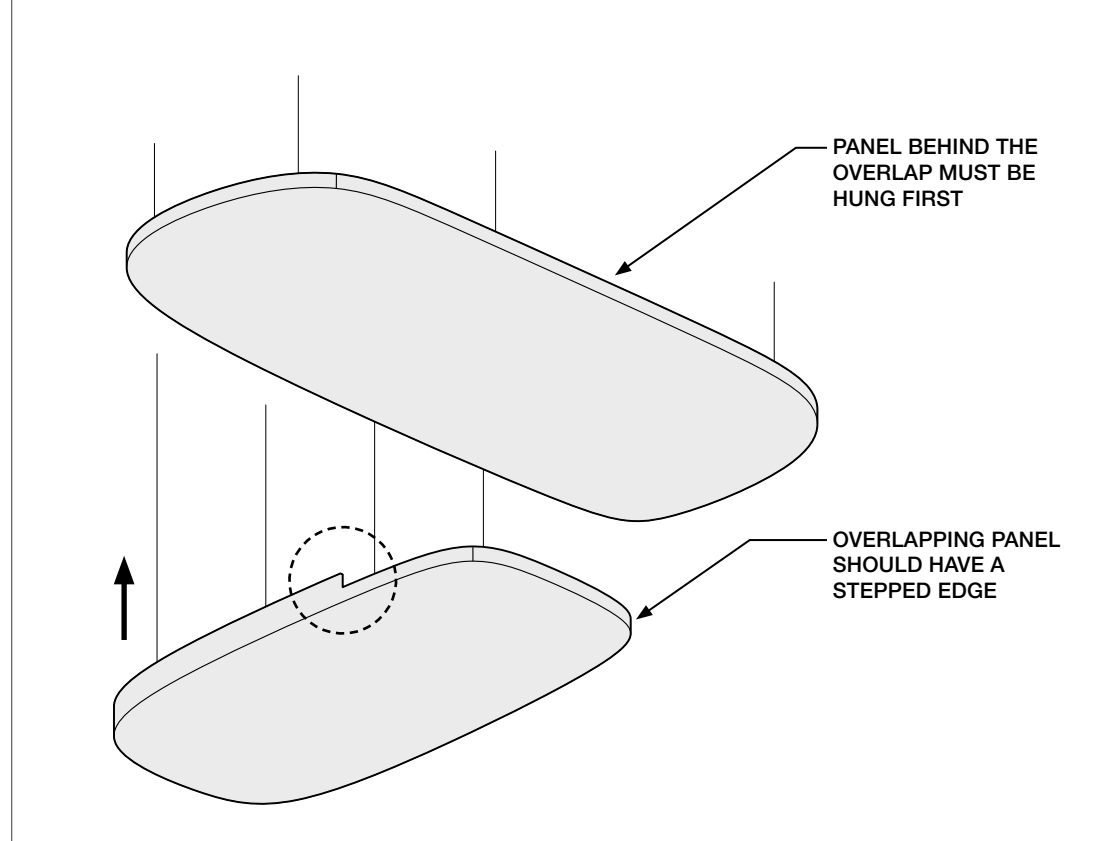

### 10 - OVERLAP ZONE

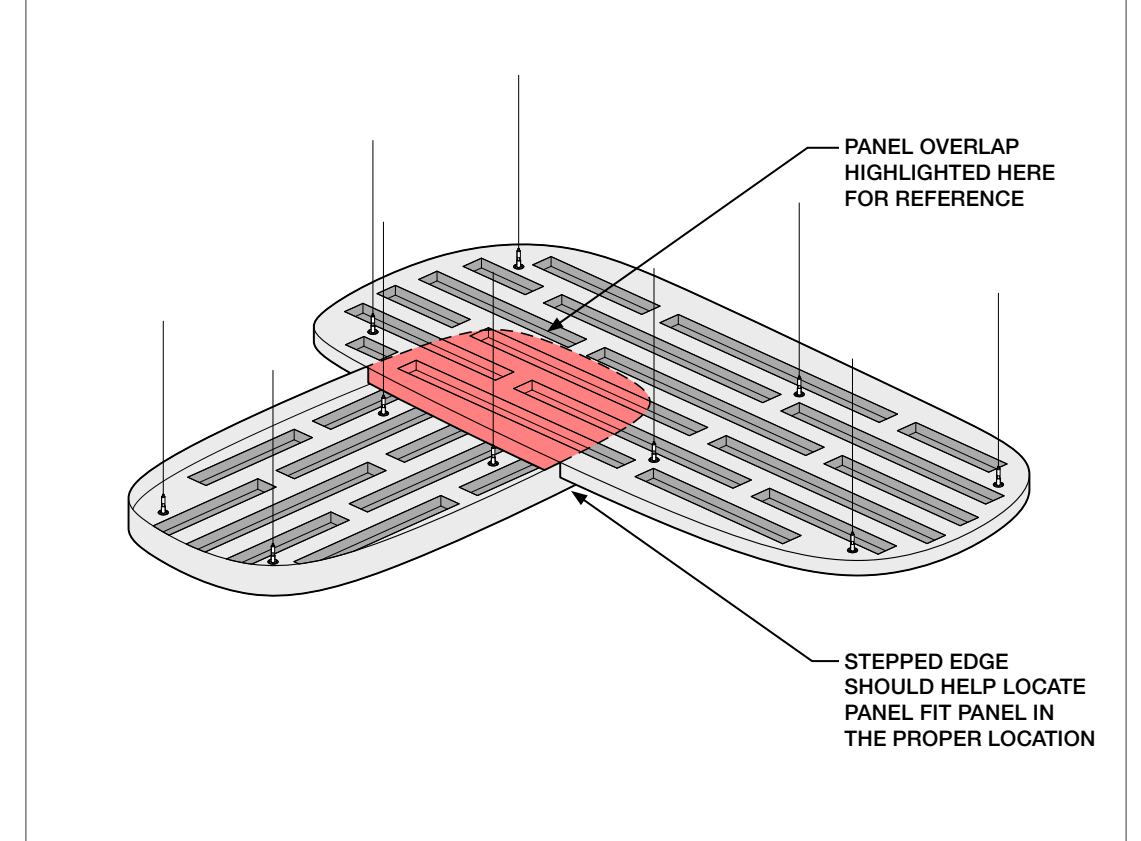

### 11 - SCREW THROUGH TOP PANEL INDENTATIONS

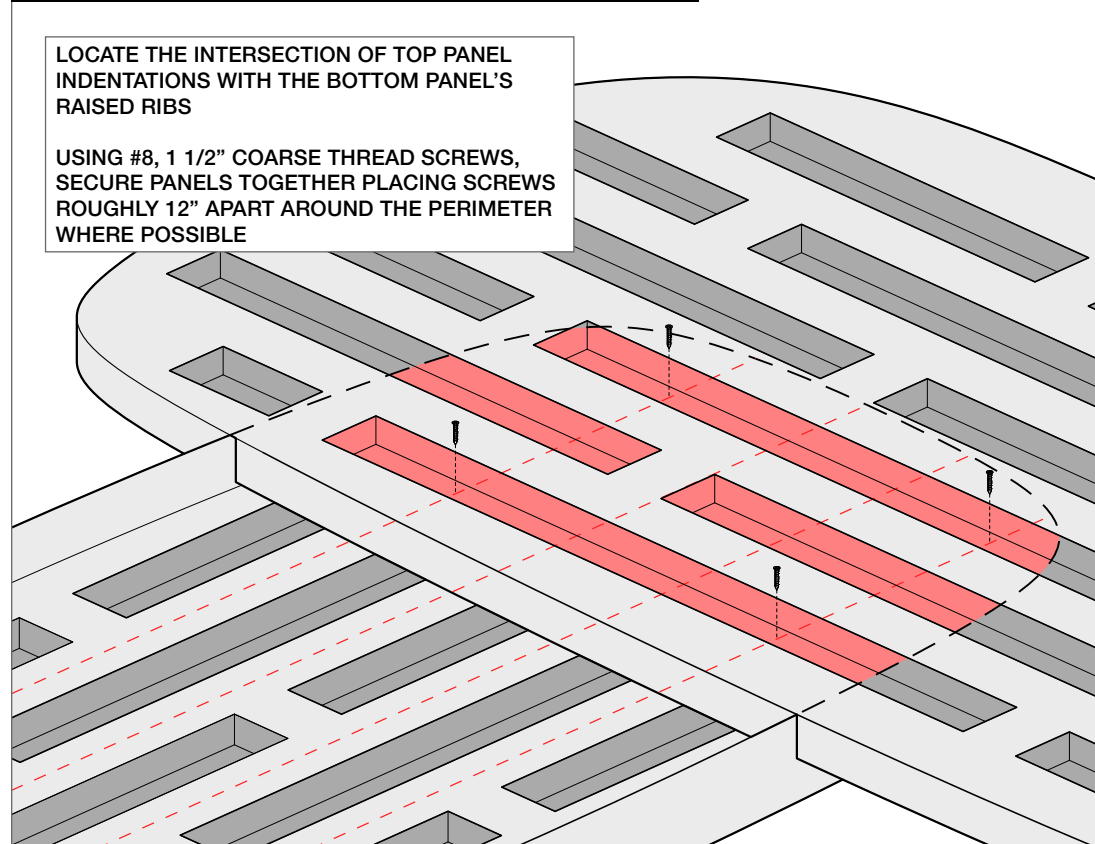

### 12 - USE 3" SCREWS AS REQUIRED

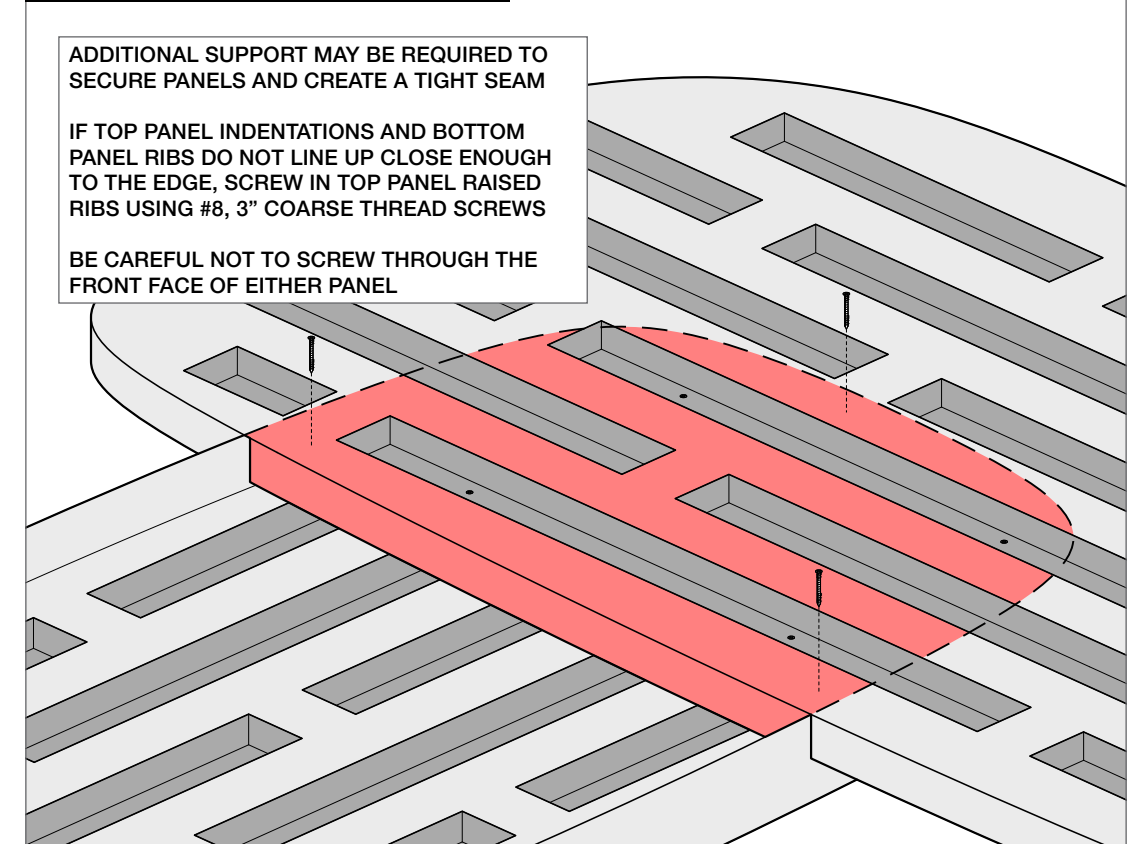

# Platter Trim Guide

**Field Modifications**

Platter is designed for quick installation, with modifications that can be easily completed in the field.

## Tools Required

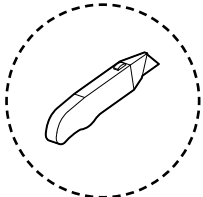

SHARP BLADE

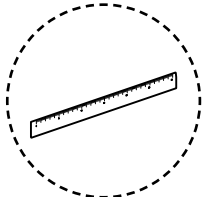

STRAIGHT EDGE

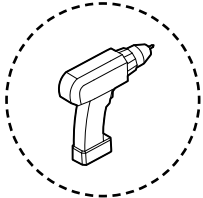

DRILL

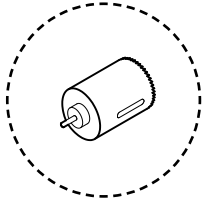

HOLE SAW

**1 - NO RIP OR CROSS CUTTING**

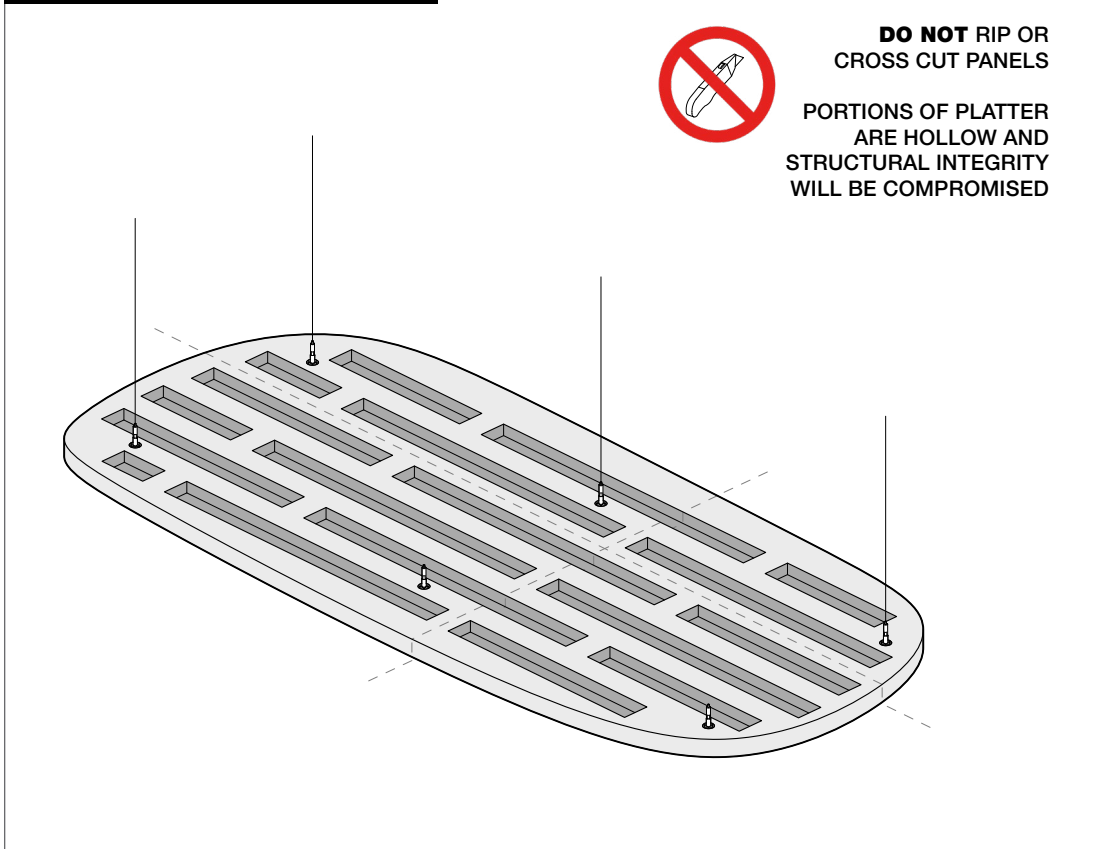

**2 - TRIM PLATTER AS REQUIRED**

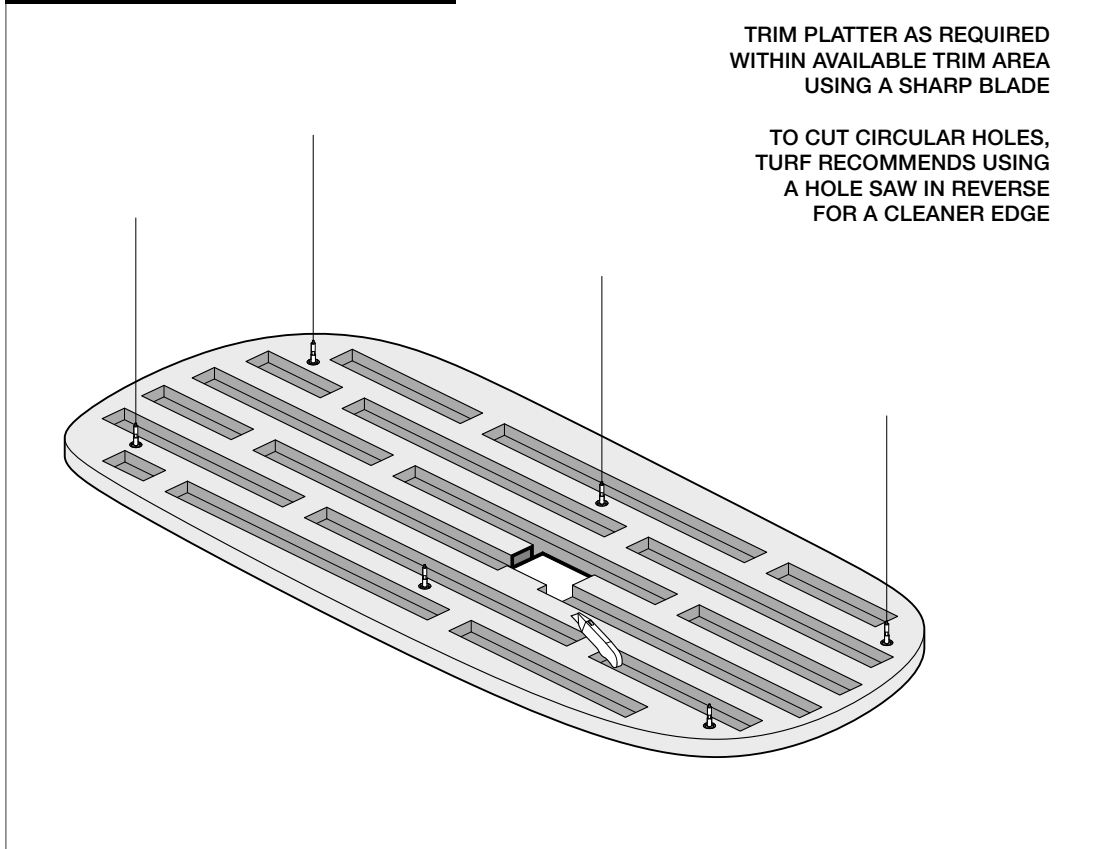

**3 - LARGE OPENINGS IN PANEL**

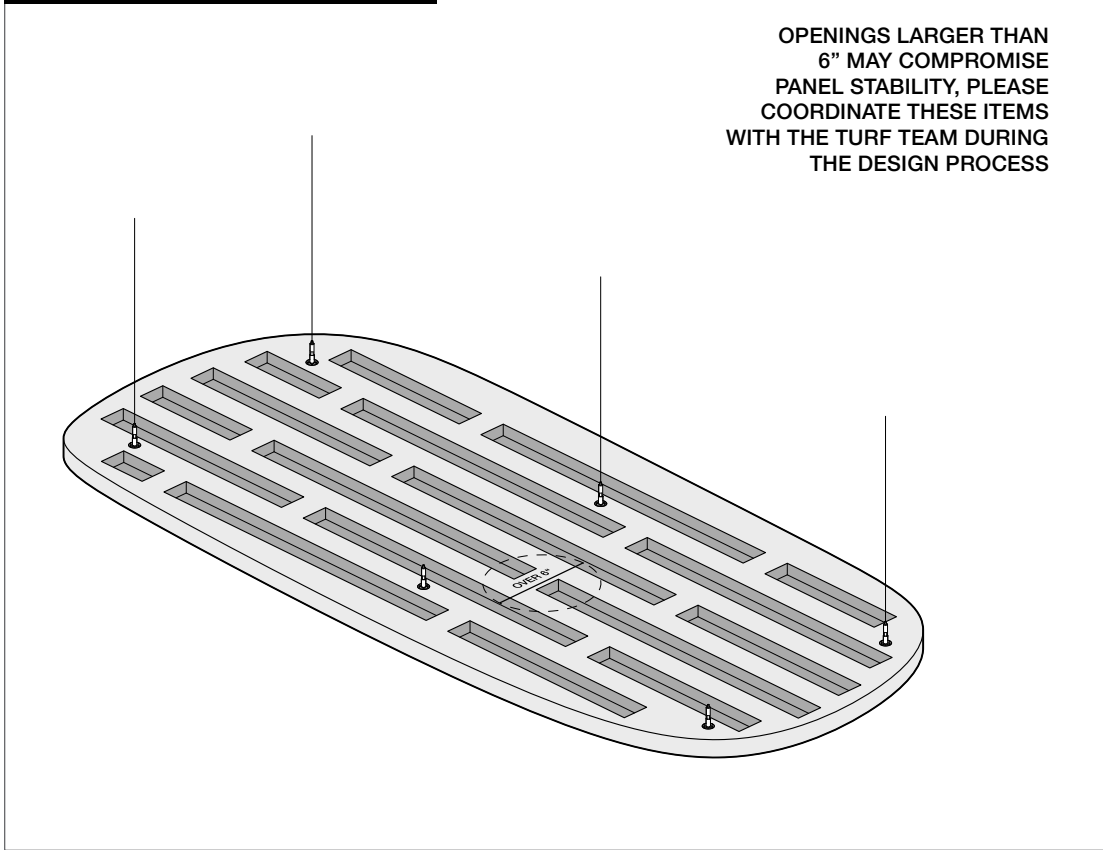

## Tech

Acoustics	ASTM C 423-17: Type J
Fire Rating	ASTM E-84 – Class A
VOC	ASTM D5116 Compliant

## Details

Lead Time	Check the Turf website for current lead times.
Warranty	Five (5) years
Maintenance	Vacuum to remove any particulate matter and air-borne debris or dust. Compressed air can be used to dust the material in difficult to reach areas for large assemblies. Contact us for more information relative to spot cleaning.
Weight	Turf products cannot support the weight of any other items in field.
Trademarks	Turf®, FeltLock™, GridLock™, T™ are trademarks of Turf Design, Inc. and/or its affiliates © 2025 Turf Design Inc. Printed in the United States of America

## Acoustic Rating

2" Depth	NRC = 1.15
4" Depth	NRC = 1.20
6" Depth	NRC = 1.30

Test results based on an array of three Platters suspended by cables.

## Certifications

# Declare.



Image by Imperfect\*

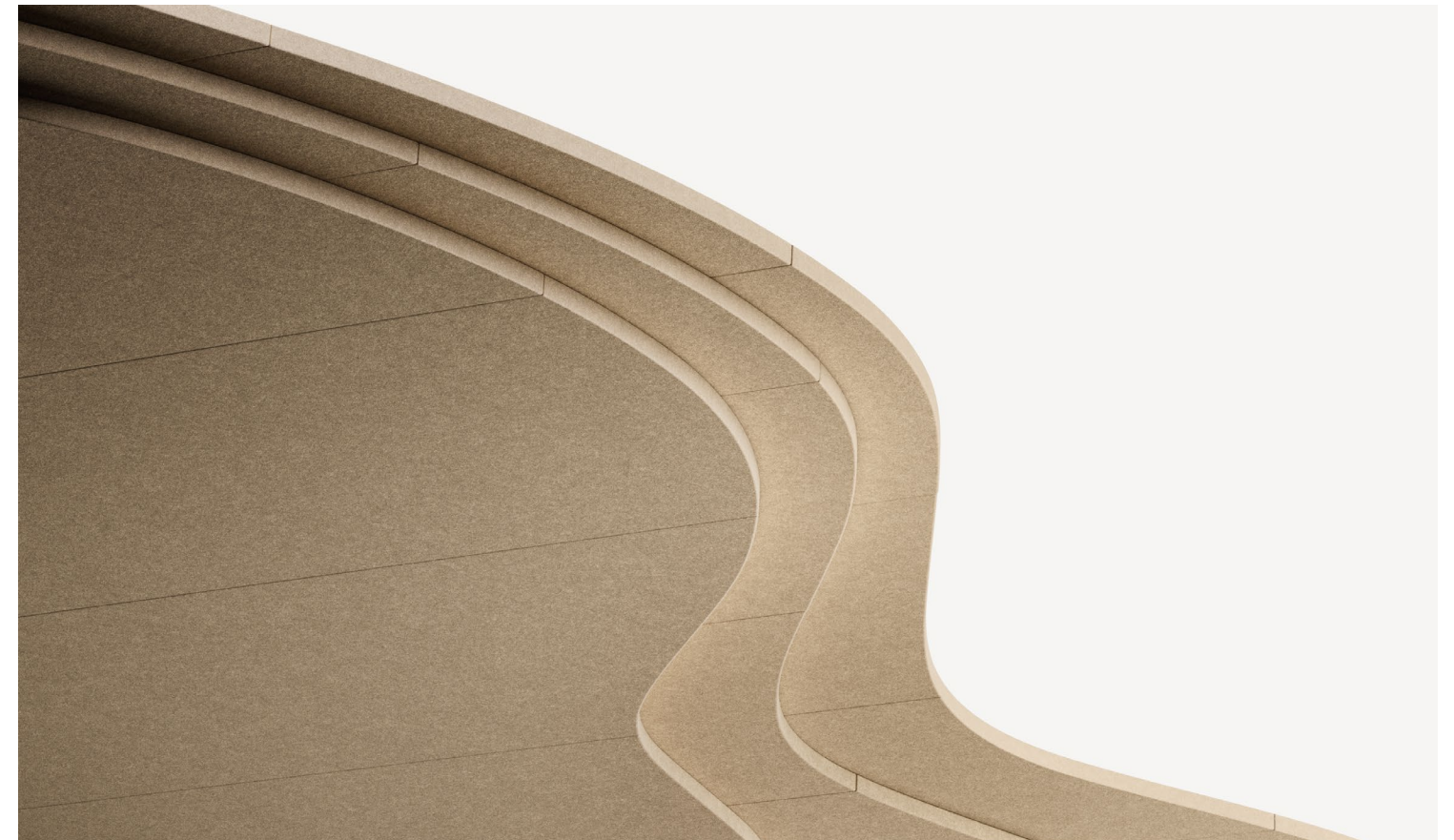

Image by CATK

# 9mm Colors

Introducing Hues, our new 9mm color palette designed for the senses.

The 9mm PET felt board is used as our primary construction material. Select one of our coordinating neutrals to blend in, or go for a contrasting element with one of our hues.

The process used to create PET felt often results in a heathered effect where multiple tones are present. Slight variations in color should be expected when using this sustainable material.

**Felt Thickness**  
9mm +/-0.5 mm

Monitors and printers vary. Please request a material sample to verify felt colors.



10 TOPO GREEN



12 GRASSHOPPER

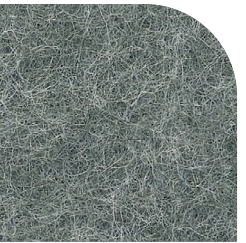

11 CELADON

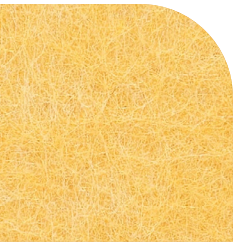

63 SAFFLOWER

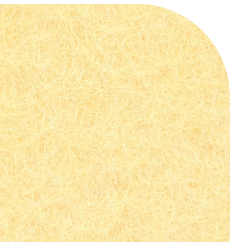

64 PLANTAIN

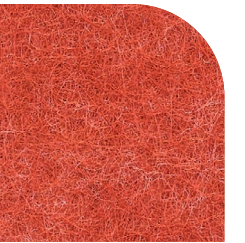

43 ORANGE CRUSH

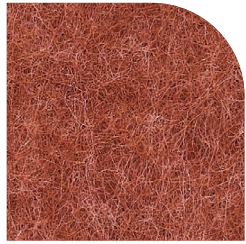

18 ULTISOL



17 BLUSH

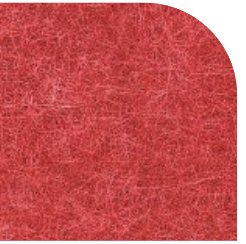

23 RED

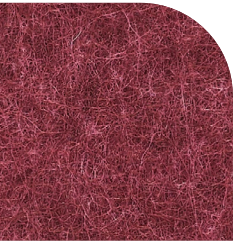

15 MERLOT

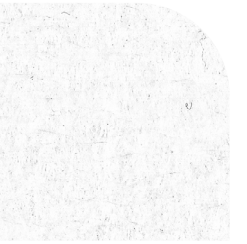

50 IVORY



33 LUMINARY



83 HOLLAND OATS



82 BARLEY



34 TONAL TAUPE



35 BARK

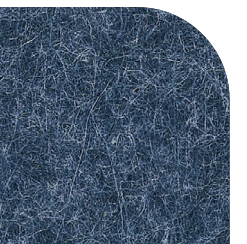

28 INDIGO

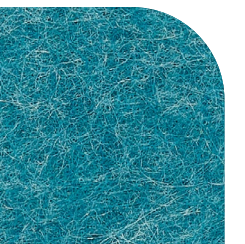

30 CYAN

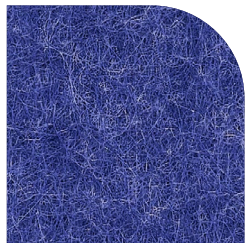

24 ROYAL BLUE

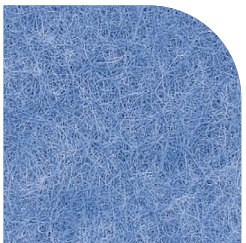

31 AZURE

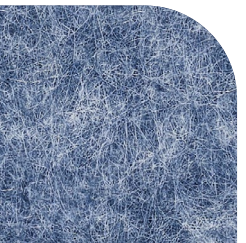

27 JEAN JACKET

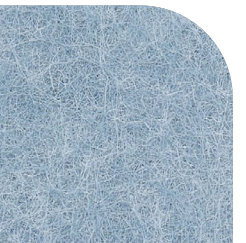

26 FADED DENIM



40 MAGENTA

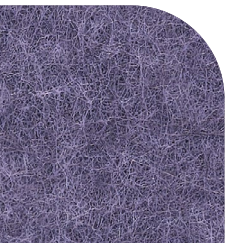

41 DRIED LAVENDER

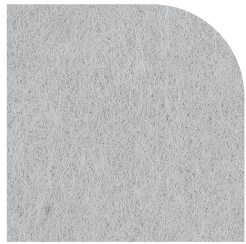

66 PEWTER



05 WHITE

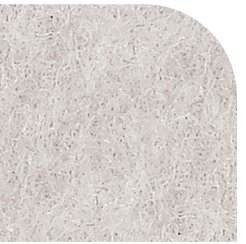

01 CREAM

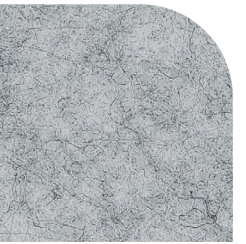

04 LIGHT GREY



98 STORM

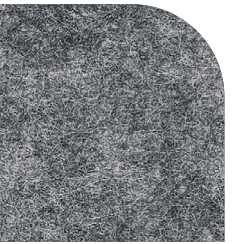

09 DAMASCUS

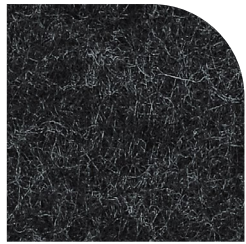

06 CHARCOAL



07 BLACK



# 9mm Wood Grains

Invite nature into your space with our wood-inspired grains. Digital printing on felt ensures a unique and realistic grain with virtually no repeats.

There is an additional product cost for Wood Grains.

Please note there is additional lead time for custom matching. Grain customization will incur additional costs beyond our standard 9mm options.

**Felt Thickness**  
9mm +/-0.5 mm

**Monitors and printers vary.**  
Please request a material sample to verify felt colors.



D01 WHITE ASH



D02 SILVER TEAK



D03 CLEAR MAPLE



D04 WASHED ASH



D05 MEDIUM OAK



D06 PLANKED OAK

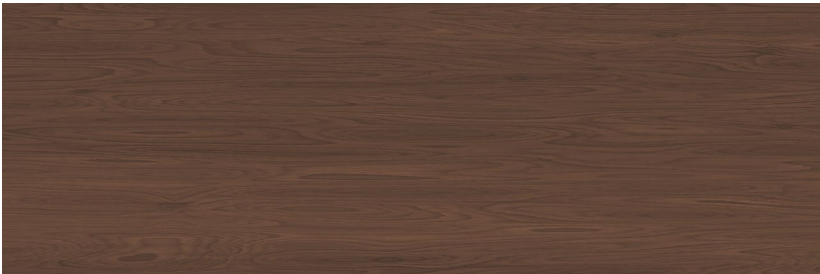

D07 DARK WALNUT



D08 BLACK PEAR

## 9mm Wood Textures

Designed for those who go against the grain. Our digitally printed Wood Textures are inspired by wood veneer cuts and are designed to work with all 32 of our Hues. Flat, Rift and Rotary each represent a unique aesthetic that gives you range in your designs.

There is an additional product cost for Wood Textures.

**Felt Thickness**  
9mm +/-0.5 mm

## Visualization

Our Wood Textures are available on all of our 32 Hues. Select a texture and felt color, and let Turf do the rest. Please visit the Turf website for more examples and visualizations.

[turf.design/colors](https://turf.design/colors)

07 Black is the only substrate color that uses white ink when printing the texture.

Monitors and printers vary. Please request a material sample to verify felt colors.

## How To Specify

### Select Color Number

Choose from the entire 9mm color line

W T 0 0

### Select Texture Name

Flat  
Rift  
Rotary

X X X X X X

WOOD TEXTURE

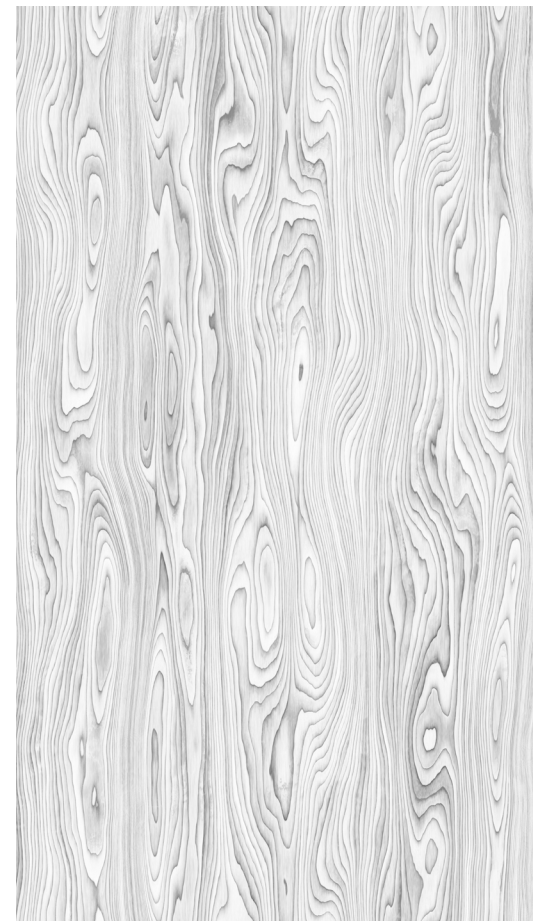

FLAT

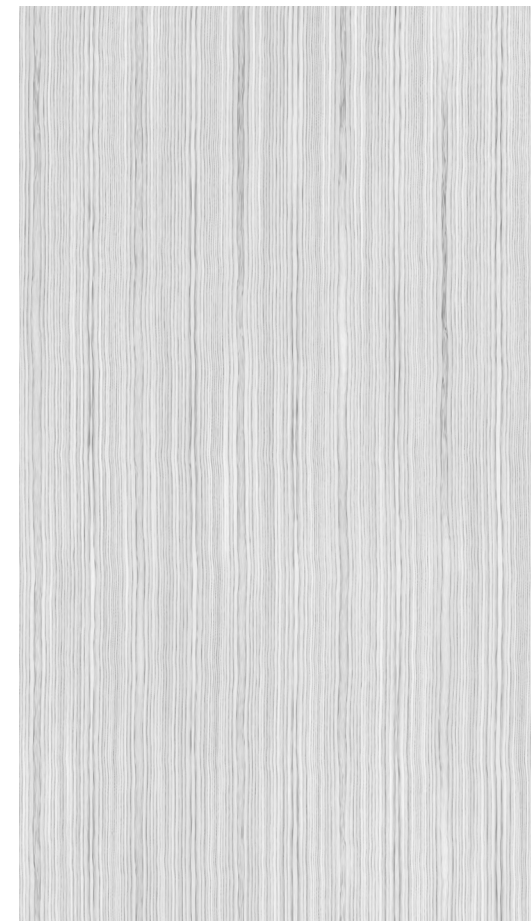

RIFT

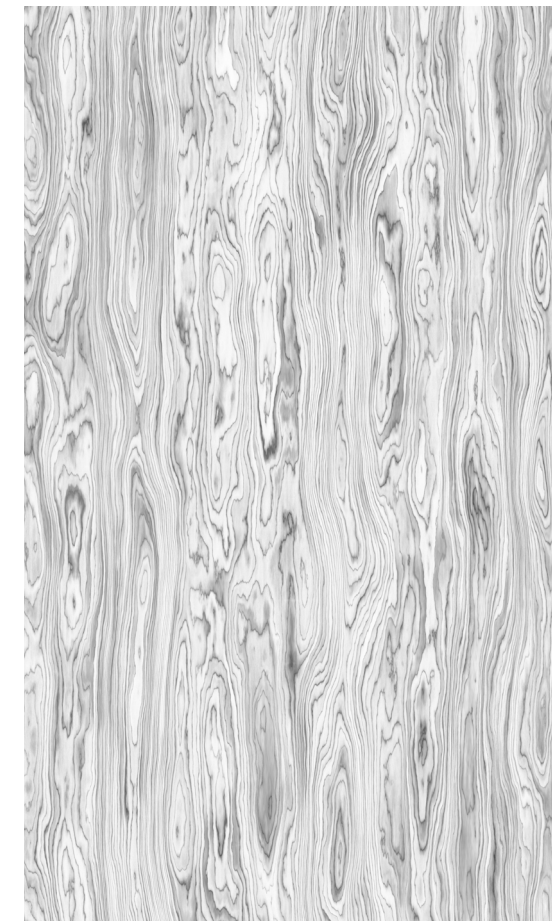

ROTARY

ALL COLORS AVAILABLE

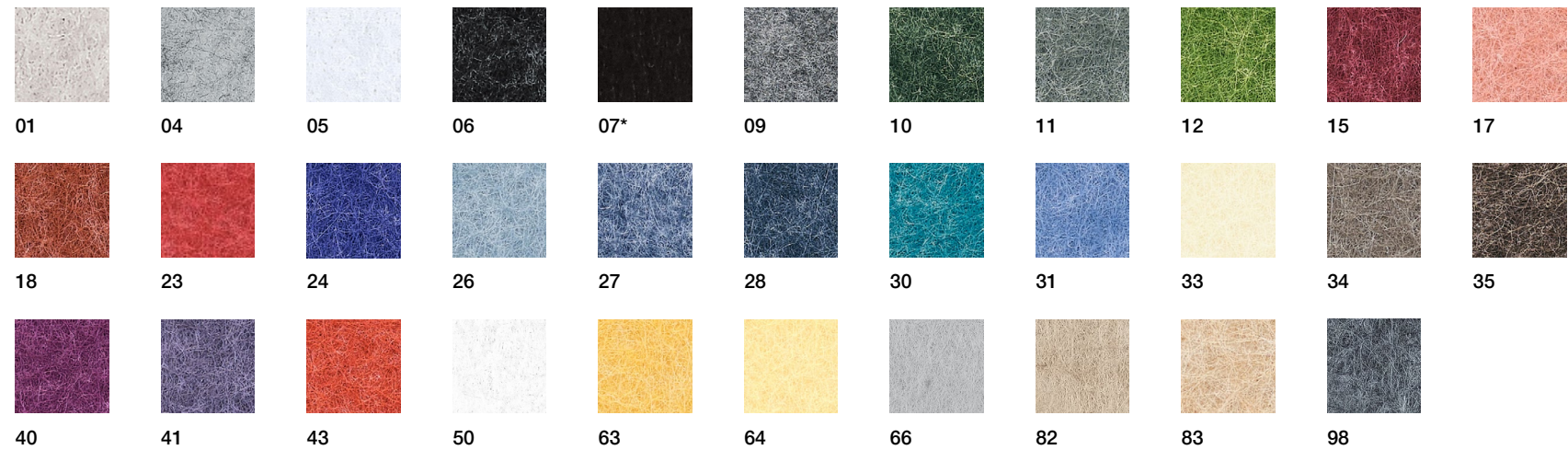

\* 07 Black is the only substrate color that uses white ink when printing the texture

## 9mm Stone Textures

Inspired by nature, designed for felt. Our digitally printed Stone Textures capture the character and nuance of stone on top of a curated color collection from our Hues palette with virtually no repeats. The three patterns in this family capture unique elements from the stones for which they are named.

There is an additional product cost for Stone Textures.

Turf has curated this collection to include only the best pattern and color combinations.

**Felt Thickness**  
9mm +/-0.5 mm

## Visualization

Our Stone Textures are available on a curated portion of the Hues collection. Select a texture and felt color, and let Turf do the rest. Please visit the Turf website for more examples and visualizations.

[turf.design/colors](https://turf.design/colors)

Monitors and printers vary. Please request a material sample to verify felt colors.

## How To Specify

### Select Color Number

Choose from the available color list

S T 0 0

### Select Texture Name

Travertine  
Granite  
Marble

X X X X X X X X X X X

STONE TEXTURE



TRAVERTINE



GRANITE



MARBLE

AVAILABLE COLORS

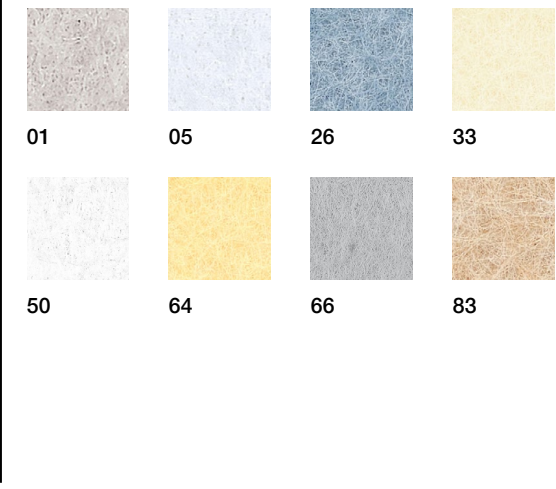
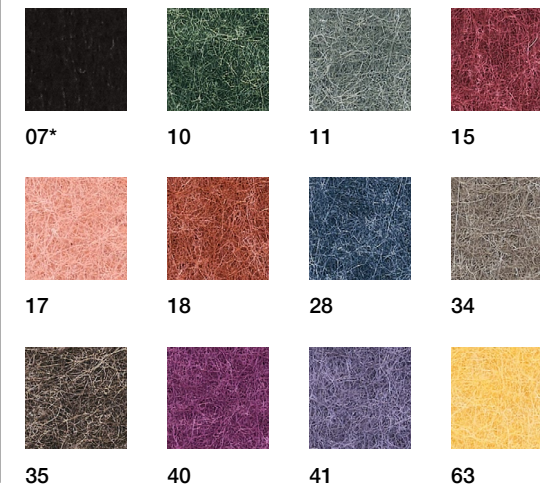
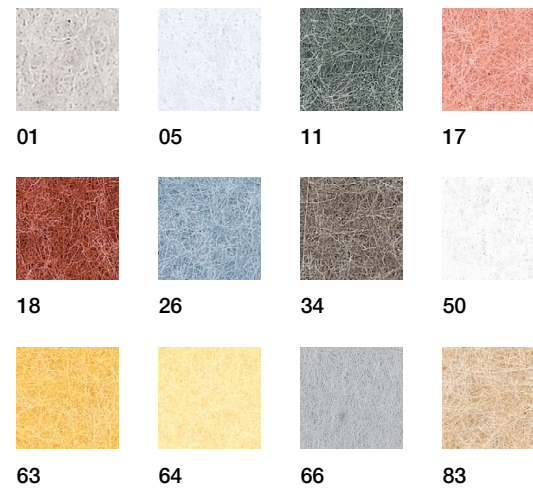

\* 07 Black is the only substrate color that uses white ink when printing the texture