

Marine Sentry™ RCD 3000 Rotating Control Device

SAFE, EFFICIENT CONTAINMENT AND DIVERSION OF DRILLING FLUIDS IN PRESSURE-CRITICAL APPLICATIONS

OVERVIEW

The Halliburton Marine Sentry™ rotating control device (RCD) provides a dual passive seal around the rotating drill string and tool joints to divert annulus returns during conventional or managed pressure drilling operations. The Marine Sentry RCD is designed for offshore jackup and fixed platform rigs and is mounted on the rig surface blowout preventer (BOP) stack.

The Marine Sentry RCD is equipped with a remote latching design, which assists in the safe and secure operation by the rig personnel. The system includes a hydraulic power unit (HPU) for on-demand oil lubrication of bearings and seals. An optional cooling system may be used for extreme pressures and high rpm applications.

Rated to 3,000 psi (20.7 MPa) static pressure and 3,000 psi (20.7 MPa) dynamic, the Marine Sentry RCD creates a pressure tight barrier between fluid returns and personnel on the rig floor, helping to safely contain annular fluids under pressure while drillpipe is rotating, and diverting fluids below the rig floor to the returns system without interrupting operations.

A range of available accessories includes test plug/casing stripping adapter, seal bore protector, and mechanical running and pulling tools for efficient deployment of bearing/seal element assembly and adapters through the riser tieback for latching/unlatching from the body.

FEATURES

- » API 16RCD monogrammed
- » Static and dynamic pressure ratings of 3,000 psi (20.7 MPa)
- » Patented remote latching system can enable operator to safely and securely latch or unlatch bearing/seal element and accessory equipment without manual operation by personnel below rig floor
- » External lubrication system for extended run times with proven track history and no scheduled time limits
- » Patented pump out feature eliminates the need to run a separate tool for retrieving the bearing
- » Optional cooling system for maximum dynamic rating envelope
- » Certification to CE / ATEX / NORSOK and DNV 2.7-1 / 2.7-3 (optional)

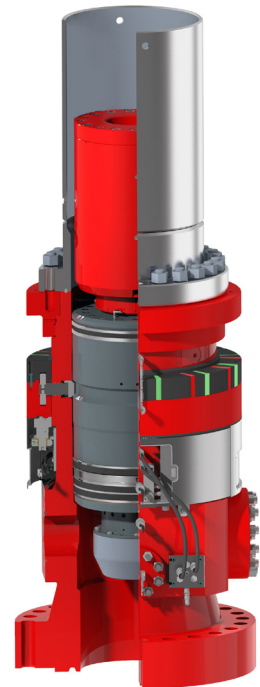

BENEFITS

- » Improves safety and efficiency in pressure-critical applications
- » Maintains tight control of drilling fluid to enhance HSE
- » Seamlessly integrates with managed pressure drilling systems to reduce nonproductive time, reduce cost through rate of penetration improvement, and casing program optimization

APPLICATIONS

- » Managed pressure drilling, underbalanced drilling, air drilling, continuous circulating system, mud cap drilling, managed pressure cementing
- » Shallow gas and abnormally pressured formations
- » Casing drilling
- » Offshore fixed platform or jackup rigs
- » Extended-reach horizontal and ultra-deep vertical wells
- » Kick control in conventional drilling

Equipment Specifications

Physical	
ID, Bearing Assembly, in. (mm)	9.055 (230)
OD, Bearing Assembly, in. (mm)	21-1/8 (537)
Bearing Weight, Approx., lb. (kg)	2,500 (1,134)
Bearing Length, in. (mm)	45-1/4 (1,149)
Body Weight, lb. (kg)	8,620 (3,910)
Body Height, in. (mm)	64 (1,626)
Ratings	
Maximum Static Pressure, psi (MPa)	3,000 (20.7)
Maximum Dynamic Rating, psi (MPa)	3,000 (20.7)
Maximum Rotary Speed	200 rpm
Connections	
Bottom Flange	API 18-3/4 5K, 10K
Bottom Flange Diameter, in. (mm)	18-3/4 in. 5K: 35-5/8 (905) 18-3/4 in. 10K: 40-15/16 (1,040)
Top Flange	API 21-1/4 in 2K (studded)
Dual Side Outlet	API 7-1/16 in. 5M (studded)
Dimensions, in. (mm)	
A	97-1/2 (2,477)
B	63-3/4 (1,619)
C	18 (457)
D	18-3/4 (476)
E	21-1/2 (540)
F	9-1/16 (230)
G	21-1/8 (537)
Power Requirements	
HPU	380/480 VAC 50/60 Hz
Workshop	380/480 VAC 50/60 Hz
HMI	110/220 VAC 50/60 Hz

**Marine Sentry™ RCD 3000
Pressure / RPM Operating Envelope**

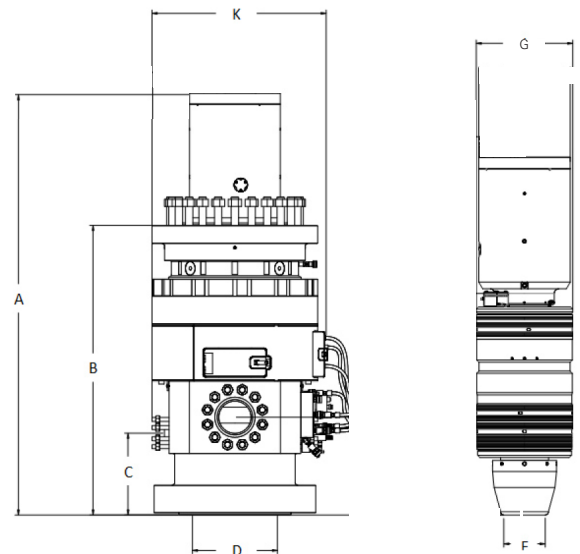
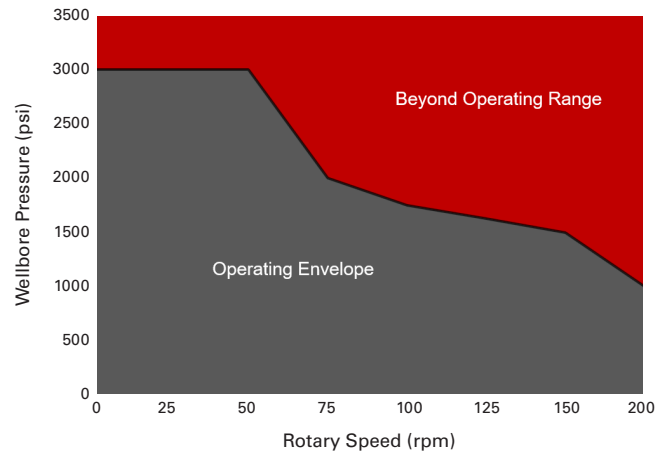

For more information, contact your local Halliburton representative or visit us on the web at www.halliburton.com

Sales of Halliburton products and services will be in accord solely with the terms and conditions contained in the contract between Halliburton and the customer that is applicable to the sale.

H011838 2/22 © 2022 Halliburton. All Rights Reserved.