

Exploded view of AIRP 300, 77 mm
Updated 21.10.2024

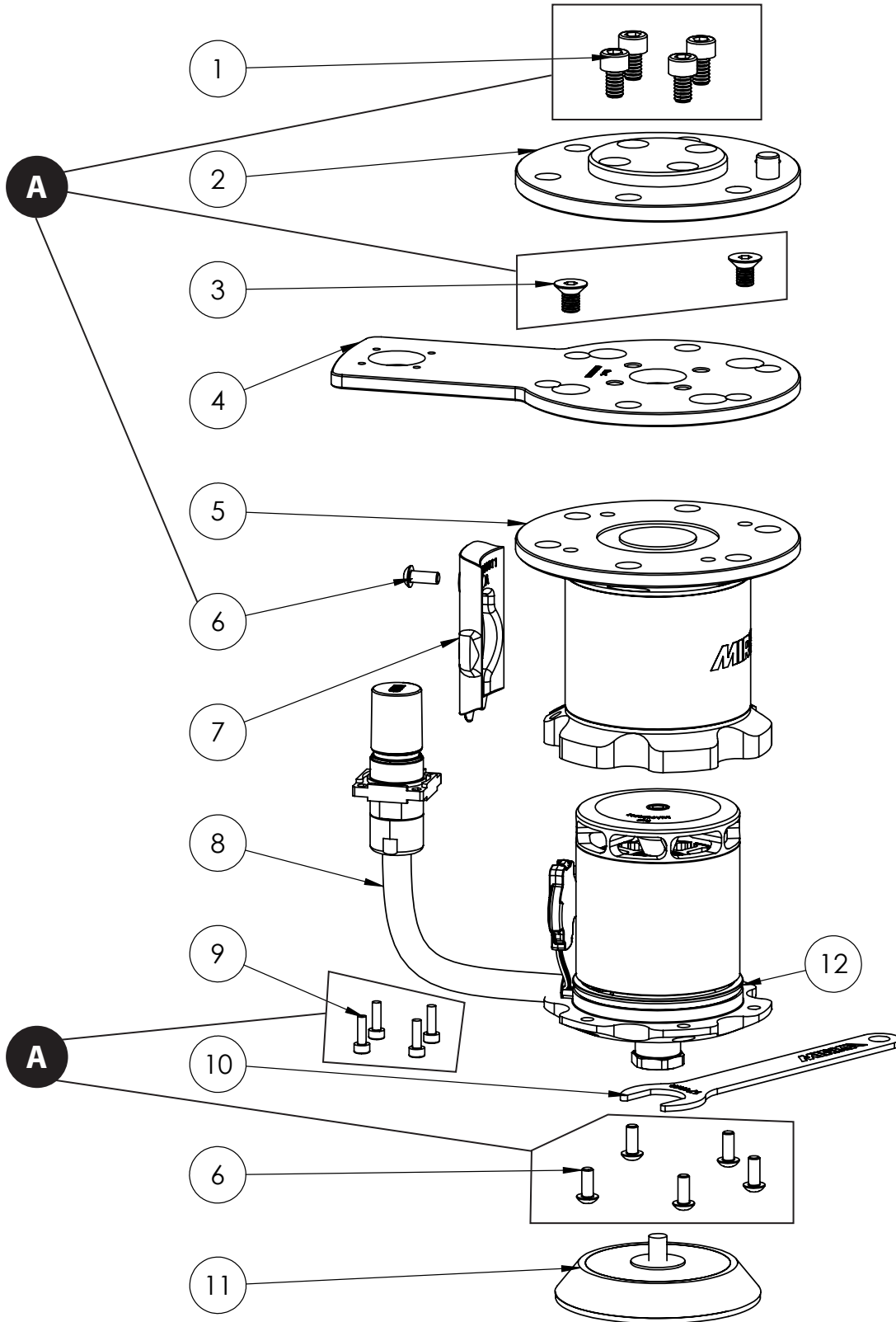

AIRP 300, 77mm Spare Part kits (48V)

Electrical tool must be serviced by a qualified repair person and in accordance with national requirements.

Note! Repairs performed by non-authorized repairer will breach the Mirka warranty.

Mirka Code	Item	Description	Kit	Qty	Tightening Torque
MIA6520211		Screw kit	A		
	1	Screw M6x10 DIN 912 8.8 ZN		4	10 Nm/7,4 ft-lb
	3	Screw M6x10 DIN 7991 10.9		2	8 Nm/5,9 ft-lb
	6	Screw M4x10 TX ISO 7380		6	
	9	Screw M3x10 TX ISO 14579 8.8 ZN		4	1,8 Nm/1,3 ft-lb

AIRP 300, 77mm Spare Parts (48V)

Mirka Code	Item	Description	Kit	Qty	Tightening Torque
	1	Screw M6x10 DIN 912 8.8 ZN	A	4	10 Nm/7,4 ft-lb
MIA6510111	2	Flange ISO 9409-1-80-6-M8		1	
	3	Screw M6x10 DIN 7991 10.9	A	2	8 Nm/5,9 ft-lb
MIA3010411	4	Connector Plate		1	
MIA3010611	5	Housing*		1	
	6	Screw M4x10 TX ISO 7380	A	6	
MIA3010811	7	Id Tag Holder		1	0,8 Nm/0,6 ft-lb
MIA3020911	8	Motor*		1	2,4 Nm/1,8 ft-lb
	9	Screw M3x10 TX ISO 14579 8.8 ZN	A	4	1,8 Nm/1,3 ft-lb
8993008013	10	Pad Wrench 17mm		1	
8294791311	11	Backing Pad 77mm		1	
MIA3011211	12	O-Ring 55x2.0 mm		1	

* Spare parts only available to authorized repairers.