

GENERAL ARRANGEMENT DETAILS	
PUMP INFORMATION	
PUMP MODEL	REVOLUTION - TWIN WING R0300X/17
INLET CONNECTION	1.5" TRI-CLAMP (3A)
OUTLET CONNECTION	1.5" TRI-CLAMP (3A)
SPECIAL FEATURES	NONE

THIS IS NOT A CERTIFIED DRAWING, USE FOR GENERAL INSTALLATION ONLY

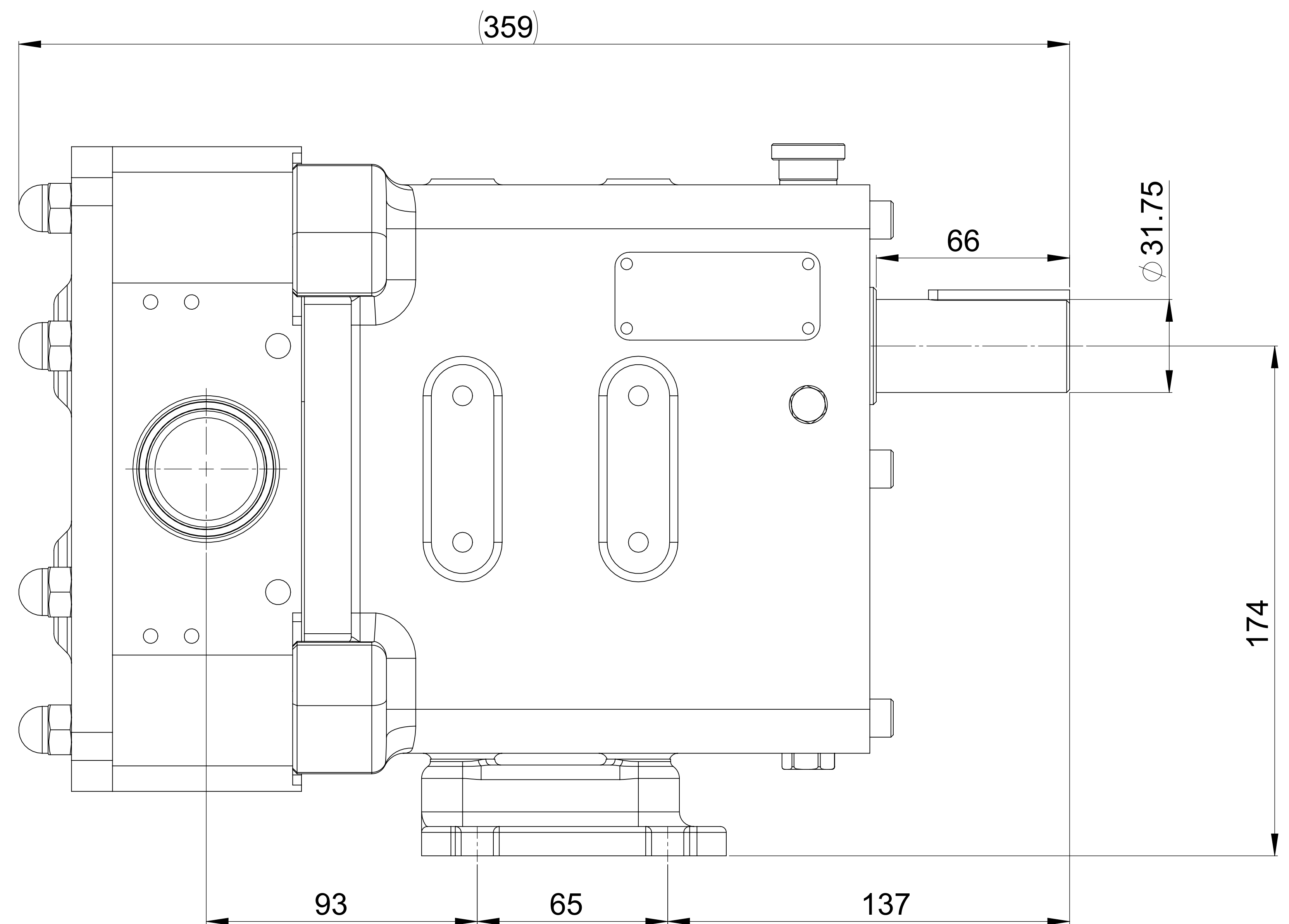
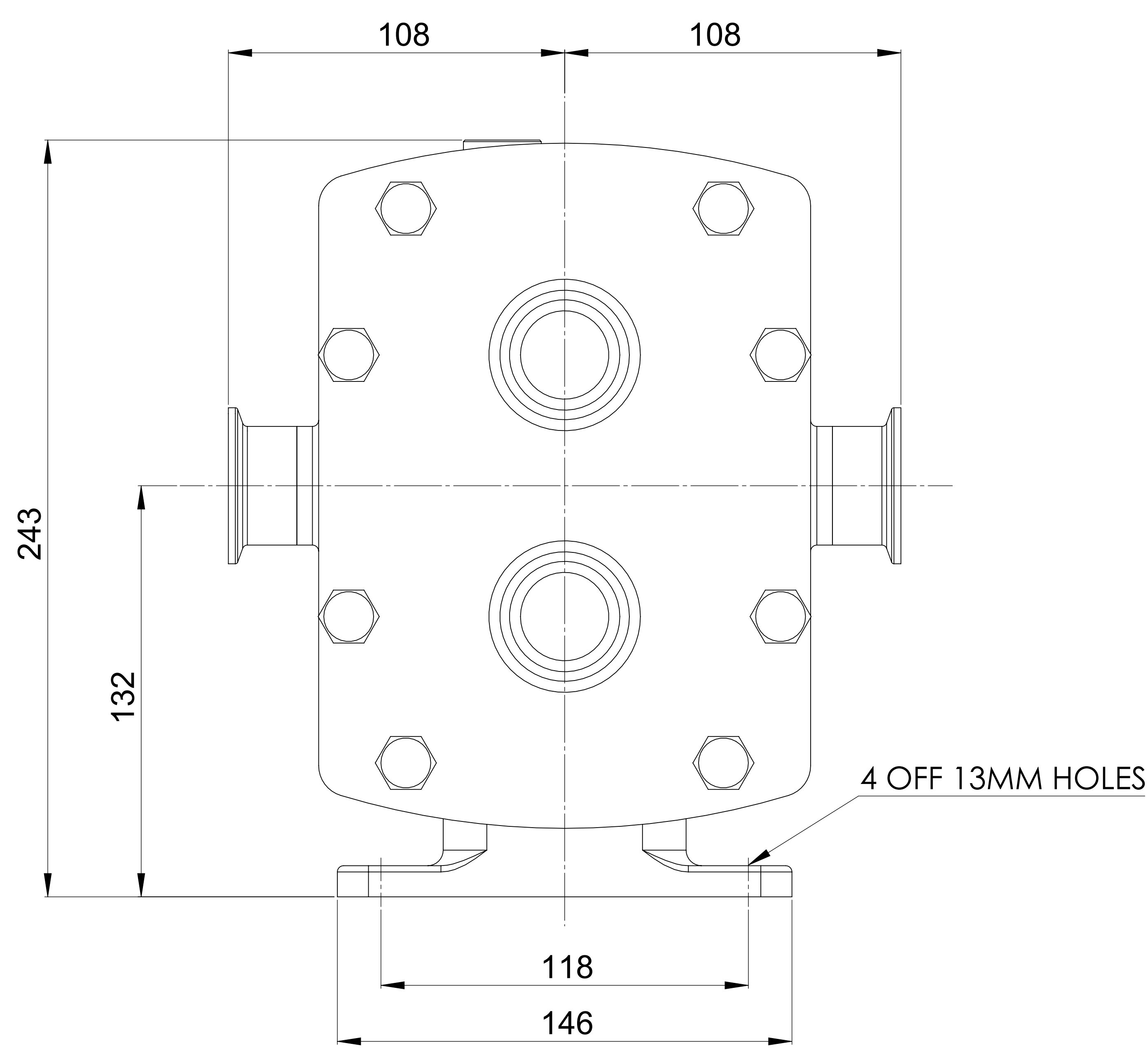
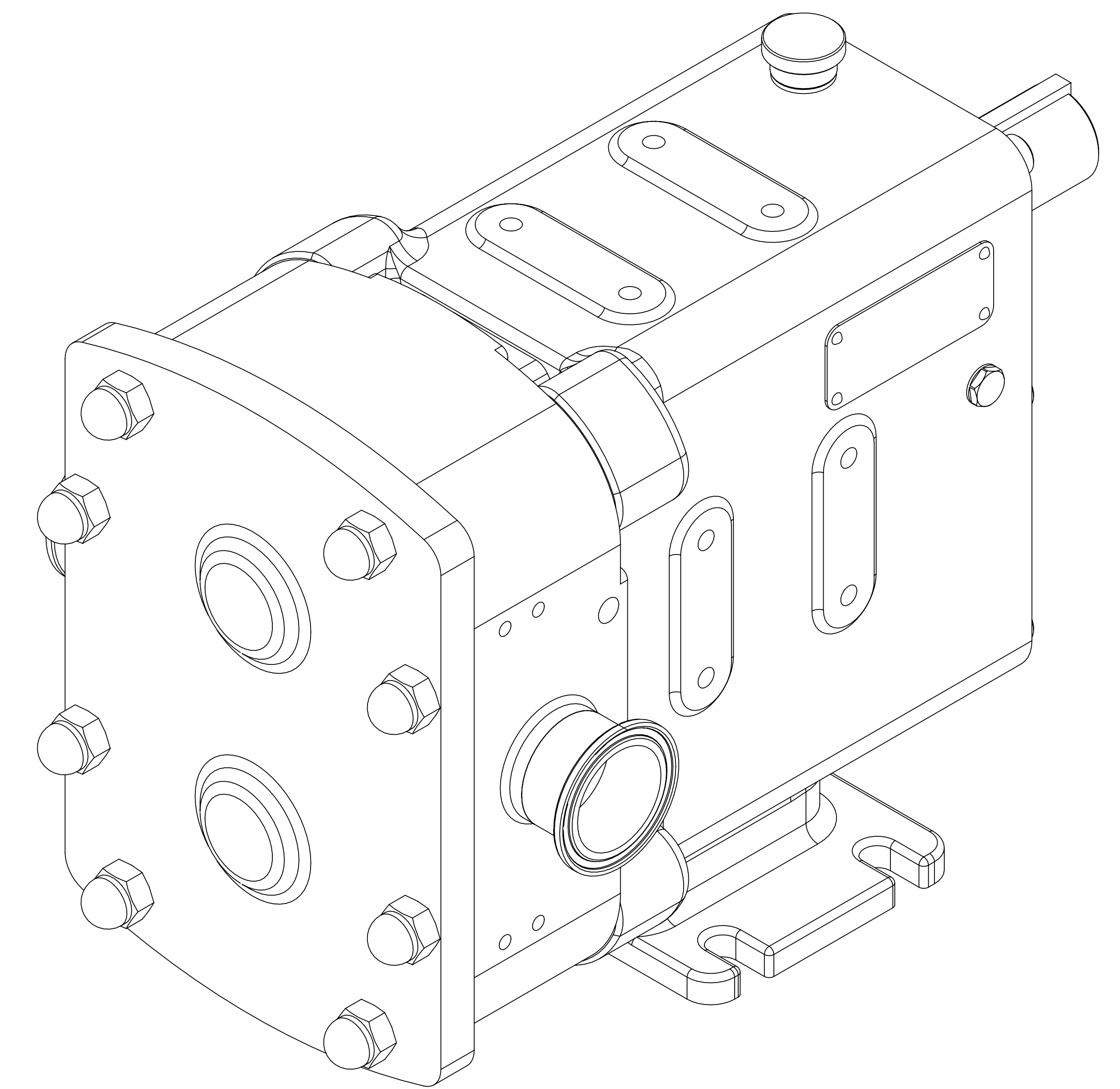

ISSUED	A	13/04/2017
AMENDMENT	ISSUE	DATE

 HIGHFIELD INDUSTRIAL ESTATE, EASTBOURNE, EAST SUSSEX, BN23 6PT TEL: (+44) 1323 509211	COPYRIGHT: THIS DRAWING IS THE SOLE PROPERTY OF WRIGHT FLOW TECHNOLOGIES LTD. IT MUST NOT BE COPIED OR USED IN PART OR FULL WITHOUT PRIOR WRITTEN CONSENT.	UNLESS OTHERWISE STATED: ALL DIMENSIONS ± 2.50 ANGLES ±2.0° DO NOT SCALE THIS DRAWING REMOVE BURRS AND SHARP EDGES DIMENSIONS IN MILLIMETRES IF IN DOUBT ASK	PROJECTION	DRAWN	CHECKED	TITLE:
				KCB	IPJB	DRG. NO:
						GENERAL ARRANGEMENT
						GA3617