

# SPUR GEAR PRODUCT LINE: CAST & DUCTILE IRON SEALLESS MAG DRIVE PUMPS

SG-805 Series™, SGN-805 Series™, SG-807 Series™, SGN-807 Series™

Section	1453
Page	1453.1
Issue	H

## TABLE OF CONTENTS

Features & Benefits .....	2
Model Number Key .....	2
Standard Materials of Construction .....	2
Typical Applications.....	2
Specifications .....	3
Mounting Options.....	4
Dimensions – SG-805 Series™ & SGN-805 Series™ – MD-A (B Drive – Footed Bracket) .....	5
Dimensions – SG-807 Series™ & SGN-807 Series™ – MD-A (B Drive – Footed Bracket) .....	6
Dimensions – SG-807 Series™ & SGN-807 Series™ – MD-B (B Drive – Footed Bracket).....	7
Dimensions – SG-805 Series™ & SGN-805 Series™ – MD-A NEMA C (M Drive – Footless Bracket).....	8
Dimensions – SG-807 Series™ & SGN-807 Series™ – MD-A NEMA C (M Drive – Footless Bracket).....	9
Dimensions – SG-807 Series™ & SGN-807 Series™ – MD-A NEMA C (M Drive – Footed Bracket) .....	10
Dimensions – SG-807 Series™ & SGN-807 Series™ – MD-B NEMA C (M Drive – Footed Bracket) .....	11
NPSH Required .....	12
Selecting the Correct Viking Mag Drive® Coupling.....	12
Example .....	12

## SERIES DESCRIPTION

Where shaft seal leakage is not allowable, for liquids that are hard to seal, or where seal maintenance is difficult, Viking Mag Drive® sealless SG pumps are the solution. In this type of pump, a canister hermetically seals the liquid within the pump. Inner magnets are connected to the pump drive shaft inside the canister, and an outer magnet assembly rotates outside of the canister, driven by a motor or other drive, so that magnetic forces pass through the canister to the inner magnets and cause the drive shaft to rotate. This eliminates traditional dynamic shaft seals, and problems associated with them (wear, leakage, air infiltration).

A hollow drive shaft allows some liquid to flow by means of pressure differential from the high pressure side of the pump through the shaft, into the canister and back to the low pressure side of the pump. This provides magnet cooling and prevents product stagnation.

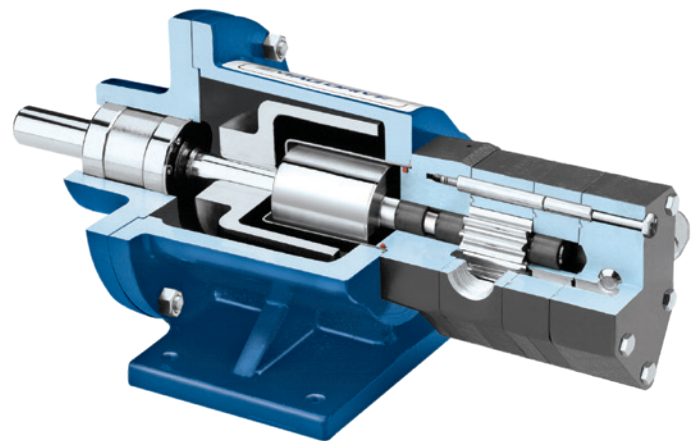

## RELATED PRODUCTS

Cast Iron Pumps: Catalog Section 1451

## OPERATING RANGE

SERIES	NOMINAL FLOW		MAXIMUM PRESSURE*		TEMPERATURE RANGE		VISCOSITY RANGE	
	GPM	m <sup>3</sup> /h	PSI	Bar	°F	°C	SSU	cSt
SG-805 Series™ & SGN-805 Series™	0.7 - 11.2	.16 - 2.54	500	34	-40 to +450	-40 to +230	28 to 250,000	1 to 55,000
SG-807 Series™ & SGN-807 Series™	4 - 32	.91 - 7.27	500	34	-40 to +450	-40 to +230	28 to 250,000	1 to 55,000

\* to 500 PSI (34 Bar) Continuous, to 2,500 PSI (170 Bar) Intermittent Pressure

Section	1453
Page	1453.2
Issue	H

## SPUR GEAR PRODUCT LINE: CAST & DUCTILE IRON SEALLESS MAG DRIVE PUMPS

SG-805 Series™, SGN-805 Series™, SG-807 Series™, SGN-807 Series™

### FEATURES & BENEFITS

- Needle bearings provide high pressure capabilities, sleeve bearing options available
- Close-coupled motor mount or foot bracket options to match space or motor requirements

### TYPICAL APPLICATIONS

- Fuels and Additives
- Polyurethane Meter / Mix
- Adhesive & Sealant Dispensing
- Pipeline Sampling
- Chemical Metering
- Heat Transfer Oils

### MODEL NUMBER KEY

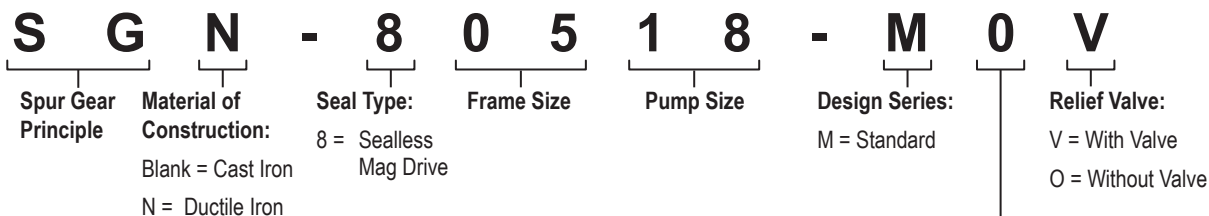

**NOTE:** Direction of rotation: clockwise is standard, counter-clockwise is optional. Bi-rotational is not available as Mag Drive.

**NOTE:** Mag Drive pumps are connected to a magnetic coupling, which is specified separately. Coupling options are MD-A and MD-B. Specify NEMA or IEC face mount for close-coupled or bearing carrier for long-coupled.

**Shaft Rotation:**  
(Viewed from Shaft End)  
0 = Clockwise (standard)  
1 = Counter-Clockwise (optional)

### STANDARD MATERIALS OF CONSTRUCTION

Component	SG-805, -807	SGN-805, -807	Options
Casing, Bracket, Head, Separation Plate	Cast Iron, ASTM A823	Ductile Iron, ASTM A536	Surface Hardening (Vitek)
Relief Valve Body	Cast Iron, ASTM A823	Ductile Iron, ASTM A536	—
Relief Valve Poppet	Hardened Steel	Hardened Steel	—
Relief Valve Spring	Steel, ASTM A229	Steel, ASTM A229	—
Gears	Hardened Steel	Hardened Steel	—
Shafts	Case-Hardened Steel, ASTM A322	Case-Hardened Steel, ASTM A322	Nitralloy
Anti-Friction Needle Bearings	—	—	Bearing Steel
Sleeve Bearings	Carbon Graphite	Carbon Graphite	Silicon Carbide
O-Rings	Buna-N	Buna-N	Neoprene, PTFE, FFKM, FKM
Canister	316L Stainless Steel	316L Stainless Steel	Alloy C
Magnetic Coupling Bracket (not wetted)	④ Cast Iron, ASTM A823	④ Cast Iron, ASTM A823	—
Magnets (outer magnets nickel plated, inner magnets sealed in SS canister)	① Neodymium Iron Boron	① Neodymium Iron Boron	② Samarium Cobalt

① Maximum temperature 225°F / 107°C.

② Maximum temperature 500°F / 260°C.

③ Casing is Ductile Iron ASTM A536 Grade 65-45-12 (Vitek Hardened).

④ Magnetic coupling brackets are aluminum for 182/184TC frame motors.

# SPUR GEAR PRODUCT LINE: CAST & DUCTILE IRON SEALLESS MAG DRIVE PUMPS

SG-805 Series™, SGN-805 Series™, SG-807 Series™, SGN-807 Series™

Section	1453
Page	1453.3
Issue	H

## SPECIFICATIONS

④ Model Number	Port Size  Inches	Nominal Capacity at 50 Hz Motor Speeds (1450 RPM)		Nominal Capacity at 60 Hz Motor Speeds (1750 RPM)		Maximum Continuous Pressure		Approximate Shipping Weight (Pump with Valve, but Less Power)		② Magnetic Coupling			① Maximum Working Pressure		Approximate Shipping Weight (Coupling Only, Ready to Accept but Less Power)	
		GPM	m³/h	GPM	m³/h	PSIG	BAR	Lbs.	Kg.	Series	Torque		PSIG	BAR	Lbs.	Kg.
											Ft-Lbs	Nm				
SG-80518	½ ③	0.57	0.13	0.7	0.16	500	34	6	2.7	MD-A	4 9	5.4 12.2	1000	69	31	14
SG-80525	½ ③	0.84	0.19	1	0.23	500	34	6	2.7							
SG-80535	½ ③	1.14	0.26	1.4	0.32	500	34	6	2.7							
SG-80550	½ ③	1.67	0.38	2	0.45	500	34	7	3.2							
SG-80570	½ ③	2.33	0.53	2.8	0.64	500	34	7	3.2							
SG-80510	½ ③	3.30	0.75	4	0.91	500	34	8	3.6							
SG-80514	¾ ③	4.62	1.05	5.6	1.27	500	34	9	4.1							
SG-80519	¾ ③	6.30	1.43	7.6	1.73	200	14	10	4.5							
SG-80528	¾ ③	9.29	2.11	11.2	2.54	100	7	11	5.0							
SG-80741	1 ③	3.30	0.75	4	0.91	500	34	15	6.8	MD-A	4 9	5.4 12.2	1000	69	31	14
SG-80758	1 ③	4.62	1.05	5.6	1.27	500	34	17	7.7							
SG-80782	1 ③	6.65	1.51	8	1.82	500	34	18	8.2							
SG-80711	1 ③	9.29	2.11	11.2	2.54	500	34	19	8.6							
SG-80716	1 ③	13	3.01	16	3.63	500	34	20	9.1							
SG-80722	1½ x 1¼ ③	18	4.14	22	5.00	500	34	41	18.6	MD-B	40	54.0	500	28	71	32
SG-80732	1½ x 1¼ ③	27	6.02	32	7.27	500	34	43	19.5							

**NOTE:** Maximum temperature (standard construction) 225°F, 107°C. Higher temperatures can be handled with Samarium Cobalt magnets and optional O-ring elastomers. For torque and temperature limits, refer to "Table 1" on page 1453.12, "Table 2" on page 1453.12 and "Table 3" on page 1453.12 .

- ① Optional high pressure canisters available. Consult factory.
- ② Refer to "Selecting the Correct Viking Mag Drive® Coupling" on page 1453.12
- ③ NPT standard. Consult factory for other port size or type options such as BSP, SAE O-Ring or other.
- ④ Cast Iron models shown; also available in ductile iron (SGN)

Section	1453
Page	1453.4
Issue	H

## SPUR GEAR PRODUCT LINE: CAST & DUCTILE IRON SEALLESS MAG DRIVE PUMPS

SG-805 Series™, SGN-805 Series™, SG-807 Series™, SGN-807 Series™

### MOUNTING OPTIONS



#### Motor Mounted Units (M Drive)

Pump and motor mounted to a flange mounting bracket with magnetic coupling.

This mounting arrangement eliminates the need for on-site coupling alignment that is normally required with a base mounted unit.

Series SG-805 & -807 pumps may be close coupled to NEMA-C faced motors and SG-810 & -814 to both NEMA-C and IEC B5 flanged motors to provide an easily-assembled, compact pumping unit. This mounting arrangement eliminates the need for on-site coupling alignment that is normally required for a base-mounted unit

**SG-805 Series™, SGN-805 Series™,  
SG-807 Series™, SGN-807 Series™**



#### Foot Bracket Mounted Pumps (B Drive)

Pump is mounted to a foot bracket.

Series SG-8 pumps are available with a bearing carrier mounted to the magnetic coupling to provide an external drive shaft for long-coupling to a reducer, gear motor or other drive. The 3.5" shaft height on MD-A couplings matches the shaft height on Viking "A" series reducers, as well as NEMA 56, 143 and 145 T motors. The 6.25" shaft height on MD-B couplings matches shaft height on 254/256 T motors.

**SG-805 Series™, SGN-805 Series™,  
SG-807 Series™, SGN-807 Series™**

# SPUR GEAR PRODUCT LINE: CAST & DUCTILE IRON SEALLESS MAG DRIVE PUMPS

SG-805 Series™, SGN-805 Series™, SG-807 Series™, SGN-807 Series™

Section	1453
Page	1453.5
Issue	H

## DIMENSIONS – SG-805 SERIES™ & SGN-805 SERIES™ – MD-A (B DRIVE – FOOTED BRACKET)

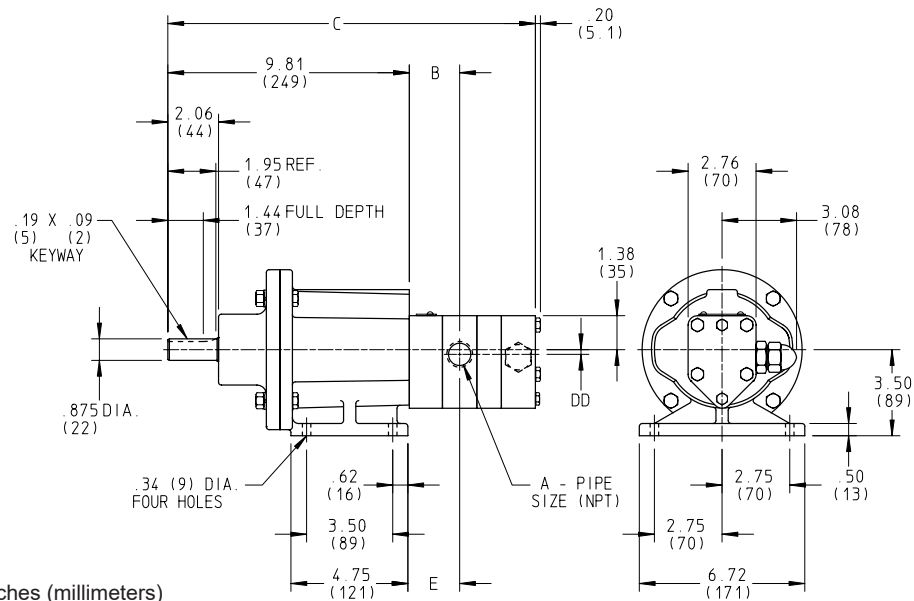

NOTE: Dimensions in inches (millimeters)

Model Number	A (in)		WITH R/V			LESS R/V			DD
			B	C	E	B	C	E	
SG-80518MD-A SGN-80518MD-A	1/2	in	2.02	13.71	2.08	2.21	12.71	2.27	0.31
		mm	51	348	53	56	323	58	8
SG-80525MD-A SGN-80525MD-A	1/2	in	2.09	13.78	2.15	2.28	12.78	2.34	0.31
		mm	53	350	55	58	325	59	8
SG-80535MD-A SGN-80535MD-A	1/2	in	2.19	13.88	2.25	2.38	12.88	2.44	0.31
		mm	56	352	57	60	327	62	8
SG-80550MD-A SGN-80550MD-A	1/2	in	2.34	14.03	2.40	2.53	13.03	2.59	0.31
		mm	59	356	61	64	331	66	8
SG-80570MD-A SGN-80570MD-A	1/2	in	2.54	14.23	2.60	2.73	13.23	2.79	0.31
		mm	65	361	66	69	336	71	8
SG-80510MD-A SGN-80510MD-A	1/2	in	1.84	14.53	1.90	1.84	13.53	1.90	0.31
		mm	47	369	48	47	344	48	8
SG-80514MD-A SGN-80514MD-A	3/4	in	2.04	14.93	2.10	2.04	13.93	2.10	0.19
		mm	52	379	53	52	354	53	5
SG-80519MD-A SGN-80519MD-A	3/4	in	2.29	15.43	2.35	2.29	14.43	2.35	0.19
		mm	58	392	60	58	367	60	5
SG-80528MD-A SGN-80528MD-A	3/4	in	2.04	16.33	2.10	2.04	15.33	2.10	0.19
		mm	52	415	53	52	389	53	5

These dimensions are average and not for construction purposes. Certified prints on request.

Section	1453
Page	1453.6
Issue	H

## SPUR GEAR PRODUCT LINE: CAST & DUCTILE IRON SEALLESS MAG DRIVE PUMPS

SG-805 Series™, SGN-805 Series™, SG-807 Series™, SGN-807 Series™

### DIMENSIONS – SG-807 SERIES™ & SGN-807 SERIES™ – MD-A (B DRIVE – FOOTED BRACKET)

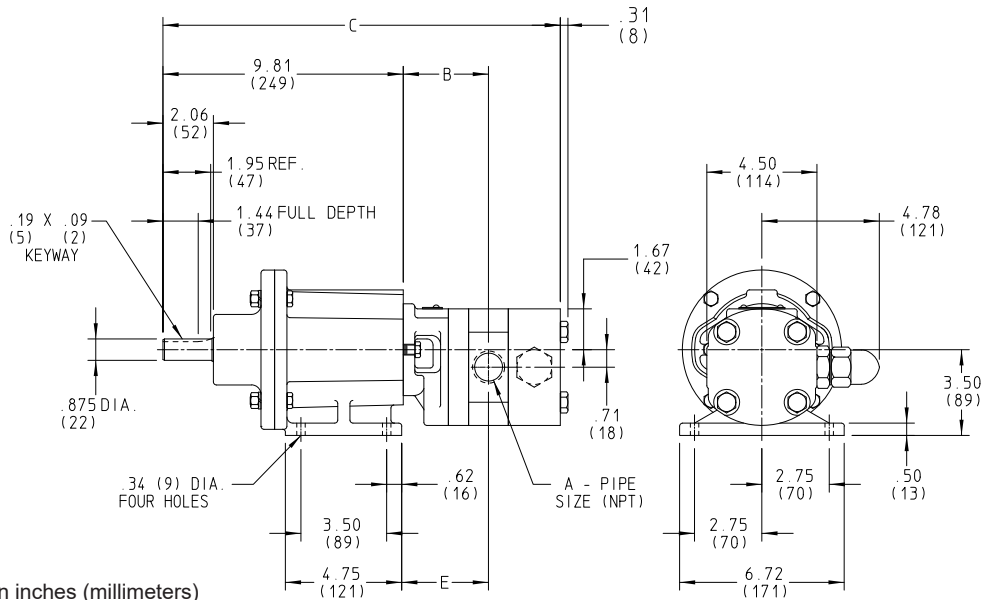

NOTE: Dimensions in inches (millimeters)

Model Number	A (in)		WITH R/V			LESS R/V		
			B	C	E	B	C	E
SG-80741MD-A SGN-80741MD-A	1	in	3.07	15.81	3.13	3.26	14.19	3.32
		mm	78	402	80	83	360	84
SG-80758MD-A SGN-80758MD-A	1	in	3.24	15.98	3.30	3.43	14.36	3.49
		mm	82	406	84	87	365	89
SG-80782MD-A SGN-80782MD-A	1	in	3.48	16.22	3.54	3.67	14.60	3.73
		mm	88	412	90	93	371	95
SG-80711MD-A SGN-80711MD-A	1	in	3.81	16.55	3.87	4.00	14.93	4.06
		mm	97	420	98	102	379	103
SG-80716MD-A SGN-80716MD-A	1	in	4.31	17.05	4.37	4.50	15.43	4.56
		mm	109	433	111	114	392	116
SG-80722MD-A SGN-80722MD-A	1½ S 1¼ D	in	4.25	20.20	4.31	4.25	18.58	4.31
		mm	108	513	109	108	472	109
SG-80732MD-A SGN-80732MD-A	1½ S 1¼ D	in	4.28	20.72	4.34	4.27	19.10	4.33
		mm	109	526	110	108	485	110

S = Suction Port  
D = Discharge Port

These dimensions are average and not for construction purposes. Certified prints on request.

# SPUR GEAR PRODUCT LINE: CAST & DUCTILE IRON SEALLESS MAG DRIVE PUMPS

SG-805 Series™, SGN-805 Series™, SG-807 Series™, SGN-807 Series™

Section	1453
Page	1453.7
Issue	H

## DIMENSIONS – SG-807 SERIES™ & SGN-807 SERIES™ – MD-B (B DRIVE – FOOTED BRACKET)

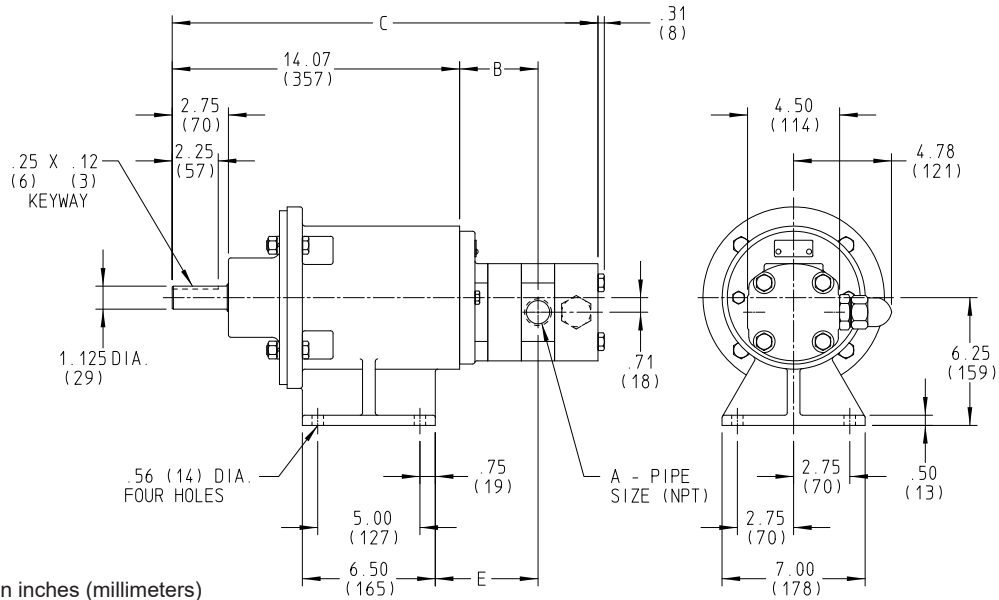

NOTE: Dimensions in inches (millimeters)

Model Number	A (in)		WITH R/V			LESS R/V		
			B	C	E	B	C	E
SG-80741MD-B SGN-80741MD-B	1	in	3.07	20.07	3.13	3.26	18.45	3.32
		mm	78	510	80	83	469	84
SG-80758MD-B SGN-80758MD-B	1	in	3.24	20.24	3.30	3.43	18.61	3.49
		mm	82	514	84	87	473	89
SG-80782MD-B SGN-80782MD-B	1	in	3.48	20.48	3.54	3.67	18.86	3.73
		mm	88	520	90	93	479	95
SG-80711MD-B SGN-80711MD-B	1	in	3.81	20.81	3.87	4.00	19.19	4.06
		mm	97	529	98	102	487	103
SG-80716MD-B SGN-80716MD-B	1	in	4.31	21.30	4.37	4.50	19.68	4.56
		mm	109	541	111	114	500	116
SG-80722MD-B SGN-80722MD-B	1½ S 1¼ D	in	4.25	24.46	4.31	4.25	22.83	4.31
		mm	108	621	109	108	580	109
SG-80732MD-B SGN-80732MD-B	1½ S 1¼ D	in	4.28	24.98	4.34	4.27	23.36	4.33
		mm	109	634	110	108	593	110

S = Suction Port

D = Discharge Port

These dimensions are average and not for construction purposes. Certified prints on request.

Section	1453
Page	1453.8
Issue	H

## SPUR GEAR PRODUCT LINE: CAST & DUCTILE IRON SEALLESS MAG DRIVE PUMPS

SG-805 Series™, SGN-805 Series™, SG-807 Series™, SGN-807 Series™

### DIMENSIONS – SG-805 SERIES™ & SGN-805 SERIES™ – MD-A NEMA C (M DRIVE – FOOTLESS BRACKET)

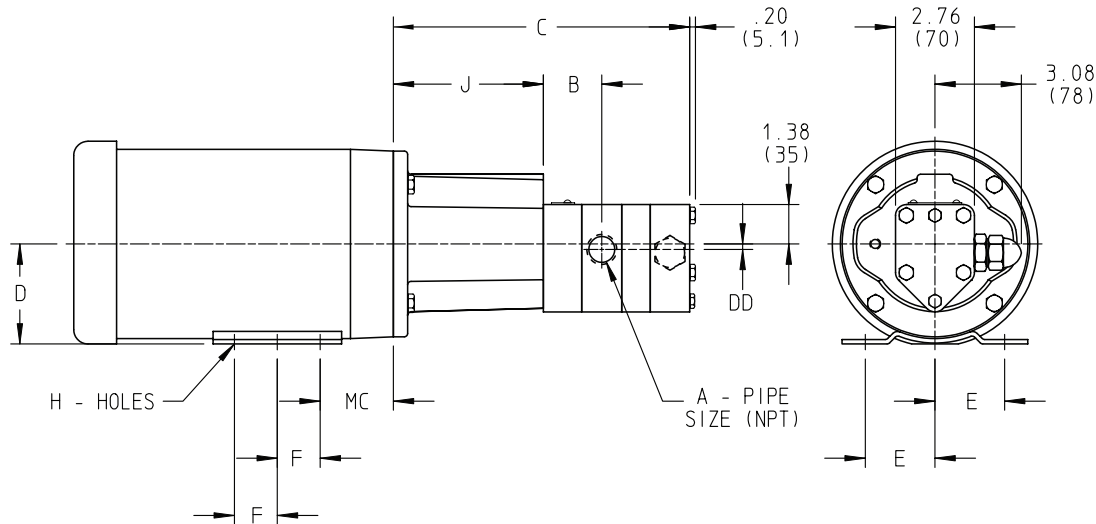

**NOTE:** Dimensions in inches (millimeters)

**NOTE:** Footless bracket requires footed motor.

Model Number	A (in)	WITH R/V		LESS R/V		DD	
		B	C	B	C		
SG-80518MD-A SGN-80518MD-A	½	in	2.02	9.15	2.21	8.15	0.31
		mm	51	232	56	207	8
SG-80525MD-A SGN-80525MD-A	½	in	2.09	9.22	2.28	8.22	0.31
		mm	53	234	58	209	8
SG-80535MD-A SGN-80535MD-A	½	in	2.19	9.32	2.38	8.32	0.31
		mm	56	237	60	211	8
SG-80550MD-A SGN-80550MD-A	½	in	2.34	9.47	2.53	8.47	0.31
		mm	59	241	64	215	8
SG-80570MD-A SGN-80570MD-A	½	in	2.54	9.67	2.73	8.67	0.31
		mm	65	246	69	220	8
SG-80510MD-A SGN-80510MD-A	½	in	1.84	9.97	1.84	8.97	0.31
		mm	47	253	47	228	8
SG-80514MD-A SGN-80514MD-A	¾	in	2.04	10.37	2.04	9.37	0.19
		mm	52	263	52	238	5
SG-80519MD-A SGN-80519MD-A	¾	in	2.29	10.87	2.29	9.87	0.19
		mm	58	276	58	251	5
SG-80528MD-A SGN-80528MD-A	¾	in	2.04	11.77	2.04	10.77	0.19
		mm	52	299	52	274	5

Motor Frame Size	D	E	F	H	J (in)	MC
56C	3.50	2.44	1.50	0.34 SLOT	5.25	2.56
	89	62	38	9		65
143TC	3.50	2.75	2.00	0.34	5.25	2.88
	89	70	51	9		73
145TC	3.50	2.75	2.50	0.34	5.25	2.88
	89	70	64	9		73
182TC	4.50	3.75	2.25	0.41	5.69	3.62
	114	95	57	10		92
184TC	4.50	3.75	2.75	0.41	5.69	3.62
	114	95	70	10		92
213TC*	5.25	4.25	2.75	0.41	5.69	4.50
	133	108	70	10		114

\* Motor shaft must be modified to resemble 182TC-184TC shaft length, diameter and key.

These dimensions are average and not for construction purposes. Certified prints on request.



# SPUR GEAR PRODUCT LINE: CAST & DUCTILE IRON SEALLESS MAG DRIVE PUMPS

SG-805 Series™, SGN-805 Series™, SG-807 Series™, SGN-807 Series™

Section	1453
Page	1453.9
Issue	H

## DIMENSIONS – SG-807 SERIES™ & SGN-807 SERIES™ – MD-A NEMA C (M DRIVE – FOOTLESS BRACKET)

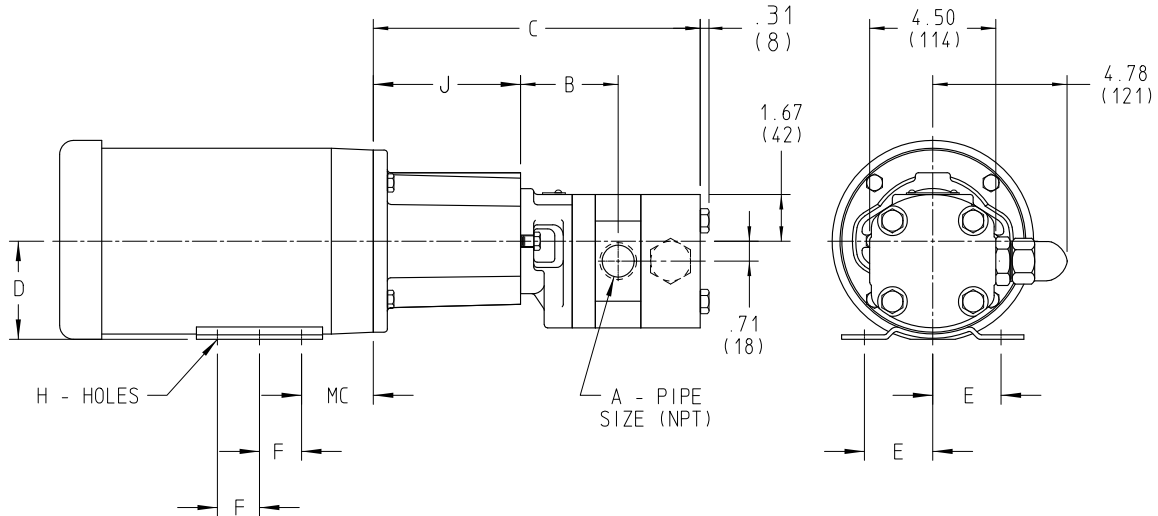

**NOTE:** Dimensions in inches (millimeters)

**NOTE:** Footless bracket requires footed motor.

Model Number	A (in)		WITH R/V		LESS R/V	
			B	C	B	C
SG-80741MD-A SGN-80741MD-A	1	in	3.07	11.25	3.26	9.63
		mm	78	286	83	245
SG-80758MD-A SGN-80758MD-A	1	in	3.24	11.42	3.43	9.80
		mm	82	290	87	249
SG-80782MD-A SGN-80782MD-A	1	in	3.48	11.66	3.67	10.04
		mm	88	296	93	255
SG-80711MD-A SGN-80711MD-A	1	in	3.81	11.99	4.00	10.37
		mm	97	305	102	263
SG-80716MD-A SGN-80716MD-A	1	in	4.31	12.49	4.50	10.87
		mm	109	317	114	276
SG-80722MD-A SGN-80722MD-A	1½ S 1¼ D	in	4.25	15.64	4.25	15.02
		mm	108	397	108	356
SG-80732MD-A SGN-80732MD-A	1½ S 1¼ D	in	4.75	16.64	4.75	15.02
		mm	121	423	121	382

Motor Frame Size	D	E	F	H	J (in)	MC
56C	3.50	2.44	1.50	0.34 SLOT	5.25	2.56
	89	62	38	9		65
143TC	3.50	2.75	2.00	0.34	5.25	2.88
	89	70	51	9		73
145TC	3.50	2.75	2.50	0.34	5.25	2.88
	89	70	64	9		73
182TC	4.50	3.75	2.25	0.41	5.69	3.62
	114	95	57	10		92
184TC	4.50	3.75	2.75	0.41	5.69	3.62
	114	85	70	10		92
213TC*	5.25	4.25	2.75	0.41	5.69	4.50
	133	108	70	10		114

\* Motor shaft must be modified to resemble 182TC-184TC shaft length, diameter and key.

These dimensions are average and not for construction purposes. Certified prints on request.

Section	1453
Page	1453.10
Issue	H

## SPUR GEAR PRODUCT LINE: CAST & DUCTILE IRON SEALLESS MAG DRIVE PUMPS

SG-805 Series™, SGN-805 Series™, SG-807 Series™, SGN-807 Series™

### DIMENSIONS – SG-807 SERIES™ & SGN-807 SERIES™ – MD-A NEMA C (M DRIVE – FOOTED BRACKET)

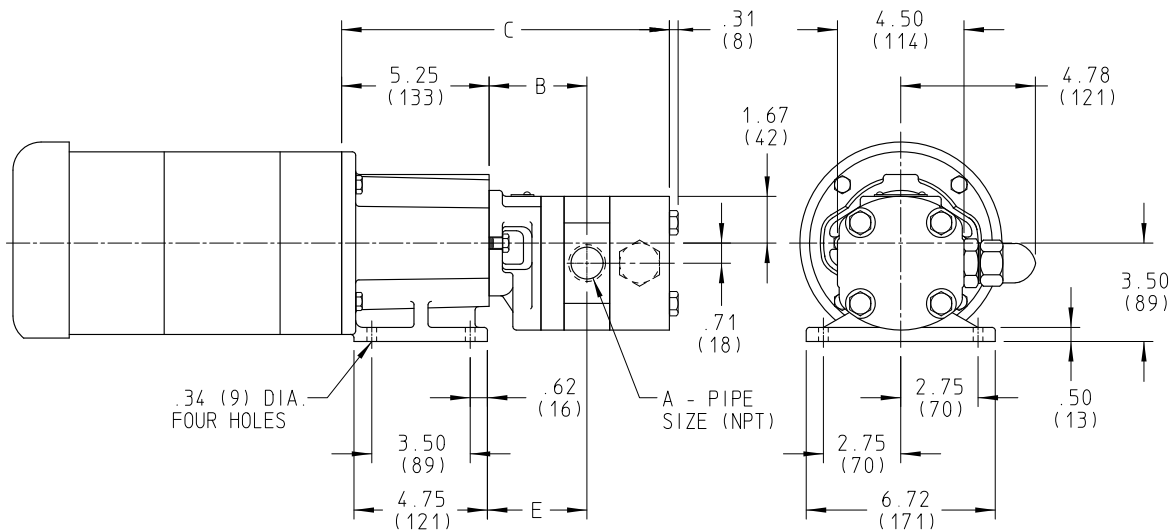

**NOTE:** Dimensions in inches (millimeters)

**NOTE:** Footed bracket requires footless motor.

Model Number	A (in)		WITH R/V			LESS R/V			Motor Frame
			B	C	E	B	C	E	
SG-80741MD-A SGN-80741MD-A	1	in	3.07	11.25	3.13	3.26	9.63	3.32	56C 143TC 145TC
		mm	78	286	80	83	245	84	
SG-80758MD-A SGN-80758MD-A	1	in	3.24	11.42	3.30	3.43	9.80	3.49	
		mm	82	290	84	87	249	89	
SG-80782MD-A SGN-80782MD-A	1	in	3.48	11.66	3.54	3.67	10.04	3.73	
		mm	88	269	90	93	255	95	
SG-80711MD-A SGN-80711MD-A	1	in	3.81	11.99	3.87	4.00	10.37	4.06	
		mm	97	305	98	102	263	103	
SG-80716MD-A SGN-80716MD-A	1	in	4.31	12.49	4.37	4.50	10.87	4.56	
		mm	109	317	111	114	276	116	
SG-80722MD-A SGN-80722MD-A	1½ S 1¼ D	in	4.25	15.64	4.31	4.25	14.02	4.31	
		mm	108	397	109	108	356	109	
SG-80732MD-A SGN-80732MD-A	1½ S 1¼ D	in	4.75	16.64	4.81	4.75	15.02	4.81	
		mm	121	423	122	121	382	122	

S = Suction Port

D = Discharge Port

Footed bracket is only available for up to NEMA 145TC frame motors (4.5" rabbet) -  
180TC and 210TC motor frames with 8.5" rabbet are only available with footless bracket.

These dimensions are average and not for construction purposes. Certified prints on request.

# SPUR GEAR PRODUCT LINE: CAST & DUCTILE IRON SEALLESS MAG DRIVE PUMPS

Section	1453
Page	1453.11
Issue	H

SG-805 Series™, SGN-805 Series™, SG-807 Series™, SGN-807 Series™

## DIMENSIONS – SG-807 SERIES™ & SGN-807 SERIES™ – MD-B NEMA C (M DRIVE – FOOTED BRACKET)

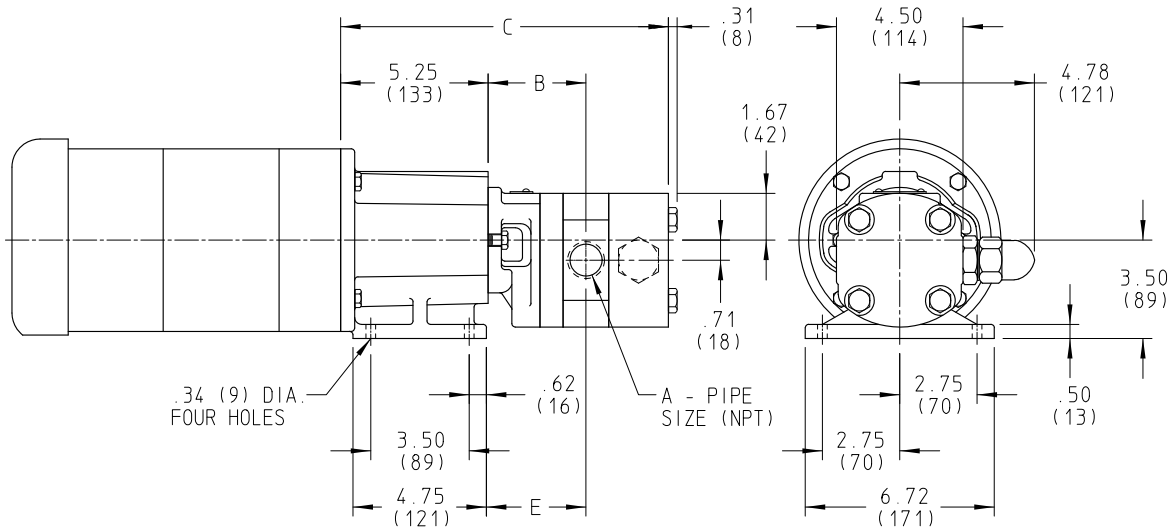

**NOTE:** Dimensions in inches (millimeters)

**NOTE:** Footed bracket requires footless motor.

Model Number	A (in)		WITH R/V			LESS R/V			DD
			B	C	E	B	C	E	
SG-80741MD-B SGN-80741MD-B	1	in	2.60	13.97	3.79	2.80	12.35	3.98	182TC/184TC 213TC/215TC 254TC/256TC ①
		mm	66	355	96	71	314	101	
SG-80758MD-B SGN-80758MD-B	1	in	2.77	14.14	3.96	2.97	12.52	4.15	
		mm	70	359	101	75	318	105	
SG-80782MD-B SGN-80782MD-B	1	in	3.01	14.38	4.20	3.21	12.76	4.39	
		mm	76	365	107	82	324	112	
SG-80711MD-B SGN-80711MD-B	1	in	3.34	14.17	4.53	3.54	13.09	4.72	
		mm	85	374	115	90	332	120	
SG-80716MD-B SGN-80716MD-B	1	in	3.84	15.20	5.03	4.04	13.59	5.22	
		mm	98	386	128	103	345	133	
SG-80722MD-B SGN-80722MD-B	1½ S 1¼ D	in	3.78	18.35	4.97	3.78	16.73	4.97	
		mm	96	466	126	96	425	126	
SG-80732MD-B SGN-80732MD-B	1½ S 1¼ D	in	4.28	19.35	5.47	4.28	17.73	5.47	
		mm	109	491	139	109	450	139	

S = Suction Port

D = Discharge Port

Coupling will accept NEMA motor frames 182TC-256TC.

① NEMA 254TC-256TC will require shaft modification reducing shaft extension by 5/8".

These dimensions are average and not for construction purposes. Certified prints on request.

Section	1453
Page	1453.12
Issue	H

## SPUR GEAR PRODUCT LINE: CAST & DUCTILE IRON SEALLESS MAG DRIVE PUMPS

SG-805 Series™, SGN-805 Series™, SG-807 Series™, SGN-807 Series™

### NPSH REQUIRED

Printed performance curves are not available.

Performance curves can be electronically generated with the Viking Pump Curve Generator on [vikingpump.com](http://vikingpump.com).

NPSH<sub>R</sub> data is not available on the curve generator.

### SELECTING THE CORRECT VIKING MAG DRIVE® COUPLING

1. Find pump HP and speed from the performance curves, which can be electronically generated with the Viking Pump Curve Generator, located on [www.vikingpump.com](http://www.vikingpump.com).

2. Calculate the application torque (T), using this formula:

$$T \text{ (FT-LB)} = \frac{\text{HP}}{\text{SPEED}} \times 5252$$

3. Select the temperature correction factor (TCF) from Table 1 or Table 2.

STANDARD NEODYMIUM MAGNETS (For Application Temperatures Below 225°F.)							
Application Temp. (°F)	AMB	100	125	150	175	200	225
Application Temp. (°C)	20	38	52	66	79	93	107
TCF	1.0	.94	.88	.82	.76	.70	.64

Table 1: Temperature Correction Factors

OPTIONAL SAMARIUM COBALT MAGNETS (For Application Temperatures Above 225°F.)					
Application Temp. (°F)	175	200	300	400	500
Application Temp. (°C)	79	93	149	204	260
TCF	.74	.73	.69	.63	.59

Table 2: Temperature Correction Factors

4. Divide calculated application torque by TCF to get adjusted application torque.

5. Select coupling with rating equal to or greater than "adjusted application torque" (AAT) from Table 3. Viking couplings have a built-in service factor, so if you have calculated the AAT correctly, you can be comfortable with a coupling that is equal to your calculated torque.

MAGNETIC COUPLING TORQUE RATING TABLE		
Coupling Size	Torque (FT-LBS)	Nm
MD-A4	4	5.4
MD-A9	9	12.2
MD-B40	40	54.2

Table 3

### EXAMPLE

1. An application calls for pumping 1 GPM of 100 SSU (22 cSt) liquid at 400 PSI (27 Bar), at 100°F (38C), with a 1750 RPM motor. From the pump selector, an SG-80525 is selected, providing .95 GPM (3.6 LPM) at 1750 RPM, with .35 BHP (.26 kW).

2. Calculate torque (T).

$$\begin{aligned} \text{TORQUE (T)} &= \frac{.35}{1750} \times 5252 \\ &= 1.05 \text{ FT-LB} \end{aligned}$$

3. From the temperature correction factor table, the correction factor (TCF) = .94.

4. Calculate adjusted application torque.

$$\begin{aligned} \text{ADJUSTED APPLICATION TORQUE} &= \frac{1.05}{.94} \\ &= 1.12 \text{ FT-LB} \end{aligned}$$

5. Select coupling.

THE NEODYMIUM MD-A4 (4 FT-LB RATING > 1.12 FT-LB AAT) COUPLING IS THE PROPER SELECTION