

**UNIVERSAL PRODUCT LINE:
STAINLESS STEEL — MAG DRIVE PUMPS
8127A SERIES™**

Section	1703
Page	1703.1
Issue	E

TABLE OF CONTENTS

Features & Benefits 2
 Model Number Key 2
 Port Location Options 2
 Cutaway View & Pump Features 3
 Standard Materials of Construction 4
 Special Materials & Options Selection Guidelines 5
 Specifications 5
 Dimensions – Sizes H through LS 6
 Dimensions – Size Q 7
 Dimensions – Size QS 7
 NPSH Required 8
 Selecting the Correct Viking Mag Drive® Coupling 9
 Example 9

SERIES DESCRIPTION

The 8127A Series™ is the ideal sealing technology within Viking’s Universal Product Line pumps. It is dimensionally interchangeable with other Universal Product Line pumps, allowing an easy upgrade from packed or mechanical seals to sealless technology.

The 8127A Series™ canister is hermetically sealed, providing the highest level of liquid containment available by eliminating traditional dynamic shaft seals traditionally associated with hazardous, hard-to-seal, or expensive liquids. It also eliminates housekeeping issues and downtime due to seal failure. This product is designed to handle a broad range of applications (such as caustics, isocyanates, adhesives, solvents and mercaptans) requiring continuous duty at pressures up to 150 PSI (10 Bar)

This series features 9 different sizes with flows to 500 GPM (114 m³/h) They may be applied to both thin and thick liquids, and operate in either direction. They are also capable of operating under suction lift conditions. The 8127A Series™ continues the tradition of most robust line of internal gear pumps built by Viking Pump®.

RELATED PRODUCTS

- Stainless Steel, Non-Jacketed Pumps: Catalog Section 1701
- Cast Iron, Mag Drive Pumps: Catalog Section 1403
- Steel Externals, Mag Drive Pumps: Catalog Section 1303

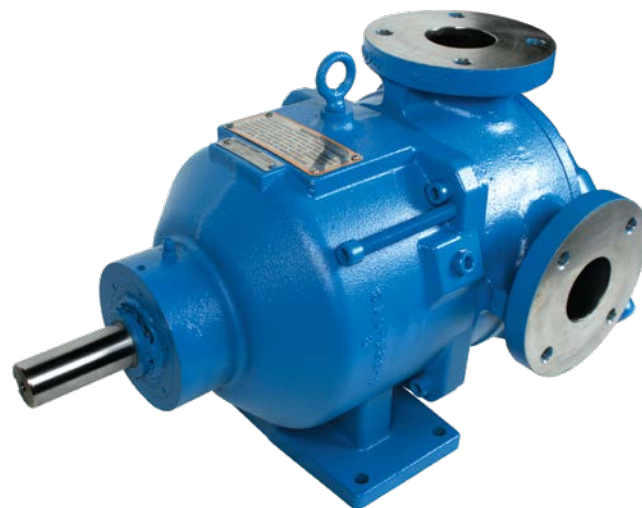

LQ8127A

OPERATING RANGE

SERIES	NOMINAL FLOW		MAXIMUM PRESSURE		TEMPERATURE RANGE		VISCOSITY RANGE*	
	GPM	m³h	PSI	Bar	°F	°C	SSU	cSt
8127A	15 - 500	3.4 - 114	150	10	-120 to +500	-85 to +260	28 to 250,000	1 to 55,000

* Samarium cobalt magnets required for temperatures over 225° F (105°C)

Section	1703
Page	1703.2
Issue	E

UNIVERSAL PRODUCT LINE: STAINLESS STEEL — MAG DRIVE PUMPS

8127A SERIES™

FEATURES & BENEFITS

- Positive displacement, internal gear pumping principle.
- Gear and pump geometry has been optimized based on more than 100 years of experience. These pumps are designed to provide exceptional reliability and freedom from down time and maintenance.
- Drop in foot print allows direct replacement of a Viking Universal Seal pump without re-piping.
- Foot-mounted design.
- Available with 90° ports, which can be rotated in 90° degree increments, or with 180° ports (Check individual sizes).
- Ports are threaded or flanged.
- Pumps come with an adjustable internal pressure relief valve on standard design.
- The pump operates in either direction, allowing one pump to be used for both loading and unloading. There is a slight reduction in capacity at viscosities less than 100 SSU with counter-clockwise rotation.
- Adjustable end clearance for fluid viscosity or temperature by use of head shims.
- Static O-rings at key points assures liquid containment.
- Pumps conforming to ATEX hazard prevention requirements are available
- Short-term Run-dry Capability. Unlike many mag drive pumps, the 8127A Series™ may be run dry for short periods, such as for clear lines when unloading, or in the case of accidental empty tank situations.

PORT LOCATION OPTIONS

Revolvable Pump Casings Standard on H through LS Sizes

All 8127A Series™ pumps are equipped with pump casings that can be positioned to meet common piping configurations. H through Q sizes have standard 90° ports which can be turned to any of four positions. The QS size has standard 180° ports with an option of 90° ports allowing you to achieve any of four positions, like the other sizes. Optional opposite ports are available on other sizes and materials. Direction of flow is reversible so any given port can be used as suction or discharge. The relief valve must “point “ to the suction port in all cases.

* H, HL, K, KK, LQ & LL ports can't face down.

90° port options:

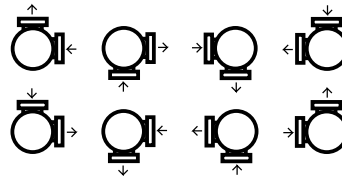

Opposite ports:

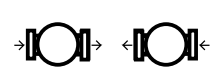

Viking Universal Product Line pumps carry a three year limited warranty. See catalog section 000 for details.

MODEL NUMBER KEY

L	S	8	1	2	7	A-325
Size:		Shaft Sealing:		Basic Series Configuration		Series Edition:
H	LQ	8 = Sealless				A = Original Design
HL	LL					
K	LS		Jacketing:		Material of Construction:	Torque Specifications:
KK	Q		1 = Non-Jacketed Bracket		7 = Stainless Steel	H-HL = 40 Ft-lb
	QS					K-KK = 90 Ft-lb
						K-KK = 180 Ft-lb
						LQ-LS = 325 Ft-lb
						Q-QS = 425 Ft-lb
						Q-QS = 900 Ft-lb

Note: Model numbers for the 8127A Series™ begin with the size, followed by the pump series. The last number of the series indicates the material of construction for the external components. This is followed by the coupling and drive unit designations.

Neodymium iron boron magnets are the standard. For application temperatures over 225°F (105°C), Samarium Cobalt magnets are available in all sizes.

**UNIVERSAL PRODUCT LINE:
STAINLESS STEEL — MAG DRIVE PUMPS**
8127A SERIES™

Section	1703
Page	1703.3
Issue	E

CUTAWAY VIEW & PUMP FEATURES

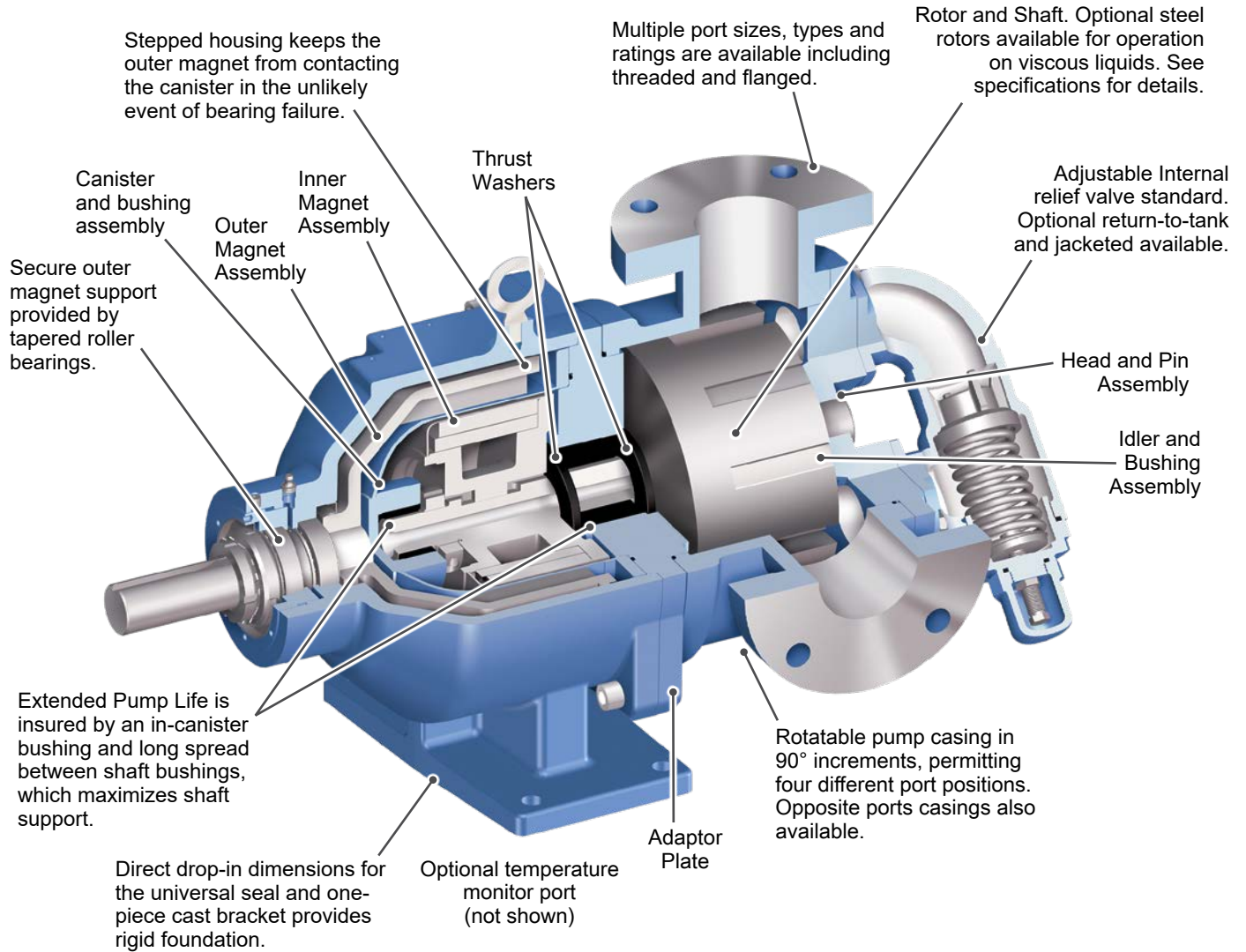

H through LS hollow shaft circulation illustrated below. Q & QS circulation is reversed - not illustrated (idler pin open to discharge port).

Positive Cooling Flow
(indicated by small arrows) minimizes potential for thermal product degradation and to cool the magnet area. Pressure differential from the discharge side causes a cooling flow between the pump shaft and bushing, and the canister and magnet through the shaft interior and hollow idler pin back to the pump suction. This cooling flow is reversed when the pump's direction of flow is reversed.

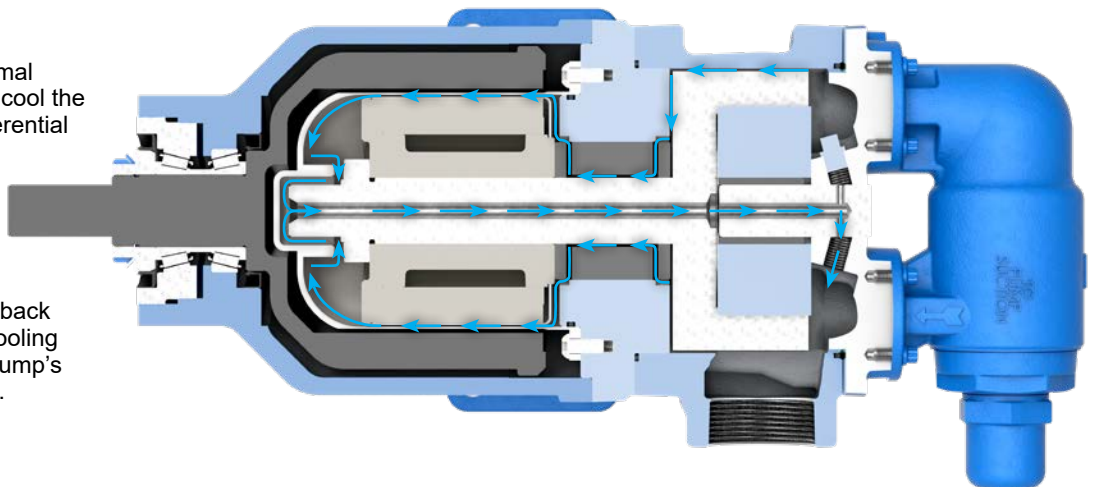

Section	1703
Page	1703.4
Issue	E

**UNIVERSAL PRODUCT LINE:
STAINLESS STEEL — MAG DRIVE PUMPS
8127A SERIES™**

STANDARD MATERIALS OF CONSTRUCTION

Component	Standard Material	
Casing	Stainless Steel, ASTM A743, Grade CF8M	
Head	Stainless Steel, ASTM A743, Grade CF8M, Case Hardened	
Bracket	Cast Iron, ASTM A48, Class 35B	
Idler	Standard	Stainless Steel, ASTM A743, Grade CF8M, Case Hardened
	Optional	Non-Galling Stainless and PPS Composite
Rotor	Stainless Steel, ASTM A743, Grade CF8M, Case Hardened	
Rotor Shaft	Hard Coated Stainless Steel, ASTM A276, Type 316 Hard Coated	
Idler Pin	Hard Coated Stainless Steel, ASTM A276, Type 316 Hard Coated	
Idler Bushing	Standard	Carbon Graphite
	Optional	Silicon Carbide
Internal Pressure Relief Valve	Stainless Steel, ASTM A743, Grade CF8M	
Canister	316L Stainless Steel	
Canister Bushing	Standard	Carbon Graphite
	Optional	Siliconized Graphite
Thrust Washers	① Silicon Carbide	
Coupling Magnets	Standard	Neodymium Iron Boron
	Optional	Samarium Cobalt
O-Rings	Standard	PTFE (Derivative) Encapsulated
	Optional	FKM, FFKM
Adaptor Plate	Stainless Steel, ASTM A743, Grade CF8M	
Adaptor Bushing	Standard	Carbon Graphite
	Optional	Silicon Carbide

① Q & QS contains two sets of thrust washers, one set is carbon graphite as standard.

**UNIVERSAL PRODUCT LINE:
STAINLESS STEEL — MAG DRIVE PUMPS
8127A SERIES™**

Section	1703
Page	1703.5
Issue	E

SPECIAL MATERIALS & OPTIONS SELECTION GUIDELINES

For High Viscosities - Above 2,500 SSU (550 cSt)

- Extra clearances required, depending on viscosity. Contact factory for clearance specifications.
- Larger ports may be required depending on suction conditions.
- Pump should be operated at slower than normal speeds, which may require a larger pump.

For Low Viscosities or Non-Lubricating Liquids – Below 100 SSU (20 cSt)

- Carbon graphite bushings.
- Silicon carbide thrust washers.

For High Temperatures – Above 225° F (105°C)

- Samarium cobalt magnets required. Maximum temperature is 500°F (260°C), contact factory for special material requirements for temperatures above 400°F (205°C)
- High temperature elastomers – FKM up to 350°F (175°C); PTFE up to 400°F (205°C); or FFKM up to 550°F (290°C);
- High temperature relief valve above 350°F (175°C).
- High temperature bushings recommended depending on temperature, size and specific material. See ESB-3 for recommendations.
- Additional operating clearances may be required depending on temperature, size and specific material. See ESB-2 for recommendations.

SPECIFICATIONS

Model Number	③ Standard Port Size Inches	④ Capacity at Maximum Rated Speed GPM m ³ /h RPM			Maximum Hydrostatic Pressure PSIG BAR		① Maximum Discharge Pressure PSIG BAR		② Maximum Recommended Temperature for Standard Pump				Approx. Shipping Weight with Valve Lbs. Kg.	
									Standard Construction		High Temperature Construction			
									°F	°C	°F	°C		
H8127A	1.5 (40)	15	3.4	1750	400	28	150	10	225	107	500	260	70	32
HL8127A	1.5 (40)	30	6.8	1750	400	28	150	14	225	107	500	260	70	32
K8127A	2 (50)	80	18	780	400	28	150	10	225	107	500	260	205	93
KK8127A	2 (50)	100	23	780	400	28	150	10	225	107	500	260	205	93
LQ8127A	2.5 (65)	135	30	640	400	28	150	10	225	107	500	260	295	134
LL8127A	3 (75)	170	39	640	400	28	150	10	225	107	500	260	315	143
LS8127A	3 (75)	200	45	640	400	28	125	9	225	107	500	260	350	159
Q8127A	4 (100)	300	68	520	400	28	125	9	225	107	500	260	730	331
QS8127A	6 (150)	500	114	520	400	28	125	9	225	107	500	260	805	365

- ① For maximum recommended discharge pressures see performance curves, which can be electronically generated with the Viking Pump Curve Generator, located on www.vikingpump.com.
- ② Extra clearances are required above 225°F. Higher temperatures can be handled with special construction, consult factory.
- ③ Ports are suitable for ANSI Class 150 stainless steel companion flanges or flanged fittings. Other options are available, consult factory.
- ④ Nominal capacity on medium viscosity liquids with clockwise rotation.
There is a slight reduction in capacity at viscosities less than 100 SSU with counter-clockwise rotation.

Section	1703
Page	1703.6
Issue	E

**UNIVERSAL PRODUCT LINE:
STAINLESS STEEL — MAG DRIVE PUMPS**
8127A SERIES™

DIMENSIONS – SIZES H THROUGH LS

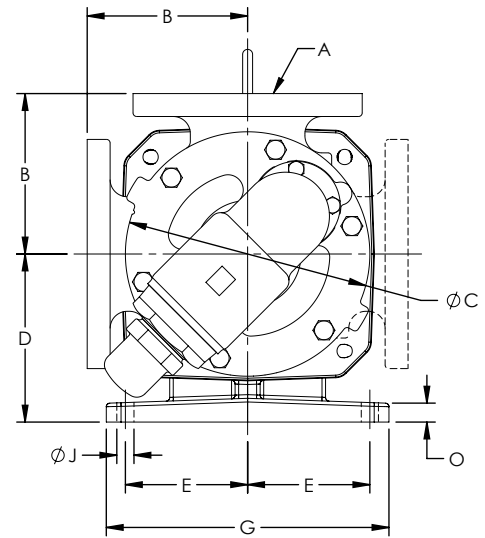
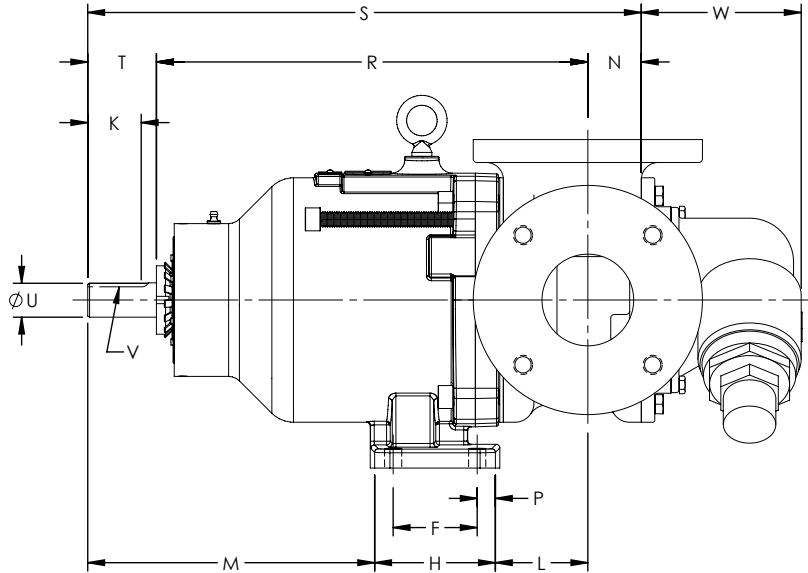

Model Number	A (in)	B	C	D	E	F	G	H	J	K	L	M	N	O	P	R	S	T	②U	V	W	
H8127A HL8127A	1.5	in	4.00	4.75	3.50	2.75	2.25	6.75	3.50	0.47	0.99	3.38	5.19	1.19	0.56	0.63	10.45	13.26	1.62	0.75	.19 x .09	2.90
		mm	102	121	89	70	57	171	89	12	25	86	132	30	14	16	266	337	41	19		74
K8127A KK8127A	2	in	5.25	8.00	5.50	4.00	2.75	9.25	3.95	0.56	1.42	3.03	9.39	1.75	0.62	0.60	14.12	18.12	2.25	1.13	.25 x .12	5.25
		mm	133	203	140	102	70	235	100	14	36	77	239	44	16	15	359	460	57	28		133
LQ8127A	① 2.5	in	7.19	10.25	7.00	4.38	4.00	10.00	5.40	0.56	2.55	3.37	9.11	1.75	0.62	0.63	14.50	19.63	3.38	1.44	.38 x .19	5.40
		mm	183	260	178	112	102	254	137	14	65	86	231	44	16	16	369	499	86	36		137
LL8127A	① 3	in	7.19	10.25	7.00	4.38	4.00	10.00	5.40	0.56	2.55	3.37	9.11	2.25	0.62	0.63	14.50	20.13	3.38	1.44	.38 x .19	5.40
		mm	183	260	178	112	102	254	137	14	65	86	231	57	16	16	369	511	86	36		137
LS8127A	① 3	in	7.19	10.25	7.00	4.38	4.00	10.00	5.40	0.56	2.55	4.74	9.11	2.44	0.62	0.63	15.87	21.69	3.38	1.44	.38 x .19	5.40
		mm	183	260	178	112	102	254	137	14	65	120	231	62	16	16	403	551	86	36		137

① Series 8127A ports are suitable for 150# ANSI steel or stainless steel companion flanges or flanged fittings.

② When replacing on existing units, sizes L, LL and LQ may require a different size coupling half.

These dimensions are average and not for construction purposes. Certified prints on request.

**UNIVERSAL PRODUCT LINE:
STAINLESS STEEL — MAG DRIVE PUMPS**
8127A SERIES™

Section	1703
Page	1703.7
Issue	E

DIMENSIONS – SIZE Q

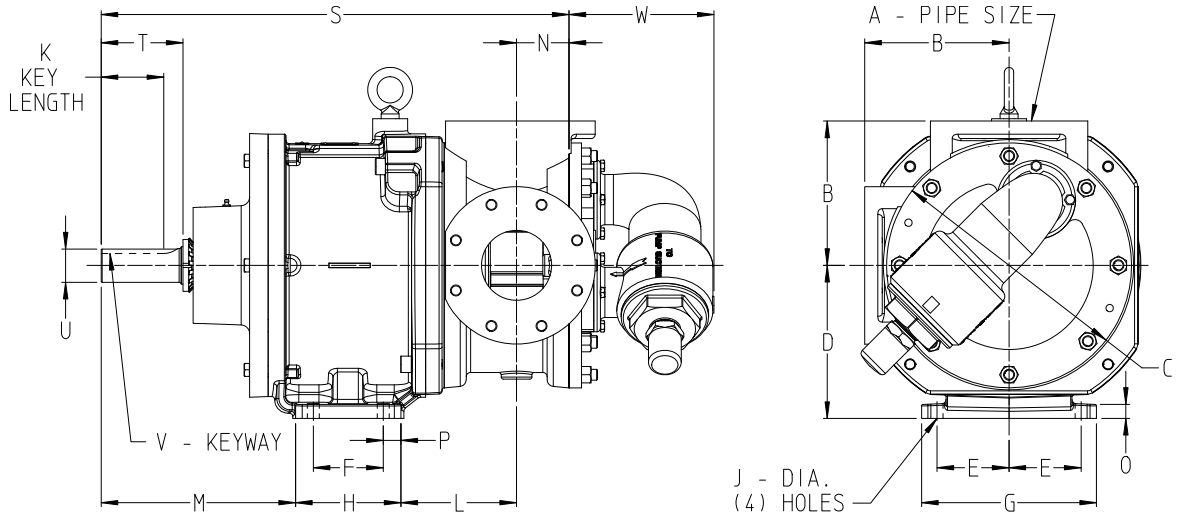

Model Number	A (in)		B	C	D	E	F	G	H	J	K	L	M	N	O	P	S	T	④U (in)	V (in)	W
Q8123A	①	in	8.25	14.00	8.75	4.12	4.00	10.00	6.00	0.69	3.58	6.62	11.13	3.00	0.80	1.00	26.75	4.68	1.94	.50 x .25	8.29
	1.5	mm	210	356	222	105	102	254	152	18	91	168	283	76	20	25	679	119			

DIMENSIONS – SIZE QS

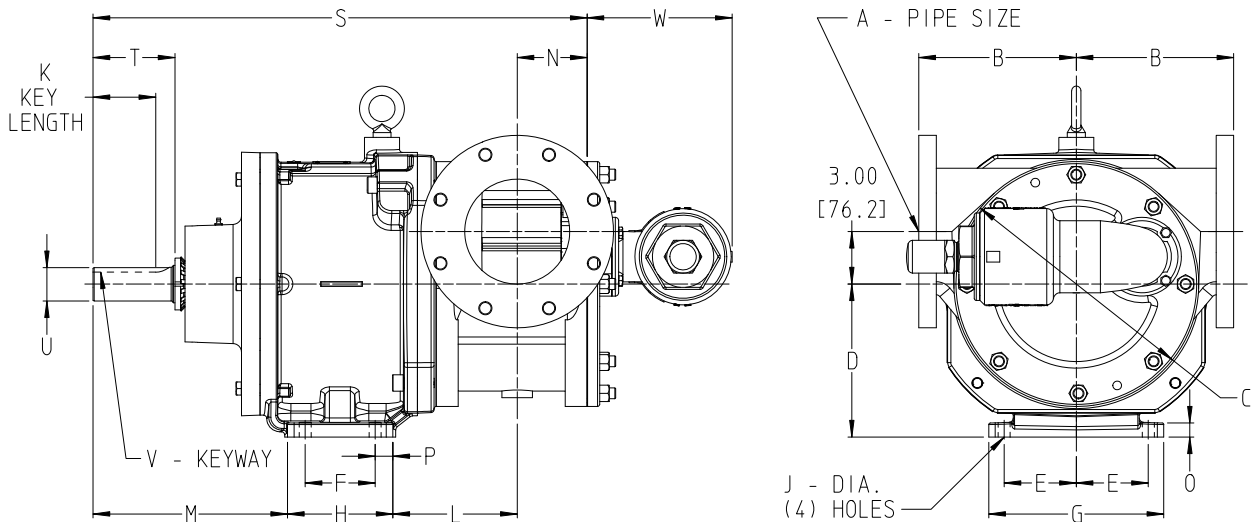

Model Number	A (in)		B	C	D	E	F	G	H	J	K	L	M	N	O	P	S	T	④U (in)	V (in)	W
QS8123A	①	in	9.00	14.00	8.75	4.12	4.00	10.00	6.00	0.69	3.58	7.12	11.13	4.00	0.80	1.00	28.25	4.68	1.94	.50 x .25	8.29
	1.5	mm	229	356	222	105	102	254	152	18	91	181	283	102	20	25	718	119			

① Ports are suitable for use with Class 150 ANSI stainless steel flanges or flanged fittings.

These dimensions are average and not for construction purposes. Certified prints on request.

Section	1703
Page	1703.8
Issue	E

**UNIVERSAL PRODUCT LINE:
STAINLESS STEEL — MAG DRIVE PUMPS
8127A SERIES™**

NPSH REQUIRED

Printed performance curves are not available.

Performance curves can be electronically generated with the Viking Pump Curve Generator on vikingpump.com.

NPSH_R data is not available on the curve generator.

NPSH (Net Positive Suction Head): The NPSH_R (Net Positive Suction Head Required by the pump) is given in the table below and applies for viscosities through 750 SSU. NPSH_A (Net Positive Suction Head – Available in the system) must be greater than the NPSH_R. For a complete explanation of NPSH, see Application Data Sheet AD-19.

FOR VISCOSITIES UP TO 750 SSU – See NPSH_R table below.

NPSH_R for high viscosities can be estimated using the following method:

1. Calculate line loss for a 1 foot long pipe of a diameter matching the pump inlet port size. Use your flow rate and max viscosity.
2. Convert this value into Feet of Liquid (S.G. 1.0)
3. Add this value to the NPSH_R value in the chart below.

NPSH_R – FEET OF LIQUID (Specific Gravity 1.0), Viscosities up to 750 SSU

PUMP SIZE	PUMPS SPEED, RPM														
	100	125	155	190	230	280	350	420	520	640	780	950	1150	1450	1750
H, HL	—	—	—	—	1.7	1.8	1.9	2.1	2.4	2.8	3.4	4.5	6.2	9.5	13.5
K, KK	—	1.7	1.8	1.9	2.1	2.3	2.8	3.3	4.4	6.3	9.1	—	—	—	—
LQ	1.6	1.8	2.0	2.2	2.5	3.0	3.8	5.0	7.3	10.8	—	—	—	—	—
LL	1.6	1.8	2.0	2.2	2.5	3.0	3.8	5.0	7.3	—	—	—	—	—	—
LS	1.6	1.8	2.0	2.2	2.5	3.0	3.8	5.0	7.3	10.8	—	—	—	—	—
Q, QS	1.9	2.1	2.3	2.7	3.3	4.2	6.1	8.4	12.7	—	—	—	—	—	—

**UNIVERSAL PRODUCT LINE:
STAINLESS STEEL — MAG DRIVE PUMPS
8127A SERIES™**

Section	1703
Page	1703.9
Issue	E

**SELECTING THE CORRECT
VIKING MAG DRIVE® COUPLING**

1. Find pump HP and speed from the performance curves, which can be electronically generated with the Viking Pump Curve Generator, located on www.vikingpump.com.

2. Calculate the application torque (T), using this formula:

$$T \text{ (FT-LB)} = \frac{\text{HP}}{\text{SPEED}} \times 5252$$

3. Select the temperature correction factor (TCF) from Table 1 or Table 2.

STANDARD NEODYMIUM MAGNETS (For Application Temperatures Below 225°F.)							
Application Temp. (°F)	AMB	100	125	150	175	200	225
TCF	1.0	.94	.88	.82	.76	.70	.64

Table 1: Temperature Correction Factors

OPTIONAL SAMARIUM COBALT MAGNETS (For Application Temperatures Above 225°F.)					
Application Temp. (°F)	175	200	300	400	500
TCF	.74	.73	.69	.63	.59

Table 2: Temperature Correction Factors

4. Divide calculated application torque by TCF to get adjusted application torque.

5. Select coupling with rating equal to or greater than “adjusted application torque” from Table 3.

MAGNETIC COUPLING TORQUE RATING TABLE	
Pump Size	Torque (FT-LBS)
H & HL	40
K & KK	90
	180
L, LQ, LL, LS	325
Q & QS	425
	900

Table 3

EXAMPLE

1. An HL8127A is required to pump 30 GPM of 20 cSt liquid at 1750 RPM, 50 PSI differential pressure

Temperature is 150°F.

From the pump selector, required HP is 2.8.

2. Calculate torque (T).

$$\begin{aligned} \text{TORQUE (T)} &= \frac{2.8}{1750} \times 5252 \\ &= 8.40 \text{ FT-LB} \end{aligned}$$

3. From the temperature correction factor table, the correction factor (TCF) = .82.

4. Calculate adjusted application torque.

$$\begin{aligned} \text{ADJUSTED APPLICATION TORQUE} &= \frac{8.40}{0.82} \\ &= 10.25 \text{ FT-LB} \end{aligned}$$

5. Select coupling.

THE NEODYMIUM 40 FT-LB COUPLING IS THE PROPER SELECTION