

O-PRO® SEAL TECHNOLOGY

O-PRO® SEAL TECHNOLOGY – SIMPLE, PROVEN & RELIABLE

Viking Pump is the leader in internal gear innovation and the latest development is the patented O-Pro® Seal technology. O-Pro® Seals utilize a series of O-rings to create a robust seal and lubrication chamber, all in one. O-Pro® Barrier seal functions as both a seal and bracket bushing; while the O-Pro® Guard seal is a simple retrofit option.

O-PRO® BARRIER SEAL

HOW IT WORKS:

O-Pro® Barrier seal replaces packing or mechanical seal by occupying the internal bracket cavity with a machined seal gland, utilizing O-rings to seal externally on the bracket and internally on the shaft. A combination of O-rings and lubricating fluid provide a robust seal preventing process fluid from leaking out of the pump. O-Pro® Barrier design also contains lubrication between the shaft and bushing reducing wear.

The O-Pro® Barrier seal, made of hardened cast iron, combines a bracket bushing and seal gland, with double O-ring seals, to stop process fluids from entering the bracket and eventually leaking from the pump.

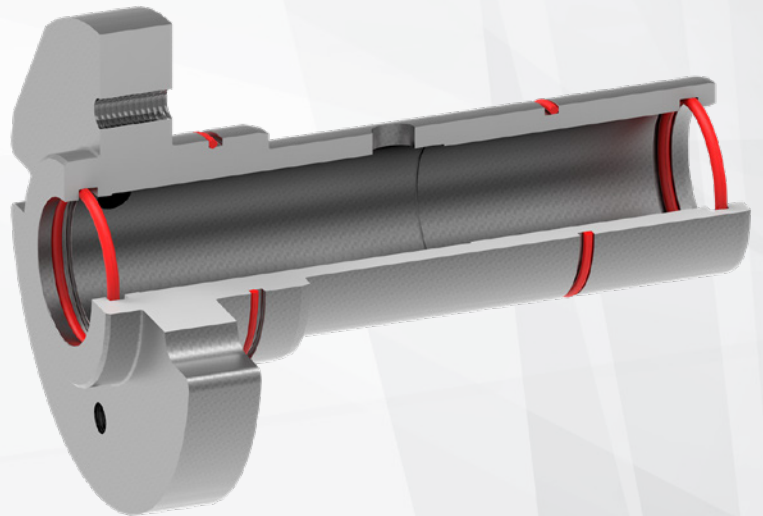

O-PRO® GUARD SEAL

HOW IT WORKS:

O-Pro® Guard seal replaces packing or mechanical seal by sealing between the bracket, sleeve & shaft surfaces with a series of O-rings. The series of O-rings and lubrication provide a robust seal for many applications. The stainless steel construction utilizes a sleeve that is secured to the shaft to address any shaft wear concerns to ensure superior performance.

The O-Pro® Guard seal is a compact design for an easy retrofit answer for a leaking pump. Stainless steel construction provides compatibility in many applications.

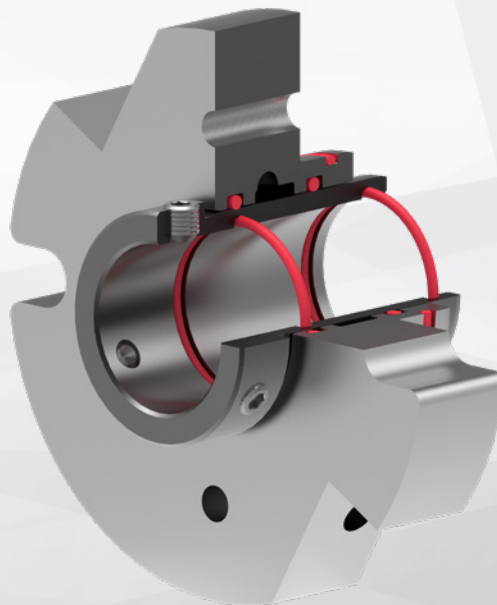

O-PRO® BARRIER

O-Rings trap clean lubrication **inside** the seal to reduce wear between the shaft and the bracket bushing, keeping all parts in optimal condition.

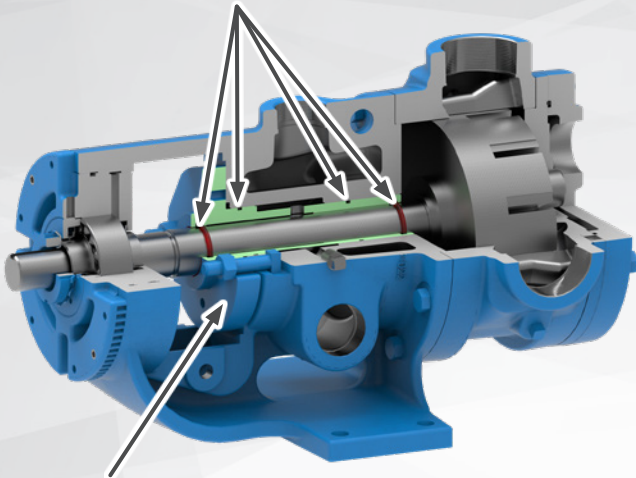

Back-pull-out bracket bushing for ease of seal replacement, jackscrews available for removal

O-PRO® GUARD

Existing bracket bushing is utilized; packing is removed, and seal is installed in place of packing gland.

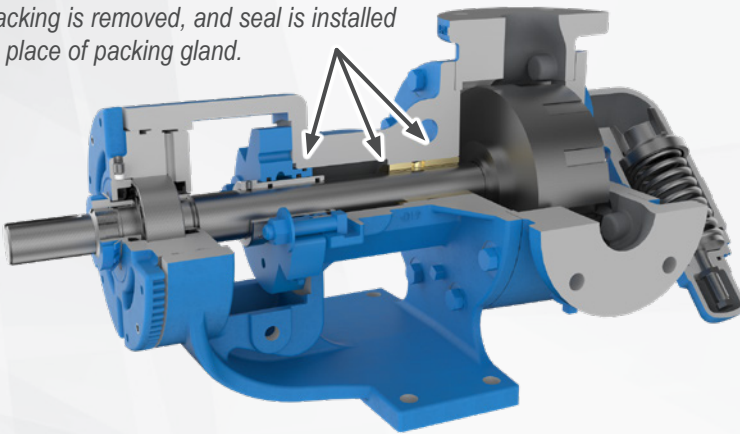

MAINTENANCE

All O-Pro® seals should be re-greased every 500 hours. The relief fitting enables visual inspection of the grease to ensure no process fluid leaks. Periodic re-tensioning is not required. O-Pro® seals may be removed with the pump in place to replace O-rings, by removing the bearing housing. Spacer couplings are required to provide enough room to remove the O-Pro® Barrier completely. Spacer couplings are not needed if the rotor/shaft is removed from the head end of the pump, which also makes it easier to re-install the O-Pro® Barrier and then re-install the rotor/shaft.

RETROFITABILITY

The following existing Viking pump series may be retrofitted to utilize the O-Pro® seals:

124A Series™	127A Series™
4124A Series™	4127A Series™
224A Series™	227A Series™
4224A Series™	4227A Series™
324A Series™	327A Series™
4324A Series™	4327A Series™

Kits are available with all parts needed for conversion. If shafts are worn, new rotor/shafts may be required for conversion to ensure sealing. Q and QS size brackets may require modification or replacement, if using the O-Pro® Barrier, which is not included in the kits.

TYPICAL APPLICATIONS

Inks, paints, molasses, edible oils, corn syrup, honey, lube oil, grease, asphalt, wax, resins, starch, fats, isocyanates, adhesives and many more!

KIT PART NUMBERS

Seal Type	H-HL	K-KK	L-LL	LS	Q-QS	M	N	R-RS
O-Pro® Barrier	3-464-SEAL-K450	3-464-SEAL-K451	3-464-SEAL-K452 (K452: 1 7/16")	3-464-SEAL-K453	3-464-SEAL-K454	N/A	3-464-SEAL-K471	3-464-SEAL-K472
O-Pro® Guard	3-464-SEAL-K482	3-464-SEAL-K483	3-464-SEAL-K484	3-464-SEAL-K485	3-464-SEAL-K486	3-464-SEAL-K487	3-464-SEAL-K488	3-464-SEAL-K489

MAXIMUM RPM

Seal Type	H	HL	K	KK	L	LQ	LL	LS	Q	QS	N	R	RS
O-Pro® Barrier	1000	1000	780	780	640	640	520	640	470	470	330	260	260
O-Pro® Guard	760	760	520	520	N/A	520	520	520	350	350	280	225	225