

# AUTOMATED GUIDED CART



## TOW CAPACITY

2000 lbs

## PERFORMANCE

"Backpack" system tows loads from underneath, keeping load off of the cart

Automated mechanical rack interchange system (*custom rack design available*)

RFID checkpoints for inspection

Integrates with most database-driven MES/ERP systems

## SAFETY FEATURES

Emergency stop button

Laser scanning for collision avoidance

## TRAVEL

3 mph max speed

Tractor-style turning system

Floor-mounted magnetic tape path

Auto-recharge system and dock station

## STANDARD COLORS

 RAL 9003 - Signal White



## TECHNICAL

# AUTOMATED GUIDED CART

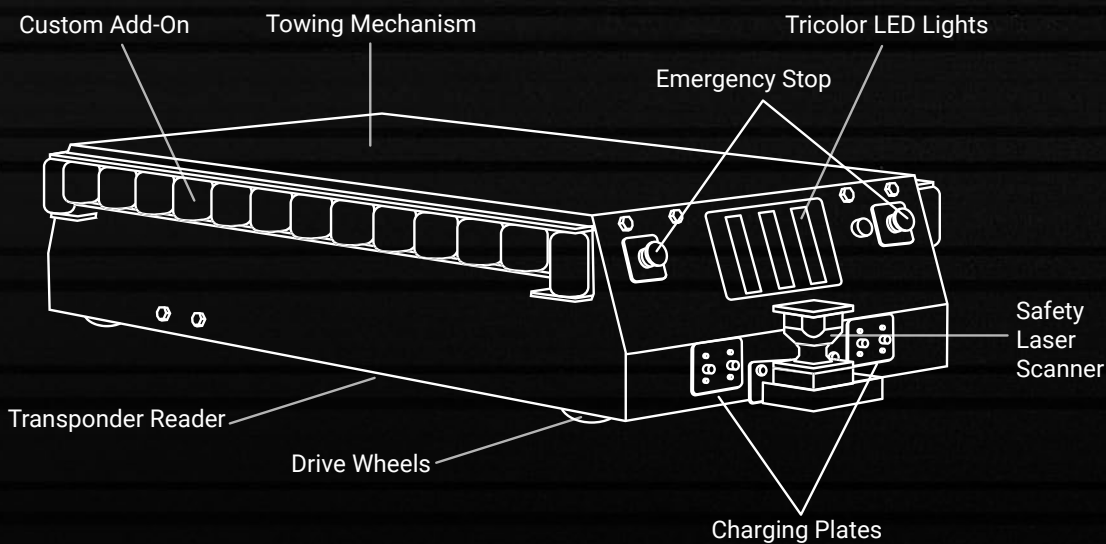

## SPECS

Virtual Brake System  
Motor - Dual Drive 250 Volt 3 Phase  
Path - Magnetic Tape w/RFID Tag Reader  
Portable Control Via Tablet and Ignition Software  
Tri-Colored LED Lights for Quick Diagnostics  
Safety Laser Scanners  
Towing Mechanism  
Customizable Audio  
Opportunity or Mandatory Scheduled Charging with External Charging System



### Web-Based Integration and Management Software

- Web-Based Deployment
- Security & Stability
- Real-Time Control & Monitoring
- Expandable & Scalable

*Specifications may vary based on system configuration and workload.*