



# Cast Iron

## Essentials Guide

How to use and look after your Ooni Cast Iron, plus handy tips and recipes.





# Say hello to Ooni Cast Iron!

Ooni's versatile Cast Iron Series takes cooking to a whole new level. You can use these versatile pans to grill meats, bake fish, sauté vegetables and so much more.

Cast iron has been a cookware staple for thousands of years. Modern chefs keep cast iron pans on hand because they're durable and can resist very high temperatures. Our high-quality cast iron Sizzler and Grizzler pans are extremely useful and long lasting, and we're confident that you'll love them.

Ooni Cast Iron Series pans work beautifully with Ooni pizza ovens, but you can also use them on your barbecue, over an open fire, on your regular stovetop or in your domestic oven.

Welcome to the world of cast iron cooking:  
you're going to love it.

Thank you,  
**Kristian and the Ooni Team**







<b>en</b>	The cast iron ovenware and steel trivet become very hot. Always allow to cool down before handling.
<b>da</b>	Ovnfaste enheder af støbejern og stålet bliver meget varme. Tillad dem altid at køle af, før du håndterer dem.
<b>de</b>	Das Gusseiserne Ofengeschirr und das Stahlgestell werden sehr heiß. Vor Gebrauch immer abkühlen lassen.
<b>el</b>	Τα σκεύη φούρνου από χυτοσίδηρο και η ατσάλινη βάση θερμαίνονται πολύ. Πάντοτε να τα αφήνετε να κρυώσουν προτού τα αγγίξετε.
<b>es</b>	Los utensilios para horno de hierro fundido y el soporte de acero se calientan mucho. Deja siempre que se enfrien antes de manipularlos.
<b>et</b>	Malmist ahjunõud ja terasest alus muutuvad väga kuumaks. Enne käsitemist laske neil alati jahtuda.
<b>fi</b>	Valurautaiset uunivuoat ja terästeline kuumenevat rajusti. Anna niiden jäähtyä aina ennen käsittelyä.
<b>fr</b>	Les ustensiles en fonte et le support en acier atteignent une température très élevée. Laissez-les toujours refroidir avant de les manipuler.
<b>fr-ca</b>	Les accessoires de cuisson en fonte et le support en acier deviennent très chauds. Laissez-les toujours refroidir avant de les manipuler.
<b>he</b>	כלי התנור העשויים מברזל יצוק וכן מעמד הפלדה מתחממים מאוד. תמיד יש לוודא שהם התקררו לפני שתגעו בהם.
<b>hr</b>	Tijelo pećnice od lijevanog željeza i čelični stalak se veoma zagrijavaju. Uvijek ih ostavite da se ohlade prije nego što počnete njima rukovati.
<b>hu</b>	Az öntöttvas sütőedények és acél állvány rendkívül felforrósodnak. Mindig várja meg amíg lehülnek, mielőtt hozzányúlna.
<b>is</b>	Eldfasta steypujárnsilátíð og stálstandurinn verða mjög heit. Leyfðu þeim alltaf að kólna áður en þau eru meðhöndluð.
<b>it</b>	Le stoviglie in ghisa e il supporto in acciaio diventano molto caldi. Lasciali sempre raffreddare prima di maneggiarli.
<b>jp</b>	鑄鉄製オープンウェアとスチール製スタンドは非常に熱くなります。取り扱いの際は常に冷却させてください。
<b>lt</b>	Iš ketaus pagaminti kepimo indai ir plieninis stovas labai įkaista. Visuomet palaukite kol jie atvės, prieš prisiliesdami.
<b>lv</b>	Čuguna krāns daļas un tērauda statīvs ļoti sakarst. Pirms rīkoties ar tiem, vienmēr ļaujiet tiem atdzist.
<b>nl</b>	Het gietijzeren ovengereedschap en de stalen standaard worden erg heet. Laat ze altijd afkoelen voordat ze worden gebruikt.
<b>no</b>	Støpejernet og stålstativet blir svært varme. La dem alltid kjøle seg ned før du håndterer dem.
<b>pl</b>	Żeliwne naczynia i stalowa podstawa bardzo się nagrzewają. Przed dotknięciem ich należy zawsze odczekać, aż ostygną.
<b>pt</b>	Os utensilios de ferro fundido e o suporte de aço ficam muito quentes. Deixe-os sempre arrefecer antes de manusear.
<b>ru</b>	Жаростойкая посуда из чугуна со стальной ручкой разогревается до очень высоких температур. Перед работой с такими изделиями обязательно дайте им остыть.
<b>sl</b>	Litoželezna posoda za uporabo v pećicah in jekleno stojalo se zelo segrejeta. Pred ravnanjem z njima vedno počakajte, da se ohladita.
<b>se</b>	Eldfasta ugnisformar i gjutjärn och stålstativet blir mycket heta. Låt dem alltid svalna innan du hanterar dem.
<b>tr</b>	Dökme demir fırın malzemeleri ve çelik tezgah çok ısınır. İşlem yapmadan önce mutlaka soğumaya bırakın.
<b>zh</b>	铸铁烤盘和钢制支架会变得很热。务必要等待其温度降低后再拿取。



Scan for  
Cast Iron recipes







# Assembly

1

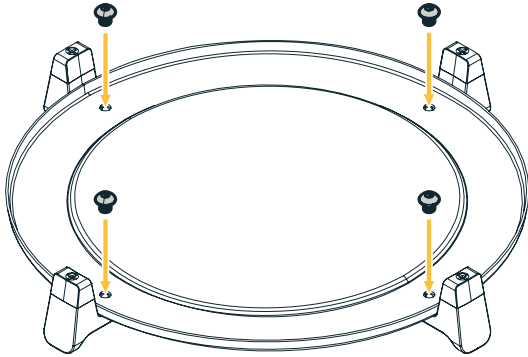

2

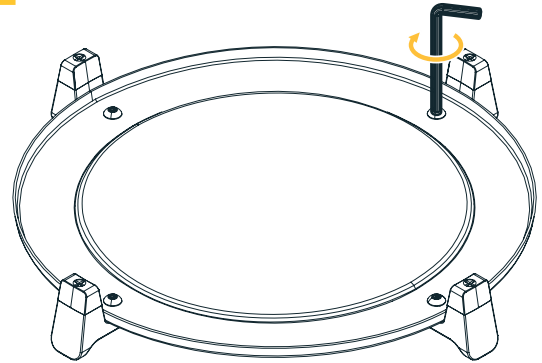

3

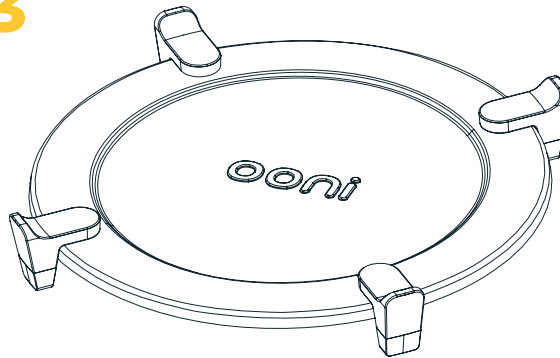

1

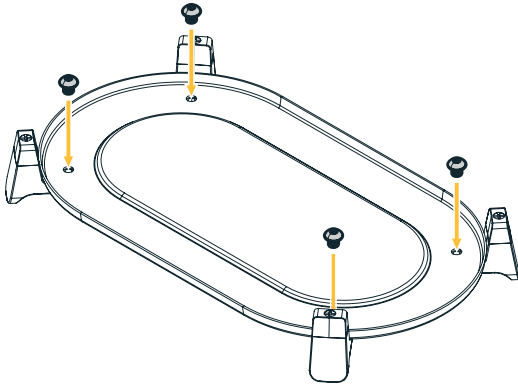

2

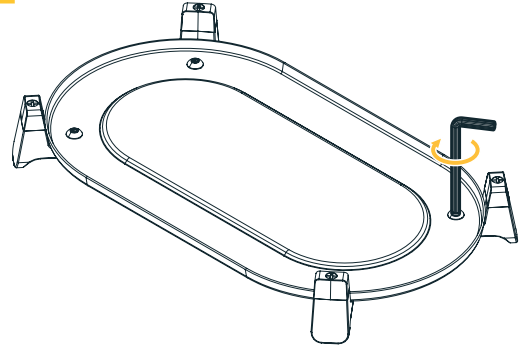

3

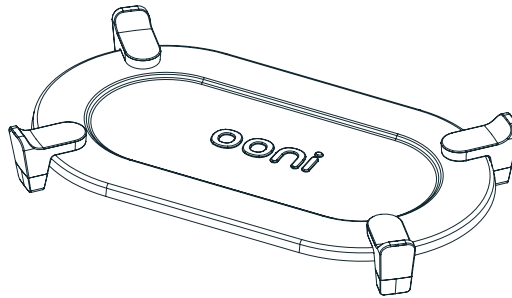



1

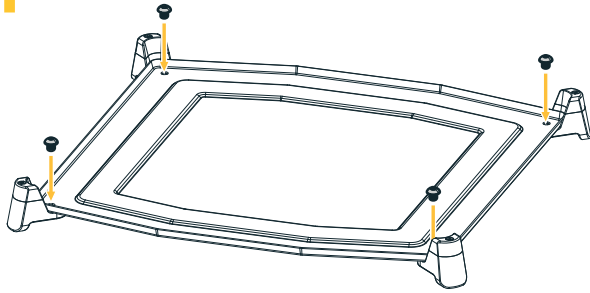

2

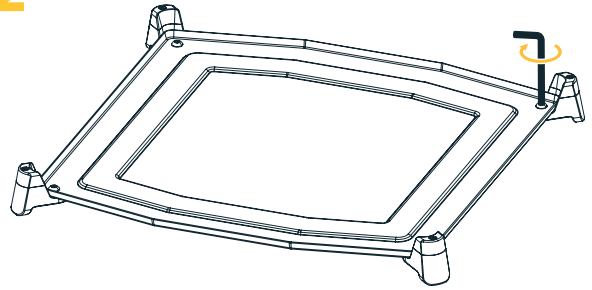

3

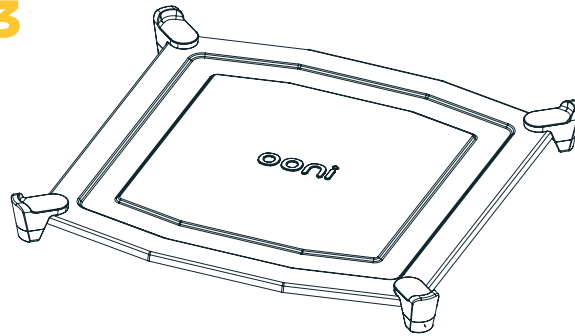

# Seasoning Cast Iron

## Why should you season your cast iron?

Seasoning your cast iron creates a bond between the oil and the surface of your pan, giving your pan a non-stick quality. This process also helps to prevent rust. We recommend that you clean and season your cast iron pan before using it for the first time.

## Before your first cook

1. Hand-wash your cast iron pan with warm, slightly soapy water.
2. Dry thoroughly with a paper towel or a lint-free cloth.
3. Rub a thin layer of oil onto all surfaces, inside and out, using paper towels or a lint-free cloth. For best results, use vegetable, canola or flaxseed oil. The layer of oil should be very light, and should be buffed firmly into the surface until it is almost invisible.
4. Place your cast iron upside down in a preheated oven at 400°F (205°C) for 60 minutes. Place a piece of foil, or a baking sheet or tray underneath to catch any oil drips.  
*Note: Your pan might smoke a little while it seasons. This is normal.*
5. Allow your cast iron to cool in the oven before using it to cook with.

*Note: If your cast iron pan gets dull or sticky, repeat the steps above. We re-season our cast iron every three months.*

 Check out our YouTube channel for a step-by-step video guide on how to season your cast iron.







# Care and Cleaning Instructions

Caring for your cast iron is easy. Follow these steps and your pan will last for generations.

## Clean your cast iron after every cook

1. Don't put a hot cast iron pan straight into cold water, because it could suffer thermal shock and crack.
2. Hand wash your cast iron with warm, slightly soapy water and a sponge or stiff brush.  
*Note: Don't use metal scouring pads or steel wool to clean your cast iron, and never put your pan in a dishwasher, as doing so can remove the seasoning and damage the cast iron surface.*
3. Dry thoroughly with paper towels or a lint-free cloth.
4. Rub a light layer of oil onto all of the cast iron pan's surfaces.
5. Store in a dry environment. Never store when wet.

## Care and maintenance

The more you use your cast iron, the more seasoned it will get. If the surface looks dull after periods without use, or if you find food is sticking to it, re-season following the steps on page 2.

# Troubleshooting

## **My cast iron has a rough surface**

This is normal and is a result of the cast manufacturing process. Over time and through use, the surface will become smoother.

## **My cast iron looks rusty**

Cast iron is tough. If it has been exposed to moisture and is showing some rust spots, these can be removed with a repeat of the seasoning process (page 2) or by washing with household vinegar and a sponge. If the spots persist, soak the area in vinegar for up to 24 hours before scrubbing clean. Remember to give your cast iron plenty of time in the oven at a high temperature.

## **My cast iron is flaking**

Don't worry. Your cast iron isn't ruined — it just needs some care. Flaking can be an indication that excess oil was used during your seasoning. Re-season your cast iron with a very light layer of oil. Remember to give your cast iron time in the oven at a high temperature and to leave it in the oven while it cools.

## **My cast iron is sticky after seasoning**

Using too much oil during seasoning will create a thick, sticky layer. To remove this, wash and re-season with a light layer of oil as per the instructions on page 2.

## **Can I use my cast iron with a conventional oven?**

Your Ooni cast iron will work in a conventional oven and on an electric, gas and induction stovetop. Take care when moving your cast iron pan on an induction hob, as sliding it across the surface may cause scratching. You can also place cast iron directly over an open flame or on a barbecue grill.

## **What can I cook using my cast iron?**

You can cook almost everything and anything in your cast iron and we've included a recipe for you to try. Avoid highly acidic foods until your cast iron is well seasoned. Visit [ooni.com](https://www.ooni.com) for recipes and inspiration.



## DO's and DON'Ts for all cast iron

- ✓ Do treat your cast iron with care. It's tough and can withstand almost anything but the better you treat it, the longer it will last.
- ✓ Do clean and lightly oil your cast iron after every use.
- ✓ Do use your cast iron often.
- ✓ Do enjoy experimenting and creating amazing food with your cast iron.
- ✗ Don't leave your cast iron to soak in water for a long time, or store it while wet.
- ✗ Don't pick up hot cast iron without using the removable handle, protective gloves or a thick, dry towel.
- ✗ Don't place hot cast iron on non-heatproof surfaces.
- ✗ Don't use steel wool or other abrasive products to clean your cast iron.

**ooni.com**

© 2022 Ooni

Ooni is a registered trademark of Ooni Ltd.

All rights reserved.

PA-A00324