

Constant Speed Mixer, Model 686CS

Instruction Manual



Manual No. D00312132, Revision G
Instrument No. 101656308

Constant Speed Mixer, Model 686CS Instruction Manual

©2016 Fann Instrument Company

Houston, Texas, USA

All rights reserved. No part of this work covered by the copyright hereon may be reproduced or copied in any form or by any means (graphic, electronic, or mechanical) without first receiving the written permission of Fann Instrument Company, Houston, Texas, USA.

Printed in USA.

The information contained in this document includes concepts, methods, and apparatus which may be covered by U.S. Patents. Fann Instrument Company reserves the right to make improvements in design, construction, and appearance of our products without prior notice.

FANN[®] and the FANN logo are registered trademarks of Fann Instrument Company in the United States and/or other countries. All other trademarks mentioned in the operating instructions are the exclusive property of the respective manufacturers.

Contact Fann Instrument Company

Phone	1-281-871-4482 1-800-347-0450
Fax	1-281-871-4358
Postal Address	Fann Instrument Company P.O. Box 4350 Houston, Texas, 77210 USA
Shipping Address	Fann Instrument Company 14851 Milner Road, Gate 5 Houston, Texas, 77032, USA
Online	www.fann.com fannmail@fann.com

Table of Contents

1	Introduction.....	6
1.1	Document Conventions	7
2	Safety	8
3	Features and Specifications.....	9
3.1	Mechanical Features	10
3.2	Control Features.....	10
4	Installation	12
5	Operation.....	13
5.1	Key Functions.....	14
5.2	Basic Operating Instructions	15
5.3	Profile Programming Instructions	16
5.4	Preprogrammed Profile.....	18
5.5	USB Remote Control	18
5.6	Basic Mixing Instructions	19
6	Test Analysis	20
7	Troubleshooting and Maintenance	21
8	Accessories	22
9	Parts List.....	23
10	Warranty and Returns.....	24
10.1	Warranty.....	24
10.2	Returns.....	24

List of Figures

Figure 3-1 Constant Speed Mixer, Model 686CS	9
Figure 3-2 Model 686CS Control Panel	11
Figure 5-1 Blade Assembly	13
Figure 5-2 Remote Control	18

List of Tables

Table 3-1 Constant Speed Mixer, Model 686CS Specifications	9
Table 8-1 Optional Accessories for the Model 686CS Mixer	22
Table 9-1 Parts List for the Model 686CS Mixer	23
Table 9-2 Waring Blade Assembly Model 686CS Mixer	23

1 Introduction

The Fann Constant Speed Mixer, Model 686CS is designed to mix cements to comply with American Petroleum Institute (API) specifications and recommended practices.

As deeper wells are being drilled, heavier weight cements are needed to withstand higher downhole pressures. The Model 686CS has a heavy-duty motor that can handle thicker cements at the proper speed. The mixer has control buttons that the operator can use to program the proper mixing speeds and times. One control button, the API Profile button is preprogrammed with the API standard settings, 12,000 rpm for 35 seconds. These programming features save the operator time.

For specification details, refer to the following API documents:

- API Recommended Practice for Testing Well Cements, API RP 10B-2
- API Specification for Cements and Materials for Well Cementing, API Spec 10A

1.1 Document Conventions

The following icons are used as necessary in this instruction manual.

- 

NOTE. Notes emphasize additional information that may be useful to the reader.
- 

CAUTION. Describes a situation or practice that requires operator awareness or action in order to avoid undesirable consequences.
- 

MANDATORY ACTION. Gives directions that, if not observed, could result in loss of data or in damage to equipment.
- 

WARNING! Describes an unsafe condition or practice that if not corrected, could result in personal injury or threat to health.
- 

ELECTRICITY WARNING! Alerts the operator that there is risk of electric shock.
- 

HOT SURFACE! Alerts the operator that there is a hot surface and that there is risk of getting burned if the surface is touched.

2 Safety

This blender is similar to any mixing blender and does not present any unusual hazards.

Follow these recommended safety practices:

1. The operator should always wear safety glasses in case the mixture splatters when adding ingredients.
2. The operator should not drop any foreign objects in the container while mixing is occurring. These foreign objects could strike the operator or damage the mixing blades and container.
3. The Model 686CS should be plugged in to a properly grounded outlet with the ground prong in place.
4. Do not use extension cords.
5. Always remove the plug from the receptacle before performing any work on the mixer base.
6. Do not immerse the mixer in any fluid or spray it with any fluids.
7. The blender should be at a comfortable height for the operator. The operator should be able to add ingredients without straining to reach the mixer. Also, the mixer should be close enough to shut it off quickly if necessary.
8. The mixing cup should be cleaned thoroughly after use to prevent the buildup of cement or other deposits. These deposits can cause accelerated wear of components. The mixing blades should be checked daily for damage. Damaged or worn blades should be replaced immediately.

3 Features and Specifications

This unit is based on a standard, heavy-duty mixing blender manufactured by Waring. It is specially designed to comply with API standards and to allow automatic programming of some mixing procedures. The mixer comes with a remote control for optional use.

Table 3-1 Constant Speed Mixer, Model 686CS Specifications

Category	Specification
Speed Range	1,000 to 28,000 rpm
Container with lid	32 oz (946 mL) stainless steel container
Dimensions (Width x Depth x Height)	11 x 10 x 16 inches 28 x 25 x 41 centimeters
Weight	17 lb (7.7 kg)
Power Supply	120 V, Frequency 50/60 Hz, Current 13 amps



Figure 3-1 Constant Speed Mixer, Model 686CS

3.1 Mechanical Features

The Constant Speed Mixer (CSM) is equipped with a 32 ounce (946 mL) stainless steel jar.

An additional 64 ounce (1.9 liter) stainless steel container is also available and can be ordered separately.



Both stainless steel containers (32 or 64 ounces) fit directly onto the mixer base. Adapters are not required.

3.2 Control Features

The Model 686CS Mixer has a liquid crystal display (LCD) screen that shows the operating messages on a sharp, blue backlight, making it easy to read.

The mixer has programming features that can be set up using these buttons:

- Set Button- for programming profiles and mixer settings
- Profile Buttons – for executing a previously programmed profile
- API Button – to use preprogrammed API standard setting

The mixer also has these control features for easy operation:

- Power on/Off Button
- Start/Stop Button
- Speed Controls
- Time Controls

Figure 3-2 shows the control panel. How to use each key (button) is explained in section 5.1.

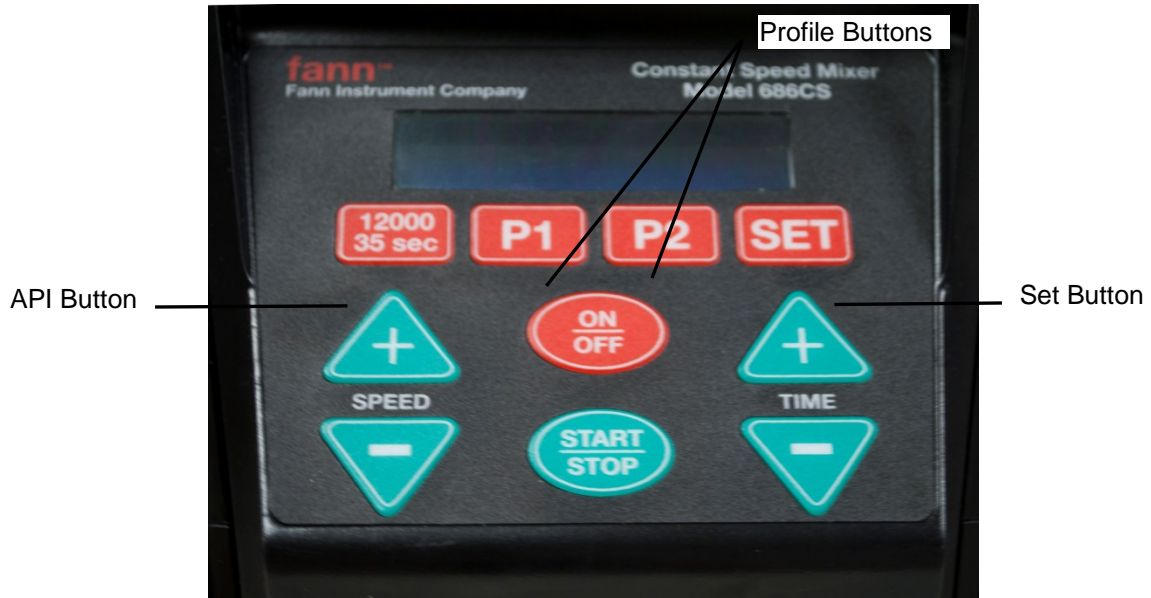

Figure 3-2 Model 686CS Control Panel

4 Installation

The mixer should be placed on a countertop at a suitable height for the operator to add ingredients. The operator should be able to easily reach the control panel and view the display.



This mixer requires 120 VAC, 50-60 Hz. If the power source is 240 VAC, a step down transformer (Part Number 101553700) must be used and ordered separately.

5 Operation



Always install the mixing blades so that the blade tips curve outward and the beveled edges are down. See Figure 5-1 below, and refer to Table 9-2 for a list of part numbers and descriptions.

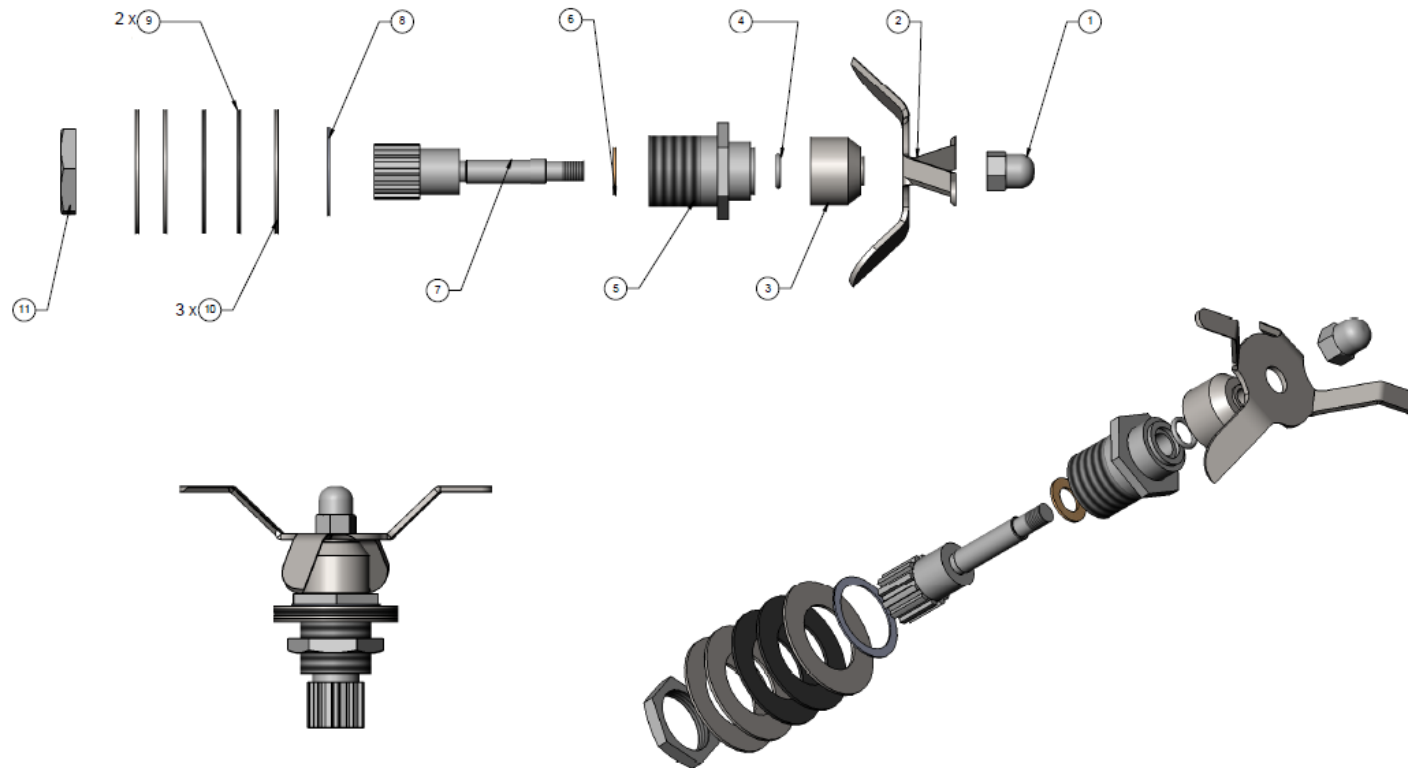

Figure 5-1 Blade Assembly

5.1 Key Functions



Do NOT operate this mixer empty or without the container or mixing cup.



Power On/Off Button — Press this button to turn the mixer on and off. When the unit is turned on, the blue LCD backlight will illuminate and the machine is ready for operating. To turn off the machine, press and hold this button three seconds or more.



Start/Stop Button — Press this button once and the machine will start mixing. Press this button again and the machine will stop.



Speed Controls — Each press increases or decreases the set mixing speed in 100 rpm increments. The speed range for this mixer is 1000 to 28,000 rpm.



Time Controls — Gradually increase and decrease timing in seconds (sec) increment. The maximum time setting is 240 seconds. A setting of 999 seconds means that the machine will run at set speed continuously until user stops it.



Set Button — This button is used for programming profiles and machine settings.



Profile Buttons — Pressing any of these buttons will start the mixing and execute a previously programmed profile.



API Button — This button is preprogrammed with API standard settings, 12,000 rpm and 35 sec. These settings cannot be changed by the user.

5.2 Basic Operating Instructions

1. Plug the power cord into an AC outlet. Press the **ON/OFF** button to turn the unit **ON**. The blue LCD backlight will turn on and the words, **FANN Instrument Model 686CS** will appear, indicating that the power is **ON**. After a few seconds, the machine enters the operational mode.



The default **SPEED** (RPM) and **TIME** settings are the last values when the machine was turned off.

2. The motor speed can be adjusted by pressing **UP (+)** and **DOWN (-) SPEED** buttons.
3. The run time can be adjusted by pressing **UP (+)** and **DOWN (-) TIME** buttons. A value of zero (0) indicates the machine will mix indefinitely until the user manually stops the mixing.
4. Press the **START/STOP** button to run the mixer. The LCD will display the motor's rpm and time remaining. The machine does not start counting time until the set speed is reached. To stop mixing operation, press the **START/STOP** button.



Pressing the **SPEED UP (+)** or **DOWN (-)** buttons while mixer is running will change the speed to a new value, but will not change the timer.

5.3 Profile Programming Instructions

There are two programmable profiles for easy operation and consistent results. Each profile can be programmed with five different speeds, running times, and acceleration.

For example, the Profile 1 (P1) can be set as follows:

Profile 1 (P1)

- Step 1: RPM 4000, TIME 15 sec, ACCEL 2000
- Step 2: RPM 6000, TIME 20 sec, ACCEL 5000
- Step 3: RPM 8000, TIME 25 sec, ACCEL 0
- Step 4: RPM 10000, TIME 30 sec, ACCEL 0
- Step 5: RPM 12000, TIME 35 sec, ACCEL 12,000

The acceleration setting determines how quickly the mixer reaches the desired speed. The lower the acceleration setting, the longer it will take to reach the desired speed.

Acceleration values can be changed from 500 to 20,000 rpm/sec.

Setting a value of 1000 rpm means the mixer will ramp up to the desired speed at a rate of 1000 rpm/sec.

The minimum acceleration is 500 rpm/sec and the maximum acceleration is 20,000 rpm/sec.

Setting the acceleration value to 0 will apply these default acceleration (ACCEL) values:

Acceleration Settings

- ACCEL = 3000 rpm/sec, when SPEED = 1000-5000 rpm
- ACCEL = 7000 rpm/sec, when SPEED = 5000-9000 rpm
- ACCEL = 10,000 rpm/sec, when SPEED = 9000-14,000 rpm
- ACCEL = 12,000 rpm/sec, when SPEED = 14,000-28,000 rpm

To program a profile, follow these instructions:

1. Press **SET**.
2. Select **P1** or **P2** depending on which profile needs to be programmed or press **SET** to exit.
3. In profile editing mode, the top right corner of the display will show the step number – S1, S2, etc. When display reads, “**SET RPM,**” press the **TIME +/-** keys to set value for the current parameter.
4. Next, press the **SPEED +/-** keys to go to the next parameter in this step.
5. When display reads, “**SET TIME,**” press the **TIME +/-** keys to set the time.
6. Press the **SPEED +/-** keys to go to the next parameter.
7. When the display reads, “**SET ACCEL,**” press the **TIME +/-** keys to set the value.
8. Press the **SPEED +/-** keys to go to the next step.
9. Repeat instructions 3-8 to set values for parameters in the next step.



If any step has speed value equal to zero (0), it becomes the last step of the profile.



When editing profiles, use the **SPEED +/-** keys to move between steps and parameters of the step.



When editing profiles, use the **TIME +/-** keys to set the values of the parameters in each step.

5.4 Preprogrammed Profile

To run any of the preprogrammed profiles, press a desired profile button to start the machine. The motor will run at the preset speed within the preset mixing time. The LCD will show the time remaining. Once the mixer counts down to zero (0), the machine will proceed to the next step. If the time for the last step was not specified, the mixer will continuously run until the **START/STOP** button is pressed.

5.5 USB Remote Control



The remote control is powered through the USB port on the mixer.

Plug the remote control into the mixer using the USB-B cable supplied with the unit. The remote control LCD display should then be visible.

The remote control buttons are shown in Figure 5-2. The user must select **SPEED** followed by either the + or – buttons to adjust the mixing speed. Likewise, to adjust the mixing time, the user must select **TIME** followed by either the + or – buttons.



Figure 5-2 Remote Control

5.6 Basic Mixing Instructions



The blender should not be operated without any contents in the mixing cup.



Always install the mixing blades so that the blade tips curve upward and the beveled edges are visible. See Figure 5-1.

To mix cement slurry in the Constant Speed Mixer, follow these steps:

1. Fill the 32-oz or 64-oz container to the proper level with fluid.
2. Weigh and prepare the dry constituents. Place these additives where they can be quickly added during the mixing phase.
3. Press **P1** on the control panel and watch the display for speed.
4. When the speed reaches 4000 RPM, quickly add the dry ingredients as described in the API specification. The mixer will begin counting down to 15 seconds when the 4000 RPM speed is achieved.
5. After the 15-second mixing step is complete, press the button labeled **12000 35 sec**. The mixer will accelerate to 12,000 RPM. When the speed stabilizes at 12,000 RPM, the blender will count up to 35 seconds. The mixer will then slow down and stop. Do not remove the mixer container until the display shows 0 RPM and the fluid stops swirling. The cement sample is now ready for testing.

If you are experimenting with additives that are harder to mix, you can manually operate the blender at any speed and time setting before pressing the API button. If alternate speeds are desired, they can be programmed into profiles **P1** and **P2**.

6 Test Analysis

The Constant Speed Mixer produces no results to be analyzed.

This mixer complies with API Spec 10A, Cements and Materials for Well Cementing and API RP 10B-2, Recommended Practice for Testing Well Cements.

7 Troubleshooting and Maintenance

The Constant Speed Mixer, Model 686CS is a heavy-duty machine that requires minimal daily maintenance.



Before using the mixing blades, weigh them and record the weight. Replace blades when the weight changes by 10%. See API Specification 10A, Specification for Cements and Materials for Well Cementing, section 7 on mixing devices.



Always install the mixing blades so that the blade tips curve upward and the beveled edges are visible. See Figure 5-1.

Here are a few tips for caring for the Model 686CS:

- The mixing container should be washed thoroughly after each batch to remove deposits that can cause wear.
- Check the blades in the mixing container daily for wear.
- Replace blades when they have lost 10% mass.
- Ensure that the blades turn freely in the container. If the blades drag, inspect the area around them for deposits or other material. If this problem cannot be readily fixed, replace the container.
- If the controller does not respond to changes from the control pad, unplug the mixer from the power source to reset it.
- The motor and controller do not have any user-repairable items. If the motor fails to start or does not maintain speed properly, return the blender to Fann for repair.
- If the display or programming buttons stop working properly, return the unit to Fann for repair.

8 Accessories

Table 8-1 Optional Accessories for the Model 686CS Mixer

Part Number	Description
101553700	Transformer, Step Up/Down, 120 V TO 240 V, 3000 W
101948589	Stainless Steel container, 64 oz (1.9 L)
101998395	Blending Assembly for 64 oz (1.9 L) container
102001793	Blender Blade for 64 oz (1.9 L) container

9 Parts List

Table 9-1 Parts List for the Model 686CS Mixer

Part Number	Description
101948588	Stainless Steel container, 32 oz (946 mL)
101957727	Blending Assembly for 32 oz (946 mL) container (includes blender blade)
102001777	Blender Blade for 32 oz (946 mL) container
102083685	Remote Control Panel
D00312132	Instruction Manual

Table 9-2 Waring Blade Assembly Model 686CS Mixer

Part Number	Description
100047698	Washer, thrust
101015529	Nut cap, Waring
102001777	Blender blade, 32oz/.95 liters jar
102043198	Washer, Nylon
102043666	Washer, SS Waring
102043686	Nut hex, Waring
102190547	Bearing holder w/ O-ring groove
204626	O-ring 1/4 x 3/8
205072	Gasket 1.25 x 0.74 x 1/6
D00661143	Bearing cap
D00661144	Shaft for blade assembly

10 Warranty and Returns

10.1 Warranty

Fann Instrument Company warrants only title to the equipment, products and materials supplied and that the same are free from defects in workmanship and materials for one year from date of delivery. **THERE ARE NO WARRANTIES, EXPRESS OR IMPLIED OF MERCHANTABILITY, FITNESS OR OTHERWISE BEYOND THOSE STATED IN THE IMMEDIATELY PRECEDING SENTENCE.** Fann's sole liability and Customer's exclusive remedy in any cause of action (whether in contract, tort, breach of warranty or otherwise) arising out of the sale, lease or use of any equipment, products or materials is expressly limited to the replacement of such on their return to Fann or, at Fann's option, to the allowance to Customer of credit for the cost of such items. In no event shall Fann be liable for special, incidental, indirect, consequential or punitive damages. Notwithstanding any specification or description in its catalogs, literature or brochures of materials used in the manufacture of its products, Fann reserves the right to substitute other materials without notice. Fann does not warrant in any way equipment, products, and material not manufactured by Fann, and such will be sold only with the warranties, if any, that are given by the manufacturer thereof. Fann will only pass through to Customer the warranty granted to it by the manufacturer of such items.

10.2 Returns

For your protection, items being returned must be carefully packed to prevent damage in shipment and insured against possible damage or loss. Fann will not be responsible for damage resulting from careless or insufficient packing.

Before returning items for any reason, authorization must be obtained from Fann Instrument Company. When applying for authorization, please include information regarding the reason the items are to be returned.

Our correspondence address:

Fann Instrument Company
P.O. Box 4350
Houston, Texas USA 77210

Telephone: 281-871-4482

Toll Free: 800-347-0450

FAX: 281-871-4446

Email fanmail@fann.com

Our shipping address:

Fann Instrument Company
14851 Milner Road, Gate 5
Houston, Texas USA 77032