

Model 165AT Atmospheric Consistometer

Instruction Manual



Manual No. 101443559, Revision B

Instrument No. 359571 & 359572

Model 165AT Atmospheric Consistometer Instruction Manual

©2013 Fann Instrument Company

Houston, Texas, USA

All rights reserved. No part of this work covered by the copyright hereon may be reproduced or copied in any form or by any means (graphic, electronic, or mechanical) without first receiving the written permission of Fann Instrument Company, Houston, Texas, USA.

Printed in USA.

The information contained in this document includes concepts, methods, and apparatus which may be covered by U.S. Patents. Fann Instrument Company reserves the right to make improvements in design, construction, and appearance of our products without prior notice.

FANN[®] and the FANN logo are registered trademarks of Fann Instrument Company in the United States and/or other countries. All other trademarks mentioned in the operating instructions are the exclusive property of the respective manufacturers.

Contact FANN



Phone

TELEPHONE: 281-871-4482
TOLL FREE: 800-347-0450
FAX: 281-871-4358



Mail

Fann Instrument Company
P.O. Box 4350
Houston, Texas, 77210 USA



Location

Fann Instrument Company
14851 Milner Road, Gate 5
Houston, Texas, 77032, USA



Online

www.fann.com
fannmail@fann.com

Table of Contents

1	Introduction.....	5
1.1	Document Conventions	5
2	Safety	7
2.1	Safe Heating.....	7
2.2	Safe Electrical Operation	7
2.3	Ergonomic Considerations.....	7
2.4	Environmental Considerations	8
3	Features and Specifications.....	9
3.1	Mechanical Components	11
3.2	Electrical Components.....	12
4	Installation	13
4.1	Instrument Placing.....	13
4.2	Plumbing Connections.....	13
4.3	Electrical Connections	13
5	Operation.....	14
5.1	Calibration	14
5.2	Prepare the Atmospheric Consistometer	15
5.3	Prepare the Slurry.....	15
5.4	Heat and Stir the Slurry	15
5.5	Stop Heating and Stirring the Slurry.....	16
5.6	Cleaning the Slurry Cup and Paddle.....	16
6	Test Analysis	17
7	Troubleshooting and Maintenance.....	18
7.1	Troubleshooting Tips	18
7.2	General Maintenance	19
7.3	Rotator Bearing Maintenance	20
8	Accessories	21
9	Parts List.....	22
10	Warranty and Returns.....	28
10.1	Warranty.....	28
10.2	Returns.....	28

List of Figures

Figure 3-1 Model 165AT Atmospheric Consistometer	10
Figure 9-1 Atmospheric Consistometer, Front View.....	24
Figure 9-2 Atmospheric Consistometer, Side View.....	25
Figure 9-3 Wiring Diagram	26
Figure 9-4 Lid Assembly.....	27

List of Tables

Table 3-1 Model 165AT Atmospheric Consistometer Specifications.....	10
Table 7-1 Troubleshooting Guide	18
Table 8-1 Accessories.....	21
Table 9-1 Model 165AT Parts List	22
Table 9-2 Lid Assembly, P/N 101430927	27

1 Introduction

The Model 165AT Atmospheric Consistometer performs basic consistency measurements on cement slurry samples and conditions (or shears) under elevated temperatures, 200°F (93°C) maximum, at atmospheric pressure.

This instrument is designed to conform to API Specification 10A, Specification for Cements and Materials for Well Cementing, and API Recommended Practice 10B-2, recommended Practice for Testing Well Cements.

The Model 165AT conditions cement slurry for free fluid (free water), static fluid loss, and other tests.

1.1 Document Conventions

The following icons are used as necessary in this instruction manual.



NOTE. Notes emphasize additional information that may be useful to the reader.



CAUTION. Describes a situation or practice that requires operator awareness or action in order to avoid undesirable consequences.



MANDATORY ACTION. Gives directions that, if not observed, could result in loss of data or in damage to equipment.



WARNING! Describes an unsafe condition or practice that if not corrected, could result in personal injury or threat to health.



ELECTRICITY WARNING! Alerts the operator that there is risk of electric shock.



HOT SURFACE! Alerts the operator that there is a hot surface and that there is risk of getting burned if the surface is touched.



EXPLOSION RISK! Alerts the operator that there is risk of explosion.

2 Safety

Safe laboratory practices and procedures should be observed while operating and maintaining the Model 165AT. This section lists some precautions to follow.

2.1 Safe Heating

The fluid (water or mineral oil) in the stainless steel tank is directly heated by 1500 watt heating element inside the tank. The maximum temperature is 200°F (93°C).



The tank surfaces are a potential burn hazard.

2.2 Safe Electrical Operation

The power source for the Model 165AT is either 115V or 230V alternating current. Refer to the electrical schematic (Section 9) before performing maintenance or troubleshooting.



Disconnect the power from the unit before performing electrical or mechanical maintenance.



When the power switch is turned off, there are hot electrical terminals inside the instrument (rear).

2.3 Ergonomic Considerations

Without cement slurry and heating fluid, the Model 165AT Atmospheric Consistometer weighs 35 pounds (16 kg). Three gallons of water adds 25 pounds (11.3 kg) and three gallons of white mineral oil adds 22 pounds (10 kg). The tank should be drained before moving the instrument.

2.4 Environmental Considerations

This instrument test cement slurries containing additives and it uses water or white mineral oil as thermal transfer fluid. These fluids may vaporize when the instrument is operating near the maximum temperature.

Follow proper handling and disposal practices for these materials.

3 Features and Specifications

The Model 165AT Atmospheric Consistometer measures consistency and temperature of cement slurries. This instrument is also specifically designed to prepare cement slurries for the testing various parameters, such as thickening time, free water content, viscosity, rheological properties, and fluid loss.

The following options are available:

- Part Number 359571 — 115V, 50/60 Hz
- Part Number 359572 — 230V, 50/60 Hz

The Model 165AT features these components:

- Stainless steel water bath with programmable temperature control to set temperature rise in accordance with API Spec 10
- Microprocessor-based temperature controller and digital temperature indicator for accurate temperature control
- Impeller-stirred water bath for temperature stability
- Direct torque spring readout for instant slurry consistency in Bearden units (Bc)
- Toothed belt drive for precise rotation at 150 rpm
- Internal cooling coils to cool the slurry below room temperature

See Figure 3-1. Refer to Table 3-1 for specifications.

Table 3-1 Model 165AT Atmospheric Consistometer Specifications

Category	Specification
Temperature Range	Ambient to 200°F (93°C)
Pressure Range	Atmospheric pressure only
Consistency Range	0 to 100 Bearden (Bc)
Slurry Cup Stirring Speed	150 rpm ± 15 rpm
Heater	1500 W
Cup Volume	470 ml
Dimensions (Width x Depth x Height)	25 x 15.5 x 18 inches 64 x 39 x 45 centimeters
Weight	80 lb (50 kg)
Electrical	115 VAC, Single Phase, 14A, 50/60 Hz
	230 VAC, Single Phase, 7A, 50/60 Hz
Cooling Water	100 psi (6.8 bar) maximum, 1/4 -in. Female, NPT



Figure 3-1 Model 165AT Atmospheric Consistometer

3.1 Mechanical Components

Refer to Figure 3-1.

3.1.1 Tank

The stainless steel tank holds the heating bath, heating element, cooling coil, non-rotating fluid agitator paddle, and fluid thermocouple. The thermocouple, temperature controller, and heater maintain the desired temperature of the bath throughout a test.

3.1.2 Heater

The fluid in the tank is directly heated by a 1,500 watt tubular heater.

3.1.3 Cooling Coil

The cooling coil quickly reduces the temperature of the bath. It is accessed through two 1/4 NPT female fittings located on the upper right side of the tank.

3.1.4 Slurry Cup Drive

Through an electronic motor drive controller, a DC electric motor, timing belt and pulleys turn the slurry cup drive sleeves. The drive sleeves ride in non-sealed roller bearings attached to the tank cover.

3.1.5 Slurry Cup

Two brass slurry cups (containers), which may be disassembled for easy cleaning, are included. These contain a non-rotating paddle which is used with the indicator lid to show the slurry consistency.

3.1.6 Indicator Lid

The slurry cup closure (lid assembly) includes a torsion spring, scale and pointer. This lid engages the slurry cup paddle. When the slurry cups are turning, the slurry consistency is indicated on the lid in Bearden units (Bc), where $7 = 70 \text{ Bc}$.

3.1.7 Shear Pin

A shear pin in the lid stop ensures that slurry samples that become abnormally viscous do not damage the Consistometer. When the level of stress on the Consistometer's drive becomes excessive, the shear pin breaks and relieves the stress on the drive.

3.2 Electrical Components

3.2.1 Power Inlet

A universal IEC-320 type power inlet in the rear permits a wide variety of power cords to easily be used with the consistometer. An unterminated power cord of the correct gauge wire is provided.

3.2.2 Electrical Fuses

To protect the instrument, within the cabinet, the power leads connect directly to fuses before other circuits. The motor controller circuit board is also fused.

3.2.3 Drive Motor & Controller

The 115V consistometers use a 90VDC drive motor and a 115V motor controller to maintain a slurry cup speed of 150 RPM.

The 230V consistometers use a 180VDC drive motor and a 230V motor controller to maintain a slurry cup speed of 150 RPM.

3.2.4 Control Switches & Relays

The three front panel switches labeled POWER, MOTOR, and HEATER control the corresponding consistometer electrical circuits and illuminate when in the ON position. See Figure 3-1. These switches function as follows:

- POWER switch enables the line voltage to be connected to the two solid state power relays.
- MOTOR switch enables the power to the electronic motor control board.
- HEATER switch enables the line voltage to be connected to one of the two solid state heater relays. When the second relay is closed by the temperature controller, voltage is applied to the heater.

3.2.5 Temperature Controller

An electronic temperature controller senses the bath temperature through a thermocouple in the bath fluid (oil or water). Based on the desired temperature (set point) and the bath temperature, heater voltage may be applied to the heater to increase the bath temperature. The temperature controller displays the bath temperature when the power switch is turned on.

4 Installation

Verify that the shipment includes the instrument and spare parts and that these items are in good condition. Contact Fann Instrument Company if anything is missing or damaged.

4.1 Instrument Placing



An 8BC or larger fire extinguisher to fight electrical and oil fires should be available within 50 feet of the consistometer.

Place the instrument on a firm level surface at the appropriate height for persons using the instrument.

4.2 Plumbing Connections

After the instrument has been placed in the desired location, cooling water, overflow/drain, and electrical connections can be made. The overflow/drain connection is a 1/4-inch tube fitting located on the lower rear of the instrument. The cooling water inlet and outlet are located on the upper right side of the instrument. Using the cooling coils is optional. These connections are 1/4-inch female NPT. The drain and cooling water connections may be made with either metal or plastic tubing.

4.3 Electrical Connections

Electrical connections are made using the three pronged receptacle on the rear of the instrument. An electrical cord is supplied with the instrument.

Wiring should be done by a qualified installer in accordance with local electrical codes.



This instrument should be securely connected to a separate ground earth. The ground wire diameter must be larger than the supply conductors. A 10 gauge minimum ground wire is recommended.

5 Operation

5.1 Calibration



A calibrator (P/N 101402595) is not furnished with the Model 165AT Atmospheric Consistometer. Contact Fann Instrument Company to order it.

The lid and thermocouple circuit should be recalibrated on a regular basis. The recommendations for calibrating are as follows:

- Check the thermocouple calibration at least annually and when a new thermocouple is installed.
- Recalibrate the lid every time the spring is adjusted or replaced.
- Calibrate the temperature using a digital temperature calibrator and a millivolt source.

The lid should be calibrated by using the potentiometer mechanism calibrator (P/N 101402595). This device applies a known torque to the lid spring, allowing the readout to be observed on the lid dial. Calibration of the lid is described below.

1. Set the calibrator near the front edge of a desk or table.
2. Place the lid on the calibrator.
3. Wind the cord clockwise around the lid frame and over the pulley on the calibrator. Place the hanger weight hook in the loop on the end of the cord.
4. Attach a total weight (hanger plus weights) of 300g on the weight hanger. The pointer should read approximately 7.4 (74 Bc).
5. If the pointer indicates a consistency greater than 74 Bc, loosen the set screw holding the spring in place and move it to the right.



By applying additional weights between 0g and 400g and plotting consistency as a function of applied weight, the linearity of the lid may be assessed.

5.2 Prepare the Atmospheric Consistometer

1. Fill the tank with mineral oil (or water) if using it for the first time. The tank holds approximately 3 gallons (15 liters).



If water is used, distilled water is recommended to reduce corrosion. Because the water will evaporate over time, check the water level in the tank at least every 4 hours. The rate of water evaporation is directly proportional to the temperature; it will be greater at higher temperatures.

2. Install the bottom into the slurry cup. Apply a light coating of grease to the O-ring in the slurry cup bottom prior to installation.
3. Install the paddle and slurry cup lid and check to see that the paddle does not rub the slurry cup when the slurry cup turns.
4. The water bath may be pre-heated by following steps in Section 5.4.

5.3 Prepare the Slurry

1. Prepare the slurry in accordance with API Specification 10.
2. Place a paddle into the slurry cup with the point centered in the bottom.
3. Fill the slurry cup to the scribed line.
4. Place the slurry cup lid over the paddle shaft and onto the slurry cup. Engage the lid pins with the slots in the slurry cup, and rotate by hand until the pins stop and the lid is secured to the cup.
5. Place the slurry cup(s) inside the rotators and lower them into the tank. The large pin on the slurry cup lid should contact the stop anchor.

5.4 Heat and Stir the Slurry

1. Turn the POWER switch to the ON position.
2. Turn the MOTOR switch to the ON position.
3. Turn the HEATER switch to the ON position.
4. Set the temperature controller to the desired temperature. Use the up and down arrow buttons on the temperature controller to select the desired temperature set

point. The red (upper) value is the actual temperature, and the green (lower) value is the set point.

5. If the cooling coil is used, turn off the water supply while heating.

5.5 Stop Heating and Stirring the Slurry



Water or oil on the outside of the slurry cup may be very hot, possibly causing thermal burns to skin. When handling the slurry cup immediately after a test, use an insulated barrier between skin and the hot slurry cup.

1. Turn the HEATER switch to the OFF position. If additional slurries will be immediately conditioned at the same temperature, the heater switch may be left in the ON position for up to 1 hour.
2. Turn the MOTOR switch to the OFF position.
3. Remove the slurry cup by lifting on the lid to remove the lid, paddle, slurry cup, and the slurry contained in the slurry cup. Carefully wipe water or oil from the outside of the slurry cup.
4. Process the conditioned slurry as required.
5. If desired, turn on the water supply to the cooling coil.

5.6 Cleaning the Slurry Cup and Paddle

1. Wipe all cement and grease from the slurry cup, lid, and paddle.
2. Remove cement using a metal spatula or wire brush.
3. Remove any cement film by dipping the part in 15% to 20% hydrochloric acid. Let the parts sit for several minutes, and then brush clean and rinse the parts thoroughly with water. Properly dispose the waste acid.
4. Remove grease film with a solvent.
5. Carefully dry the parts.
6. Inspect the parts for damage, and replace those which are damaged.

6 Test Analysis

The Model 165AT Atmospheric Consistometer prepares cement slurry specimens for testing by other instruments and/or methods.

The slurry cup lid has direct torque spring readout. The value is shown on the lid. The readout must be multiplied by 10 to obtain the consistency in Bearden units (Bc).

This instrument conforms to these API standards:

- API Recommended Practice for Testing Field Cements, API RP 10B-2
- API Specification 10A, Specifications for Cements and Material for Well Cementing

7 Troubleshooting and Maintenance

Troubleshooting and regular maintenance procedures are described in this section. If extensive maintenance or service of the instrument is required, please contact Fann Instrument Company.



Only qualified personnel specifically trained in repairing the Model 165 At Atmospheric Consistometer should attempt electrical repairs.

7.1 Troubleshooting Tips

Table 7-1 Troubleshooting Guide

Problem or Symptom	Possible Cause	Corrective Action
Motor speed not correct	The motor control board speed controller is out of adjustment.	Use an optical tachometer to verify the speed. Adjust the motor control speed potentiometer located on the electrical panel outside the cabinet until the slurry cups rotate at the correct speed (API Spec 10: 150 ±15 RPM).
Motor will not operate	Rotator bearings have locked up.	Lubricate/replace rotator bearings.
	Bad speed adjustment potentiometer.	Replace potentiometer.
	Faulty MOTOR switch.	Replace switch
	Loose connection in motor wiring.	Check wiring and repair any loose connections.
	Blown fuse on motor control board.	Check fuses on motor control board and replace if blown.
	Faulty motor control board.	Replace board.
	Faulty motor.	Replace motor.
MOTOR, HEATER, or POWER switches will not stay in the ON position	Short circuit in motor, heater or power circuit.	Locate problem and correct.
	Faulty switch.	Replace switch.

Problem or Symptom	Possible Cause	Corrective Action
Heater does not get hot.	Loose connection in heater circuit.	Repair loose connection.
	Faulty solid state relay.	Check solid state relay and replace if faulty.
	Faulty heater.	Replace heater.
Agitator paddle rubs the tank wall	Excessive play in agitator shaft.	Replace agitator shaft bushings.
Temperature controller displays - - - - in the lower display.	Open circuit in thermocouple circuit.	Locate open circuit and repair.
	Faulty thermocouple.	Replace thermocouple.
Rotator will not turn or is noisy.	Dry or contaminated bronze bearings on rotator.	Clean bearings and coat with light grease.
Noisy slurry cup assembly.	Bent paddle or paddle shaft.	Straighten paddle and/or shaft.

7.2 General Maintenance

This section helps the user solve problems that can be fixed easily and recognize problems that require outside assistance.

If further assistance is needed, contact Fann Instrument Company.

- If the oil or water in the tank becomes dirty or contaminated with cement, drain the tank and clean it.
- Thoroughly clean the slurry cup and paddle after each use to remove all traces of cement.
- Lubricate the O-ring in the slurry cup base with grease before each use.
- Bronze rotator bearing should be periodically coated with a light oil, particularly if water has been used to heat the slurry.
- Check the bushings that hold the water agitator periodically. If bushings become worn excessively replace them.
- Check the timing belt periodically for signs of wear. Replace if necessary.

7.3 Rotator Bearing Maintenance

The rotators are supported by ball bearings which have a low coefficient of friction. The bearings are designed to wear out periodically without causing damage to the more expensive bearing housing and rotator. To extend the life of the bearings, they may be lubricated periodically with light oil. Lubricating the bearings is probably not necessary if mineral oil is used in the heating tank. Follow the steps below when replacing the bearings.

The rotator also uses bronze bearings to support the radial load on the rotator. Residue from water or cement slurry can sometimes cause the bearings to seize or become noisy. They should be lubricated periodically with light oil. Lubricating them is probably not necessary if mineral oil is used in the tank. Using mineral oil as the heating medium usually assures that the bearings are adequately lubricated.

To replace bearings, follow these steps:

1. Disconnect the unit from electrical power.
2. Loosen the bolts holding the motor in place and slide the motor forward.
3. Remove the timing belt from the motor sprocket.
4. Remove the stainless steel tank cover and attached rotators.
5. Remove the 4 screws holding the rotator assembly to the tank cover and remove the tank cover.
6. Pull the rotator up and off to expose the bearings. Lubricate or replace as necessary.
7. Reassemble.
8. Make certain that the timing belt is not too tight. The belt should have approximately 1/2 inch (12.7 mm) slack. If the belt is too tight, the bearings and bushings will fail prematurely.

8 Accessories

Table 8-1 Accessories

Part Number	Description
101402595	Lid Calibration Kit

9 Parts List

The Model 165AT is available in these options:

- Part Number 359571 — 115V, 50/60 Hz
- Part Number 359572 — 230V, 50/60 Hz

For Table 9-1 refer to Figure 9-1, 9-2, and 9-3. For Table 9-2 Lid Assembly, see Figure 9-4.

Table 9-1 Model 165AT Parts List

Item No.	Part No.	Quantity	Description
1	–	1	Tank
3	–	2	Bearing Housing
4	–	2	Rotator
5	101430929	2	Snap Ring, Slurry Cup Base
7	101430924	2	Sleeve, Slurry Cup
8	101950870	1	Heater (115 VAC)
8	101960408	1	Heater (230 VAC)
9	101597391	1	Agitator Support Bushing
10	–	1	Agitator
11	363539	2	Bearing, Ball, 125 x 80 x 22mm
12	–	2	Rotator Sprocket
13	101823795	1	Motor (115 V)
13	101823794	1	Motor (240 V)
14	–	1	Motor Sprocket
15	101597387	2	O-ring, Slurry Cup Base
18	101430927	2	Lid Assembly, Complete
19	–	2	Stop Anchor Assembly (non-rec)
20	101430928	2	Base, Slurry Cup
21	101430913	2	Paddle
21a	102073905	1	Shaft Replacement, Paddle
21b	102074780	1	Pin Replacement, Paddle
21c	102074805	1	Paddle Replacement
22	101401997	1	Timing Belt
23	101597389	2	Shear Pin
24	102164541	1	Thermocouple
101	101443560	1	Controller, Temperature
102	101473130	1	Fuse Holder
102	204128	2	Fuse, 10A (230 V)
102	101473128	2	Fuse, 20A (115 V)
103	101597401	1	Fuse, 25A
104	101243141	1	Fuse, 2A
105	101807666	1	Motor Control Board (115 V)

Item No.	Part No.	Quantity	Description
105	101807666	1	Motor Control Board (240 V)
106	–	1	Power Inlet
107	101473126	3	Solid State Relay, 25A, AC control
108	–	1	Solid State Relay, 25A, DC control
109	102119288	3	Switch, 20A, Breaker
–	101497391	1	Bushing, Impeller
–	–	1	Assy, Idler Pulley Support
–	–	1	Cooling Coil
–	–	1	Cord, Power, 3x14, 15A
–	–	1	Idler & Stirrer Sprocket
–	–	1	Idler Support
–	–	1	Spacer
–	–	1	Spring Clamp
–	–	1	Toggle Valve, Brass, 1/4 tube X 1/4 tube

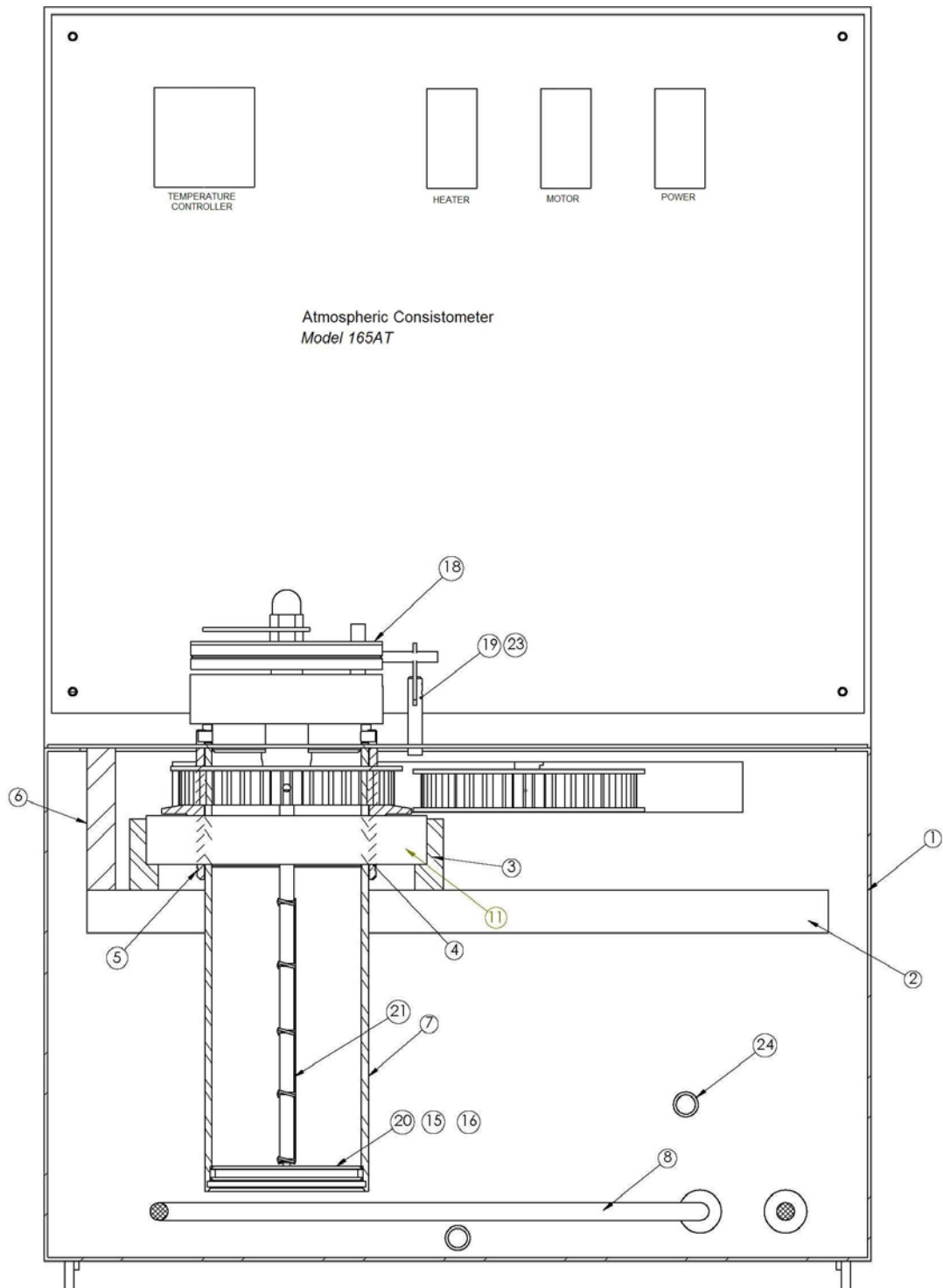

Figure 9-1 Atmospheric Consistometer, Front View

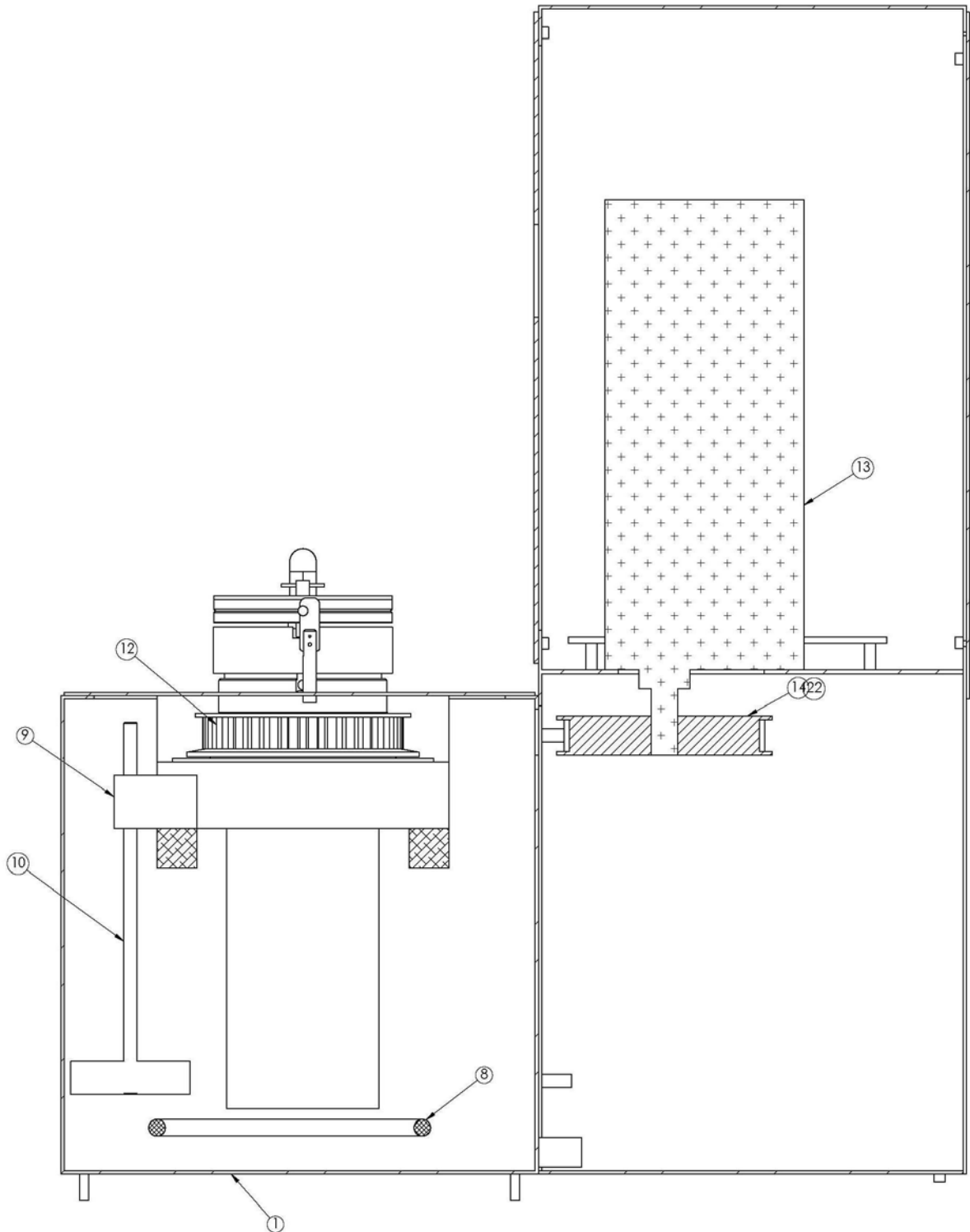

Figure 9-2 Atmospheric Consistometer, Side View

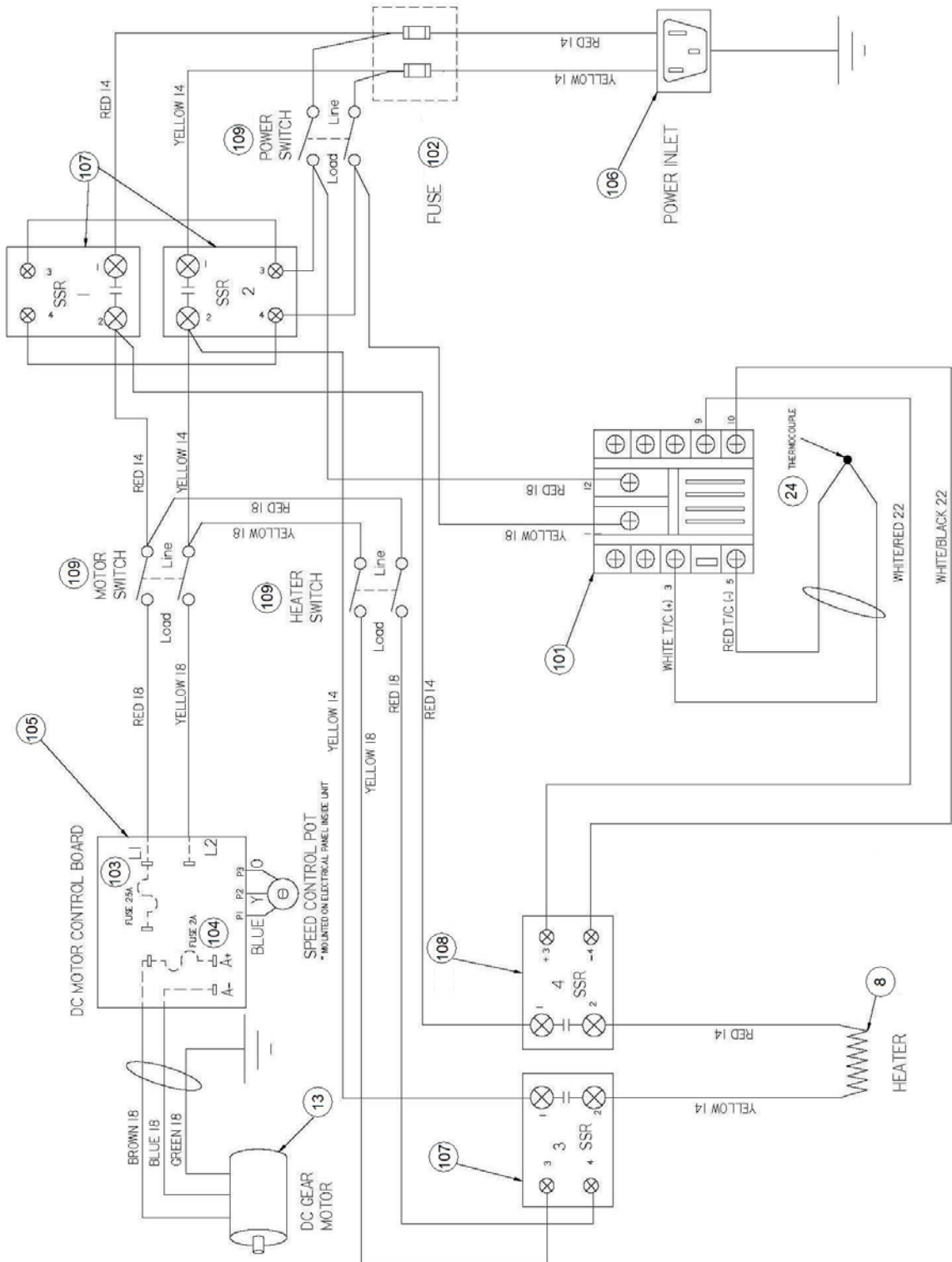

Figure 9-3 Wiring Diagram

Table 9-2 Lid Assembly, P/N 101430927

Item No.	Part No.	Quantity	Description
1	–	1	Lid
2	101597390	2	Bearing, Lid
3	–	1	Lid Shaft (non-rec)
4	–	1	Spring Collar
5	363597	1	Lid Base Assembly
6	–	1	Dial
7	–	1	Roll Pin
8	101597392	1	Lock Nut
9	–	1	Pointer
10	101597393	1	Lock Nut, Cap
11	–	1	Roll Pin
12	–	2	Roll Pin
13	–	1	Set Screw
14	101597388	1	Spring, Calibration
15	–	1	Snap Ring

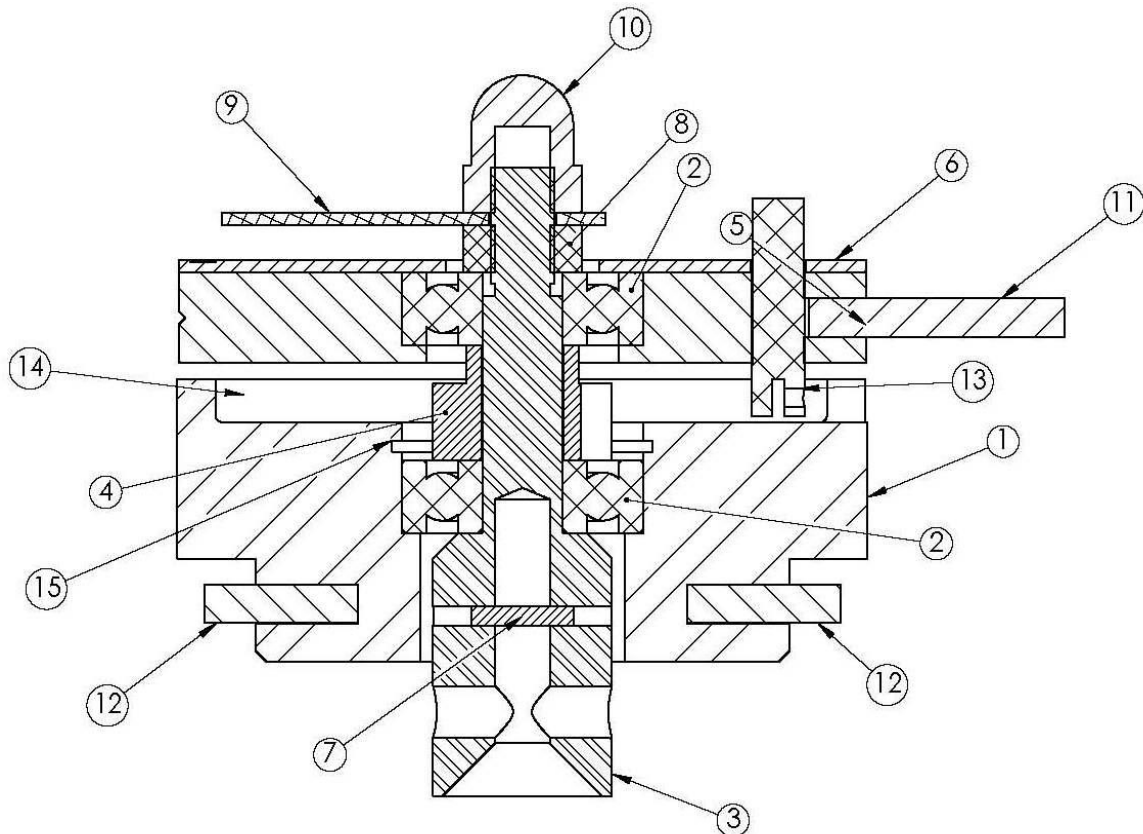

Figure 9-4 Lid Assembly

10 Warranty and Returns

10.1 Warranty

Fann Instrument Company warrants its products to be free from defects in material and workmanship for a period of 12 months from the time of shipment. If repair or adjustment is necessary, and has not been the result of abuse or misuse within the twelve-month period, please return, freight prepaid, and correction of the defect will be made without charge.

Out of warranty products will be repaired for a nominal charge.

Please refer to the accompanying warranty statement enclosed with the product.

10.2 Returns

For your protection, items being returned must be carefully packed to prevent damage in shipment and insured against possible damage or loss. Fann will not be responsible for damage resulting from careless or insufficient packing.

Before returning items for any reason, authorization must be obtained from Fann Instrument Company. When applying for authorization, please include information regarding the reason the items are to be returned.

Our correspondence address is:

Fann Instrument Company

P.O. Box 4350

Houston, Texas USA 77210

Telephone: 281-871-4482

Toll Free: 800-347-0450

FAX: 281-871-4446

Email fannmail@fann.com

Our shipping address is:

Fann Instrument Company

14851 Milner Road, Gate 5

Houston, Texas USA 77032