

Illusion® Frac Plug Helps Provide Optimum Zonal Isolation and Regains Full Casing ID Post Stimulation

OPERATOR GAINS PRODUCTION VALUE OF OVER \$51 MILLION USD

WOLFCAMP FORMATION, DELAWARE BASIN

CHALLENGES

A Permian operator needed frac stage isolation in the toe section of extended horizontal wells that would help eliminate the need for removal intervention.

- » Coiled tubing limitations in extended reach laterals
- » Eliminate the risk and cost associated with drilling out composite frac plugs
- » Increase production earnings

SOLUTIONS

Halliburton proposed using Illusion dissolvable frac plugs.

- » Operator initiated a test well - successfully utilizing 10 Illusion frac plugs

RESULTS

Illusion plugs helped provide optimum stage isolation during the frac job, and then dissolved returning the full casing ID post stimulation.

- » Operator changed their frac plug program to include an average of seven Illusion plugs in all of their lateral wells
- » Modified frac plug program - utilizing 117 Illusion plugs in the toe section of 16 wellbores
- » Gained production value of \$51 MM over a 16 well program

OVERVIEW

A Permian Basin operator drilling and completing extended horizontal wells wanted to achieve optimum stage isolation during the stimulation job to help reduce or eliminate the risk and time associated with drilling composite frac plugs from the toe section of the well using coiled tubing. Using Halliburton Illusion® dissolvable frac plugs, the operator achieved frac stage isolation, regained full casing ID after the stimulation job, and eliminated intervention. On their test well, the operator gained production value of over \$3 MM USD, by utilizing Illusion frac plugs in their toe section (1,631 ft). These positive results led the operator to continue the deployment of the Illusion frac plugs on an additional 16 wells - providing them an increased production value of over \$51MM USD.

CHALLENGE

An operator in the Permian Basin was using composite frac plugs to provide stage isolation during their stimulation job. Post stimulation, they were using coiled tubing and a drilling bottomhole assembly (BHA) to remove the composite frac plugs from the well. However, coiled tubing could not effectively reach or drill the toe section in order to remove the composite plugs. The operator noted that they could potentially lose approximately \$1,900 per foot of lost lateral in production earnings if they were not able to remove conventional composite plugs in the toe section.

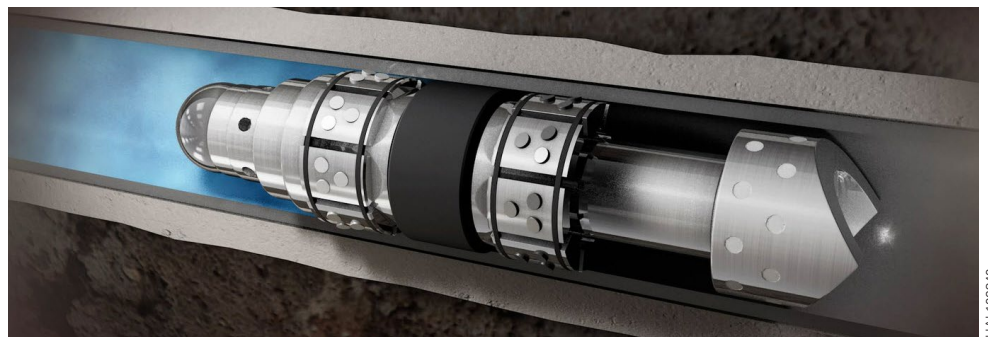

Illusion® Frac Plug helps provide optimum zonal isolation and regains full casing ID post stimulation, helping operator gain production value of over \$51 Million USD.

SOLUTION

Halliburton proposed Illusion dissolvable frac plugs as the solution to this unconventional challenge. Before deciding to embrace this solution, the operator set up a test well with 10 Illusion frac plugs and planned to trip-in the well with coiled tubing and drilling BHA post stimulation in order to test and prove the technology.

RESULT

Ten Illusion frac plugs were successfully installed with an average pump down speed of 350 ft/min and reaching a maximum speed of 450 ft/min. RapidBall™ DM self-removing balls were dropped and pumped to the frac plugs with pressure indications showing they landed and sealed on the Illusion plugs.

As promised, the operator was able to achieve greater stage isolation during the stimulation job. Fifteen days after the plugs were installed, coiled tubing was tripped in the hole with the drilling BHA and confirmed that eight of the Illusion dissolvable frac plugs had completely dissolved, and the other two were easily removed with drillout times of one to three minutes each.

With the use of the dissolvable Illusion frac plugs, the Permian operator was able to achieve optimum stage isolation during the frac job on the test well. The operator was also able to regain the full casing ID, eliminating the risk and time associated with the drillout of conventional composite frac plugs in the toe section using coiled tubing. After successful deployment and performance of the Illusion frac plugs, the operator changed the frac plug program to include Illusion frac plugs in the toe section of the next 16 extended lateral wells.

By using Halliburton dissolvable Illusion frac plugs, the operator gained a production value of over \$51 million USD from the 16 wells where the plugs were installed. A total of 117 plugs were installed covering 27,261 ft of lateral section. The successful test resulted in the operator only having to drill out the composite plugs and none of the Illusion plugs. This substantially reduced coiled tubing intervention time to drill out additional composite plugs, providing the customer with additional operational cost savings.

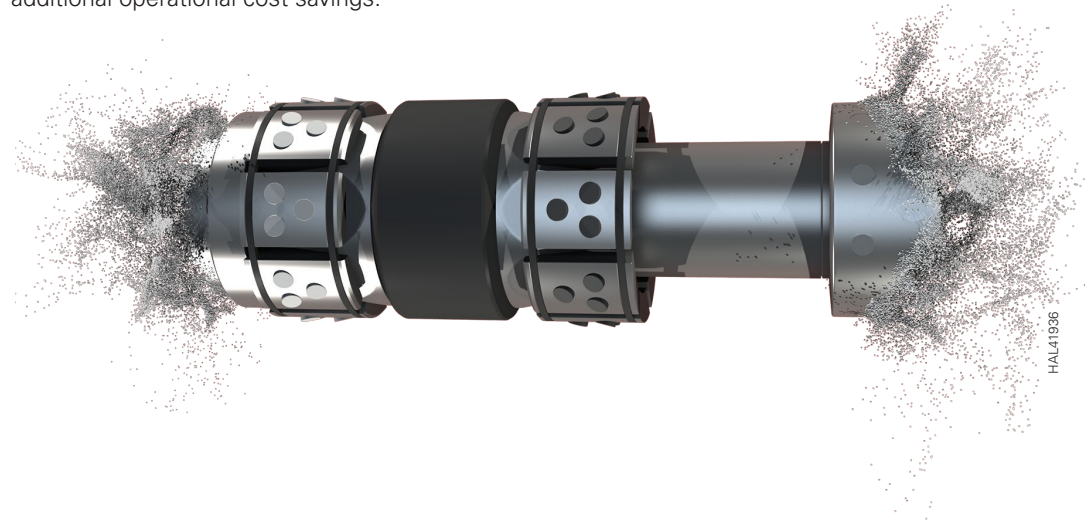

HAL41936

www.halliburton.com

Sales of Halliburton products and services will be in accord solely with the terms and conditions contained in the contract between Halliburton and the customer that is applicable to the sale.

H012519 04/17 © 2017 Halliburton. All Rights Reserved.

HALLIBURTON

**Completion
Tools**